



SOCIETÀ PER L'ELETTRONICA s.r.l.

EXPERT 2K-FA

2KW SOLID STATE FULLY AUTOMATIC LINEAR AMPLIFIER

USER'S MANUAL



Rev. 3.0

Index

IMPORTANT	4
PRECAUTIONS	4
UNPACKING	7
1. PANEL DESCRIPTION	8
1.1 Front Panel	8
1.2 Rear Panel	9
2. GENERAL INFORMATION	10
2.1 Power supply	10
2.2 Input / Output	10
2.3 ALC / RELAY / CAT	10
3. INTERCONNECTION WITH THE TRANSCEIVER	12
4. USE OF THE LINEAR AMPLIFIER	13
4.1 SO2R (Single Operator Two Radio)	14
4.2 BAND-PASS FILTERS SET "SPE BPF1"	16
4.3 QSK (FULL BREAK-IN) OPERATION	17
4.4 TUNABLE ANTENNA CONTROL	17
4.5 SETTING UP A SINGLE ANTENNA FOR RECEPTION	19
5. EXTERNAL GROUND CONNECTION	20
6. ANTENNA	21
7. POWER SUPPLY (PSU)	22
8. TUNER (ATU)	23
9. PROTECTIONS / ALARMS	25
10. PROGRAMMING	26
10.1 Ways to operate	26
11. INITIAL OPERATION OF THE AMPLIFIER	29
11.1 Initial Programming	29
11.2 Operating	31
Setting Drive Levels	31
12. CONNECTIONS	33
12.1 CAT Connector	33
12.2 ICOM	34
CAT CI-V Interface	34
12.3 KENWOOD	35
CAT RS232 Interface	35
CAT 5V TTL Interface	35
12.4 YAESU	36
CAT RS232 Interface	36
CAT 5V TTL Interface	36
BAND DATA Interface	37
12.5 TEN – TEC, FlexRadio, ELECRAFT	37
CAT RS232 Interface	37
12.6 ALC with Flex-Radio (other SDR, Elecraft)	38
12.7 TRANSCEIVERS OF OTHER BRANDS	39
13. OTHER CONNECTIONS	40
13.1 ALC, RELAY CONNECTIONS	40
13.2 REMOTE ON LINK	40
13.3 CONNECTIONS / TX-INH, TX-INH	41
13.4 AUX Connector	42
13.5 PORT Connector	43
RS232 port Remoting use	43
RS232 port Remoting use	43
14. TRANSCEIVER CONTROLLED WITH A PC	46
14.1 ICOM CI-V INTERFACE	46
14.2 RS232 INTERFACE	47
14.3 5V TTL KENWOOD INTERFACE	47
14.4 5V TTL YAESU INTERFACE	48
15. USB / RS 232 PORTS USAGE	48

15.1	REMOTE CONTROL	49
15.2	DOWNLOAD	50
16.	MAINTENANCE	50
17.	CHARACTERISTICS / SPECIFICATIONS	51
18.	DIAGNOSTICS.....	53
19.	TABLE	54
20.	APPENDIX 1 "TERM 2K SHORT GUIDE"	55
20.1	SW installation.....	55
20.2	Term_2K_USB.exe usage.....	60
20.3	Term_2K_232.exe usage	69
20.4	Firmware update	72
21.	GENERAL RESTORE	74
22.	WARRANTY TERMS	75
	REPAIR FORM.....	77

Congratulations for choosing the **SPE EXPERT 2K-FA** third series solid state linear amplifier: It is small and powerful, it covers all the amateurs bands from 1.8 to 54 MHz WARC included, completely automatically and remotable.

All operating conditions (frequency, antenna, tuner etc.) are controlled from your transceiver. The operator has only to move the frequency tuning knob on the transceiver or clicking on the spot in the cluster,

It is possible to connect it to every type of device, it is extremely user-friendly and offers a product which is best-in-class.

The main differences of this new series are:

- 1) Maximum matching possible at full power changes from 3:1 to 5:1.
- 2) Maximum output in FT8 changes from 1 KW to 1.5KW.
- 3) More efficient dissipation.

IMPORTANT

Read this instruction manual carefully before attempting to operate the linear amplifier.

The warranty will be invalidated in the case of non-observance of these instructions.

Keep this manual, it contains important safety and operating instructions for the SPE EXPERT 2K-FA.

This manual may be subject to changes and updates therefore please refer always to the updated version available on the website www.linear-amplifier.com. If in doubt, refer to the English language version.

PRECAUTIONS

Explicit definitions

WORD	DEFINITION
 WARNING!	Risk of danger of fire or electric shock to persons. Possible damage to the amplifier.
NOTE:	Serious problems if not observed. Danger of fire or electric shock for the operator, or damage to the equipment.

WARNING!

HIGH VOLTAGE! DO NOT disconnect an antenna from the amplifier during transmission; electric shock or fire is possible.

WARNING!

DO NOT modify the internal wiring of the amplifier. Any modifications will invalidate the warranty, and may reduce the performance of the linear amplifier or damage it.

WARNING!

Before using the linear amplifier, compare the value of voltage of the local mains supply network with the value required by the amplifier.

 **WARNING!**

DO NOT turn ON the linear amplifier unless it has been properly grounded through the green/yellow conductor of the mains cord. Your dealer will already have provided the correct mains plug for your local electricity network, with the earth pin connected to that conductor. Do not disconnect this under any circumstances, or there is a risk of severe or fatal electric shock.

 **WARNING!**

DO NOT use an extension cord with the AC power cable, as if it is not correctly rated there is a risk of fire or electric shock. **WARNING!**

DO NOT allow metallic objects or wires to enter inside the amplifier.

 **WARNING!**

DO NOT obstruct the entries for cooling air at both the sides of the amplifier. Ensure that no object impedes the correct operation of the fans.

 **WARNING!**

DO NOT expose the linear amplifier to rain, snow or any liquids.

 **WARNING!**

DO NOT install the linear amplifier in a place without good ventilation. This could limit heat dissipation and the amplifier could be damaged.

 **WARNING!**

DO NOT touch the amplifier with damp or wet hands. There is danger of electric shock. Avoid opening it before you have disconnected it from the mains supply, then wait at least 2 minutes for electrolytic capacitors to complete their discharge.

To clean the amplifier **DO NOT** use chemical agents like alcohol or benzene because the plastic surfaces could be damaged.

AVOID using the amplifier in areas with temperatures below -10°C ($+14^{\circ}\text{F}$) or above $+40^{\circ}\text{C}$ ($+104^{\circ}\text{F}$).

AVOID using the linear amplifier in locations that are very dusty, damp or in direct sunlight.

AVOID placing the linear amplifier against walls, the circulation of the air would be obstructed and the noise of the fans would be reflected toward the operator.

AVOID permitting children to play with the amplifier.

If you do not use the linear amplifier for long time, set the back main switch [I/O] to the OFF position [O].

Information for Users on Collection and Disposal of Old Equipment and used Batteries.



These symbols on the products, packaging, and/or accompanying documents mean that used electrical and electronic products and batteries should not be mixed with general household waste.

For proper treatment, recovery and recycling of old products and used batteries, please take them to applicable collection points, in accordance with your national legislation.

This amplifier should only be operated by persons who have an appropriate radio transmitting licence.

You should observe your license conditions while using it in accordance with national legislation.

UNPACKING

Remove the packing and carefully check the contents.

If you find any damage or if there are any parts missing, contact your retailer immediately.

Keep the shipping cartons for future transportation if required.

Accessories included in the carton

- a) Transport carry bag.
- b) 2 - cables with RCA (phono) connectors for ALC, RELAY links.
- c) USB standard cable.
- d) 3 connectors DB-15, n. 1 connector DB-9.
- e) Spare fuses: n°1 20 A, n°1 0,5 A.
- f) Air filter.
- g) Certificate of compliance and warranty form.



		Fattura n° _____ Data _____
CERTIFICATO DI GARANZIA CLIENTE Amplificatore Lineare Expert 2K-FA SIN 000000001		Merce acquistata direttamente da SPE s.r.l. <input type="checkbox"/> Merce acquistata presso rivenditore <input type="checkbox"/>
CLIENTE _____ Via _____ Località _____ C.A.P. _____ Provincia _____		RIVENDITORE _____ _____ _____
COPIA DA TRATTENERE		La garanzia verrà convalidata se spedita entro 30 giorni dalla data di acquisto (allegare copia della fattura di acquisto).

1. PANEL DESCRIPTION

1.1 Front Panel

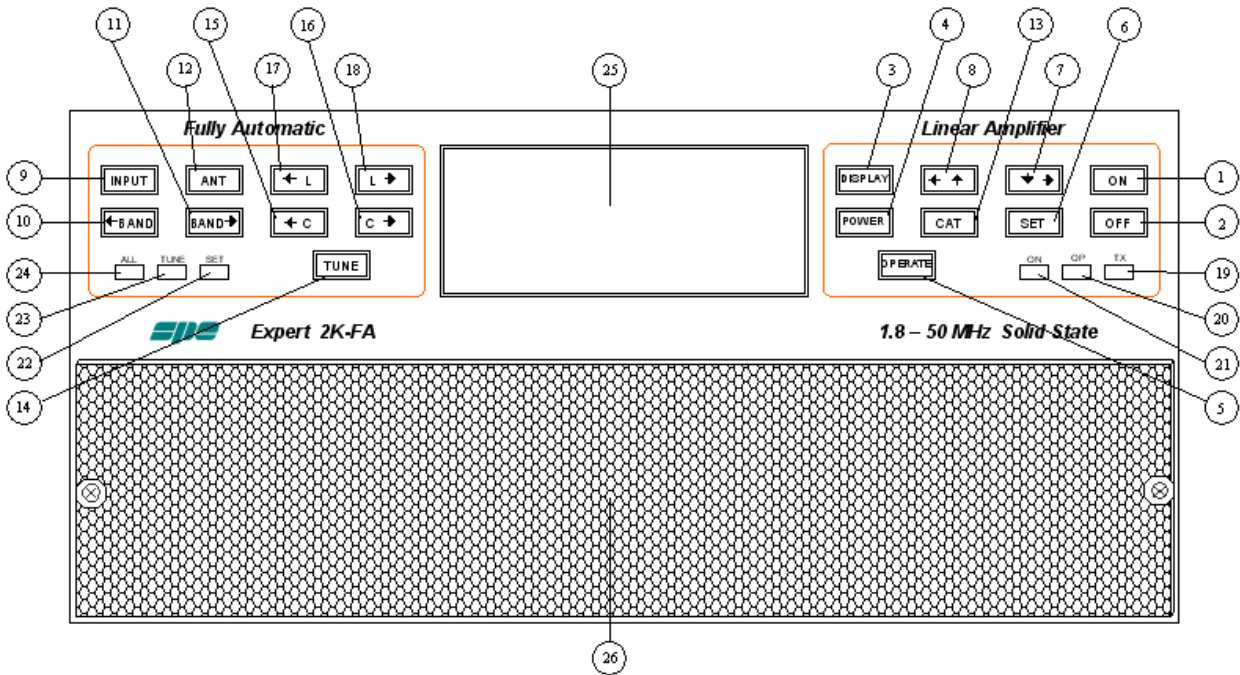

- 1) ON
- 2) OFF
- 3) DISPLAY switches between display pages.
- 4) POWER switches output power from "MAX / MID / LOW".
- 5) OPERATE switches between Standby / Operate.
- 6) SET used to program the amplifier.
- 7) ▼► used to program the amplifier.
- 8) ◀▲ used to program the amplifier.
- 9) INPUT selects one of the two inputs of the amplifier.
- 10) ◀BAND switches bands manually (downward in frequency).
- 11) BAND► switches bands manually (upward in frequency).
- 12) ANT switches the antennas for every single band
- 13) CAT shows the current CAT interface setting.
- 14) TUNE: starts the automatic tuning process.
- 15) ◀C used for manual tuning.
- 16) C► used for manual tuning.
- 17) ◀L used for manual tuning.
- 18) L► used for manual tuning.
- 19) TX red led, illuminates during transmission.
- 20) OP yellow led, illuminates when the amplifier is in "Operate" state.
- 21) ON green led, illuminates when the amplifier is "ON".
- 22) SET green led, illuminates during programming.
- 23) TUNE yellow led, illuminates during tuning.
- 24) ALL red led, illuminates when there is an alarm.
- 25) DISPLAY
- 26) AIRFLOW GRID

1.2 Rear Panel

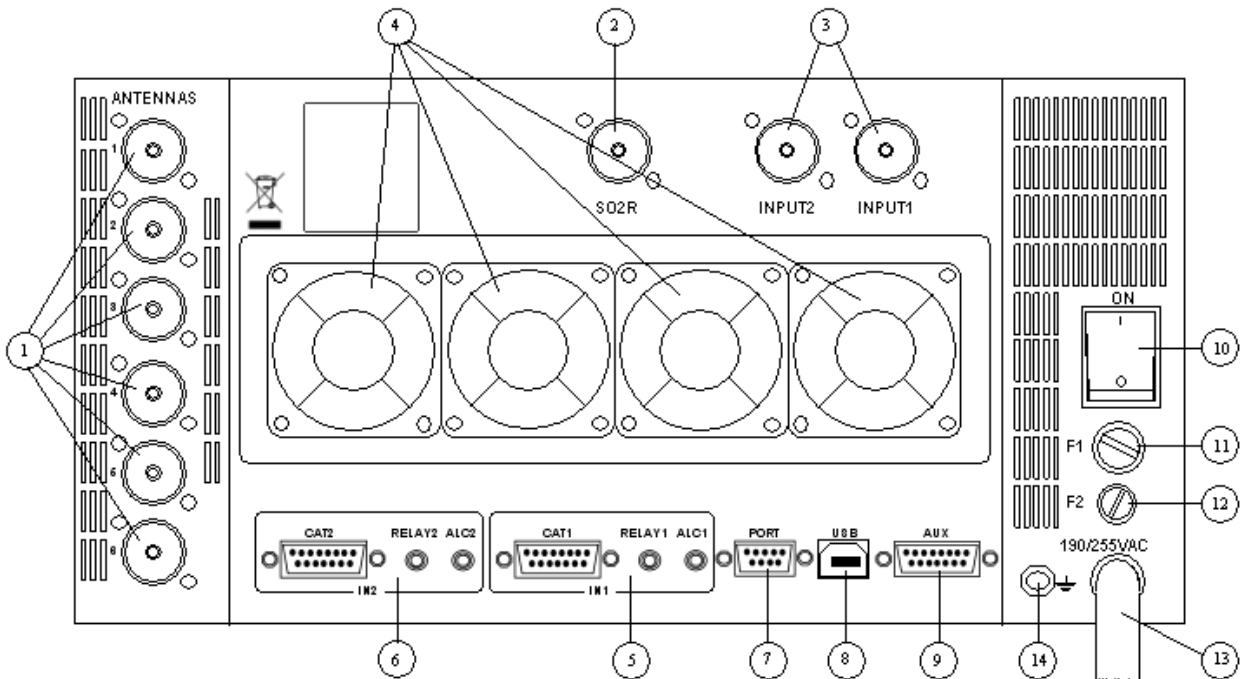

- | | |
|------------|---|
| 1) ANT | connectors for six possible antennas. |
| 2) SO2R | connector for SO2R operations |
| 3) INPUT | connectors to connect two exciters. |
| 4) FANS | |
| 5) IN 1 | ALC, RELAY, CAT connectors for exciter 1. |
| 6) IN 2 | ALC, RELAY, CAT connectors for exciter 2. |
| 7) PORT | “PORT”. |
| 8) PORT | “USB”. |
| 9) PORT | “AUX”. |
| 10) ON | main switch. |
| 11) FUSE 1 | PA unit, 20A. |
| 12) FUSE 2 | electronic unit 0,5A. |
| 13) AC | mains power cable. |
| 14) GND | ground connector. |

2. GENERAL INFORMATION

(Read the specific chapters for more details).

2.1 Power supply

The linear uses a switching power supply with a continuous input between 190 and 255 Vac.

The main switch [I/O] is located on the rear panel. In the [O] position all the internal circuitry is powered off, in the [I] position (red led ON) it is possible to turn ON or turn OFF the linear amplifier in one of the following ways:

- a) Using the [ON]/[OFF] keys on the front panel.
- b) Applying / removing 9 -15 Vdc on pin (8) of the CAT connector.
- c) Using the USB port and the management software. It is possible to download this software from the website www.linear-amplifier.com .

Note: when turned ON, almost all transceivers output 13.8 Vdc. With this voltage, the linear amplifier can be turned automatically ON / OFF at the same time as the transceiver.

2.2 Input / Output

The linear amplifier has two inputs (INPUT 1, INPUT 2) to which it is possible to connect two transceivers of any brand or type.

These inputs are selected with the [INPUT] key or automatically with the PTT of each transceiver.

It can manage up to six antennas (ANT 1, ANT 2, ANT 3, ANT 4, ANT 5, ANT 6).

The amplifier selects antennas automatically when they have been programmed.

The SO2R functionality is implemented using its own connector.

2.3 ALC / RELAY / CAT

There are two transceiver inputs (IN 1, IN 2), to allow two different transceivers to be connected at the same time.

ALC is a negative voltage generated by the amplifier.
It is used to control the output power of the transceiver (max. in STANDBY", the required in "OPERATE").
In this way the power from the exciter may be automatically *regulated*.
If the ALC port is not connected, it is necessary to manually regulate the drive power from the transceiver.
This link is highly recommended.

RELAY **This essential link** allows the amplifier to be put in the transmit state. To do that it is necessary that the inner pin of the phono connector is connected to signal ground. This is normally done at the transceiver with either a "close-on-ground" relay, or with a switching transistor. It is important that the voltages at that terminal do not exceed 12 Vdc. On the transceiver this link is often called SEND or TX GND. Refer to your transceiver manual for more details.

CAT This link is highly recommended.

Thanks to this link the linear amplifier will detect, while in receive mode, the operating frequency of the transceiver and then automatically control changes of band, antenna and automatic antenna tuner. All of modern transceivers have CAT control. In old models often, analog or digital information are sent for changing band. The SPE Expert 2K-FA, thanks to an efficient frequency counter, constantly controls and verifies data coming from the transceiver. Automatic management of bands, antennas and tuner can be done in the following way:

- a) In all recent transceivers through CAT connection (HIGHLY RECOMMENDED).
- b) In the YAESU models not listed, or without CAT, through "BAND DATA".
- c) Configurations a) and b) are recommended. In older radios which do not have CAT or BAND DATA through the internal frequency counter CAT (NONE).

Note: in case c) the CAT link with the transceiver is not needed because the frequency is detected from the transmitted signal.

FOR THIS REASON, BECAUSE OF THE HIGH POWER IN USE, IN ORDER TO NOT DAMAGE THE LINEAR, WE STRONGLY RECOMMEND YOU CHANGE BAND WITH THE LINEAR IN STANDBY MODE.

USE THE CONDITION c) ONLY IF CONDITIONS a) OR b) ARE IMPRATICABLE.

Note: in some transceivers the "RELAY" and "CAT" signals are activated by menu selection: refer in this case to their user's manuals.

3. INTERCONNECTION WITH THE TRANSCEIVER

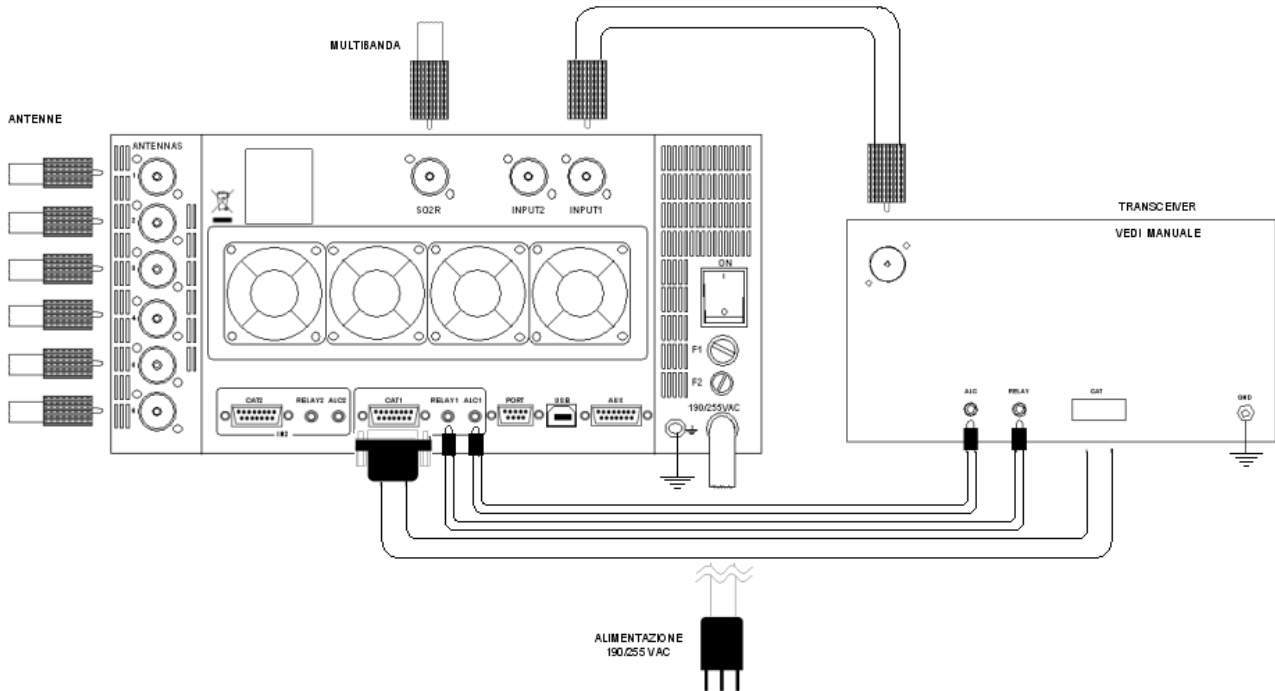

The diagram shows the connections with one transceiver only.

To connect the second transceiver repeat the same connections using the port "IN 2". For the ALC, RELAY connections, use the shielded cable (supplied) with phono RCA connectors.

For the CAT connection, the cable must be made for the transceiver to be connected. This cable may also be made to include ALC, RELAY ON / OFF (read the "CAT CONNECTIONS" chapter of this manual).

For all other information about connecting a transceiver, please refer to its manual.

4. USE OF THE LINEAR AMPLIFIER

Block diagram.

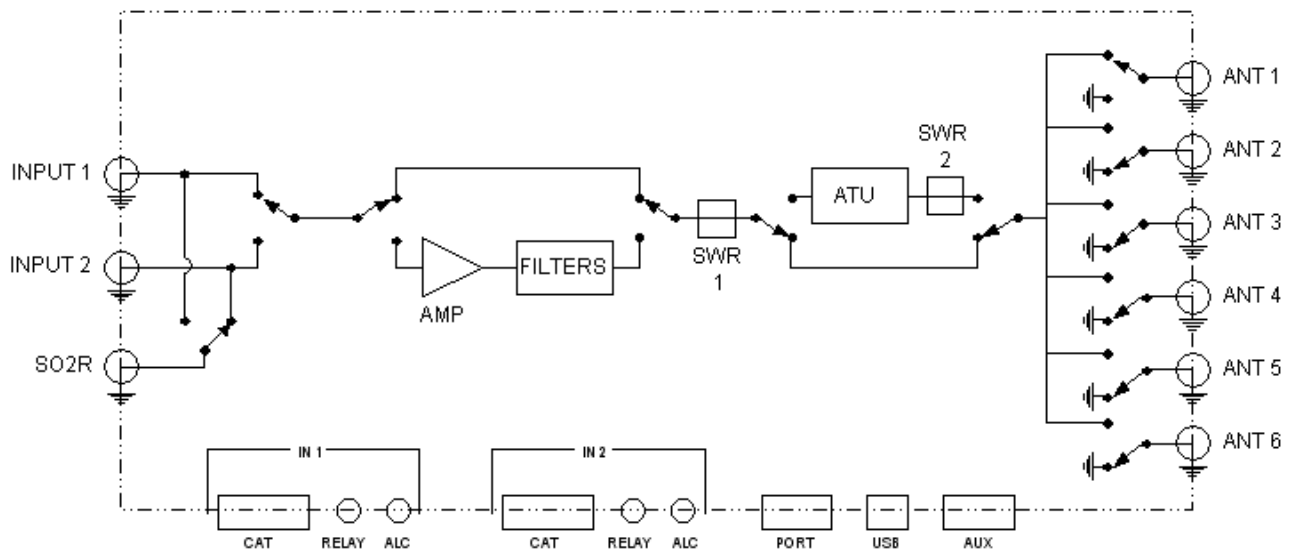

The position of the contacts, as shown in the diagram, is the situation of the linear amplifier in OFF state.

The linear amplifier can be used in the following ways:

- 1) OFF Only two direct connections are actuated:
 between INPUT 1 and ANT 1.
 between INPUT 2 and SO2R.
- 2) STANDBY All the functions are activated (band change, antenna change, tuner control) but the transmission is from the transceiver only.
- 3) OPERATE All the functions are activated and the transmission is using the linear amplifier.

*Note: regulation of the exciter's power is automatic through the ALC connection. With the ALC connected, the amplifier input power in OPERATE mode is reduced to the correct level to drive the amplifier. In standby, the exciter will give the output power as set by its POWER OUTPUT control. Without the connection, you have to manually regulate the exciter power to drive the amplifier correctly **in order to avoid damaging the amplifier.***

4.1 SO2R (Single Operator Two Radio)

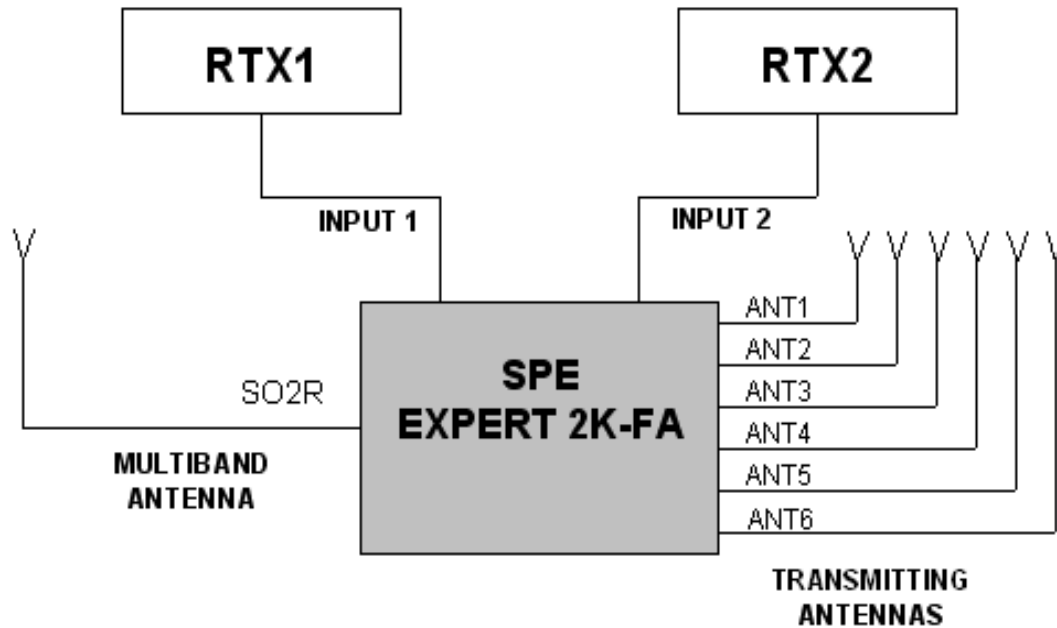

This kind of operation is used during a contest in order to acquire, as quickly as possible, a new multiplier.

The following connections are needed (see the diagram):

1. INPUT 1 connected to the first transceiver (RTX1).
2. INPUT 2 connected to the second transceiver (RTX2).
3. ANT 1/2/3/4/5/6 connected to the available antennas set.
4. SO2R connected to a multi-band antenna.

The operating mode could be the following:

If you are operating using RTX1 on a given band (e.g 20 m), the correct antenna (ANT 1/2/3/4/5/6) is automatically selected while RTX2 is connected to the multi-band antenna in RX mode on another band.

If, when operating on 20 m, a multiplier of interest is heard on RTX2 (e.g 40 m), the only action needed is to push the PTT2 in order to connect RTX2 to the 40 m antenna, while RTX1 will be switched to the multiband antenna in order to receive the 20 m band.

In place of the multiband antenna, one of the antennas ANT 1/2/3/4/5/6 can be used, in such a case all of them must be mono band to avoid the danger of using the same antenna for RTX1 and RTX2.

This possibility is offered by the use of the "AM-01 REMOTE SWITCH" external unit.

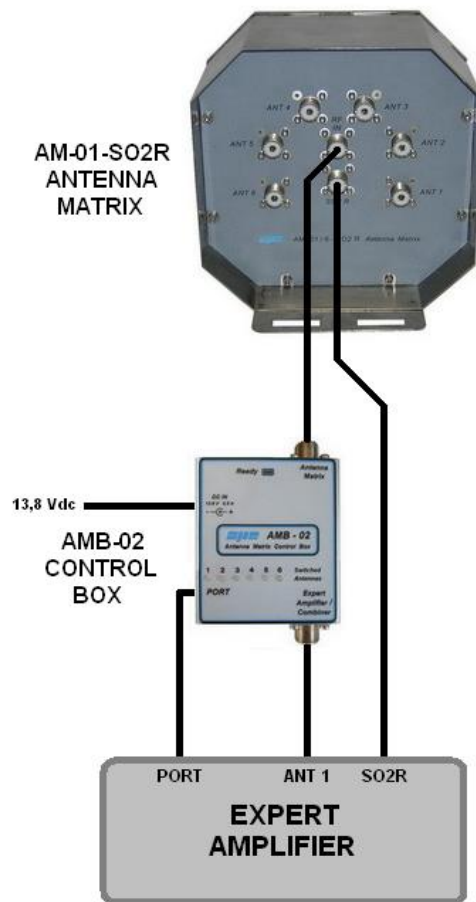

This unit is not simply a "remote antenna switch" for 6 antennas in SO2R mode, it also has the ability to become a 1 x 6 matrix, perfect for simply remoting up to 6 antennas (in this case the SO2R cable is not needed).

This solution does not require any additional cable since the antenna coaxial cable is also used to send the commands and to power the switch.

The control signals are provided by the Expert according to the table that already exists inside the linear that associates with the maximum flexibility of the antennas to the bands.

For setting, see chapter 10 "Programming" and read the AMB-01 user manual.

Note: ATTENTION, the insulation between the transmitting antenna and the receiving antenna must be high and therefore well studied.

This can be achieved by conveniently arranging the antennas and using suitable Band Filters or Stubs.

SPE is not responsible for any damage resulting from the equipment.

4.2 BAND-PASS FILTERS SET "SPE BPF1"

To increase the isolation between the transmitting and the receiving antenna SPE offers the optional unit "SPE BPF1" which must be placed between RTX1 / RTX2 and linear. The unit is controlled and powered from the AUX port. (Contact factory or your distributor for availability).

The unit automatically enables the following features:

- 1) DXpedition, Contest Multi / Multi.

In this case the amplifier is connected to a single transceiver (INPUT 1 / 2).

"SPE BPF1" automatically selects the filter on the band to be used in the input where the transceiver is connected, while the other unrelated input is unused.

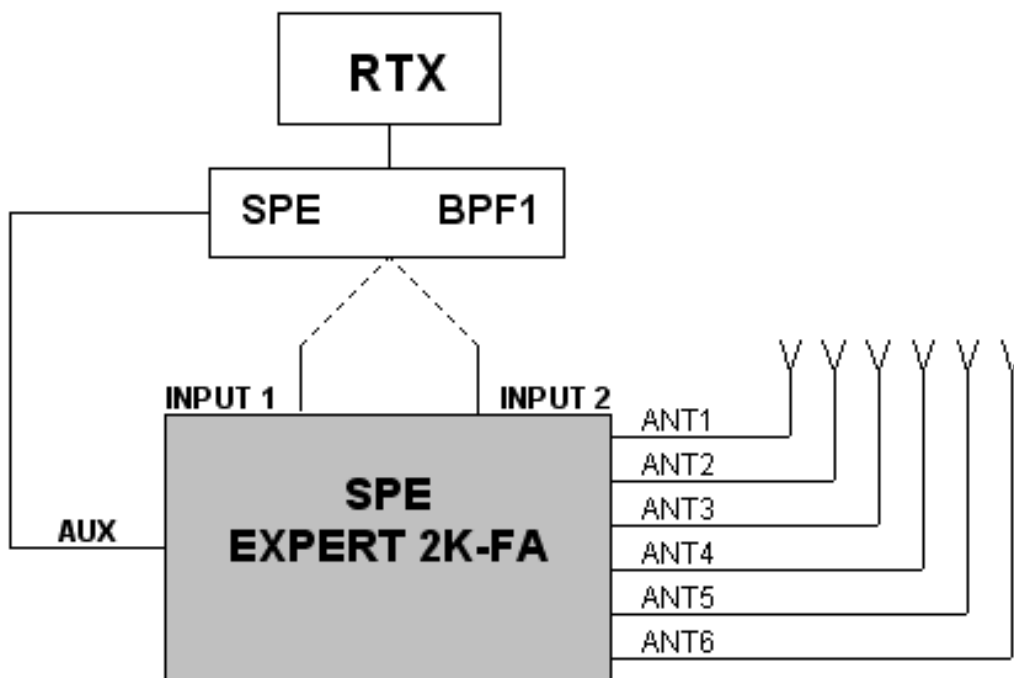

- 2) Contest SO2R.

In this case the amplifier is connected to two transceivers.

"SPE BPF1" automatically selects the right filters and the right inputs as well.

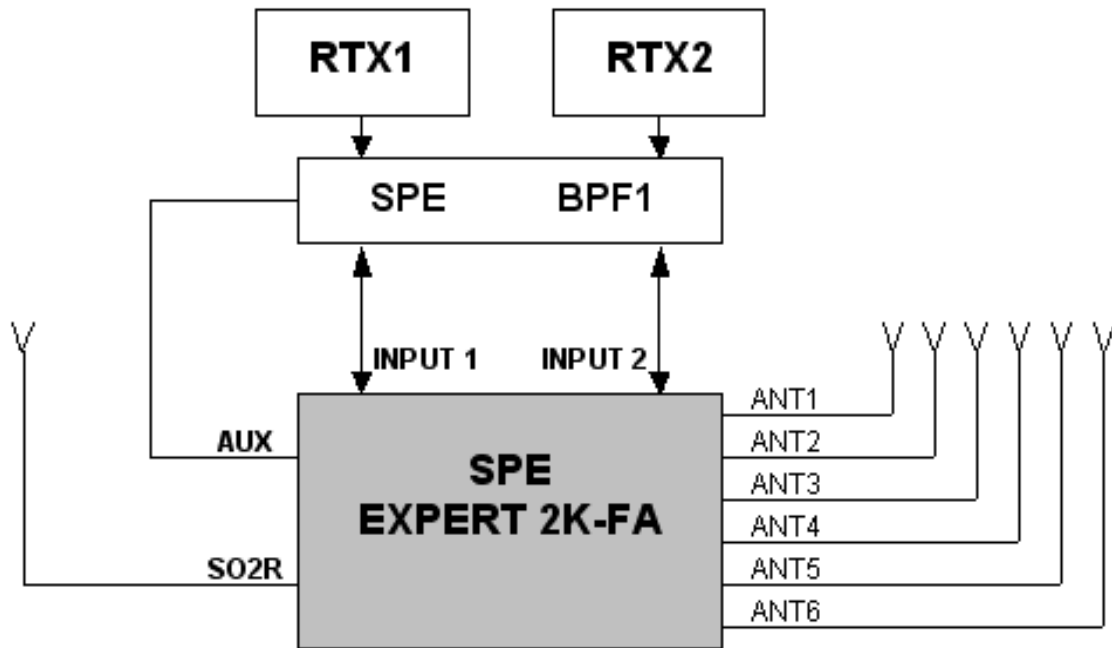

These features can be possible also with the simultaneous use of the unit "SPE SO2R1", (use the AUX port with a Y cable).

To ensure the perfect functionality of these options, the use of the CATs is recommended.

4.3 QSK (FULL BREAK-IN) OPERATION

The Expert 2K-FA allows also QSK (FULL BREAK-IN) operation. Thanks to the perfect control carried out on RX / TX switching relays, any possibility of "hot switching" is avoided.

This feature is compatible with all modern transceivers, in fact the minimum delay required before transmission is only 6.5 msec (check the manual of the transceiver).

In the case (very remote) of minor delay, you can use the link TX - INH (see "CAT" paragraph).

4.4 TUNABLE ANTENNA CONTROL

The use of tunable antennas (SteppIR, Ultrabeam) is becoming popular. These antennas vary the physical dimensions of the elements in accordance with the operating frequency to guarantee always a perfect resonance.

The Expert 2K-FA, through the dedicated connector "PORT" connected to the antenna controller, allows their automatic control following the tuning knob.

This dedicated link allows the following advantages:

- Simplification of wiring, the difficulty of adding an additional wiring to CAT input is removed.

- Compatibility with all types of CAT, the Expert 2K-FA converts the CAT protocol, so two different transceivers (CATs) can be used simultaneously with the same controller.
- Thanks to the frequency counter inside the linear, the antenna can be controlled also without the use of CAT.

All of the automatic features of the linear are retained even in the most complex configurations, antennas of all kinds can be connected to the connectors "ANT", the Expert 2K-FA will choose the antennas according to the set-up and will manage them according to their characteristics.

The CAT is recommended, if the transceiver does not have the CAT or if has only the "Band Data", the Expert 2K-FA will continue to drive the antenna with the frequency measured by the counter (data collected after the first transmission).

Up to 6 tuneable antennas can be controlled through their own controller.

The simplest configuration is a single tuneable antenna according to the following diagram:

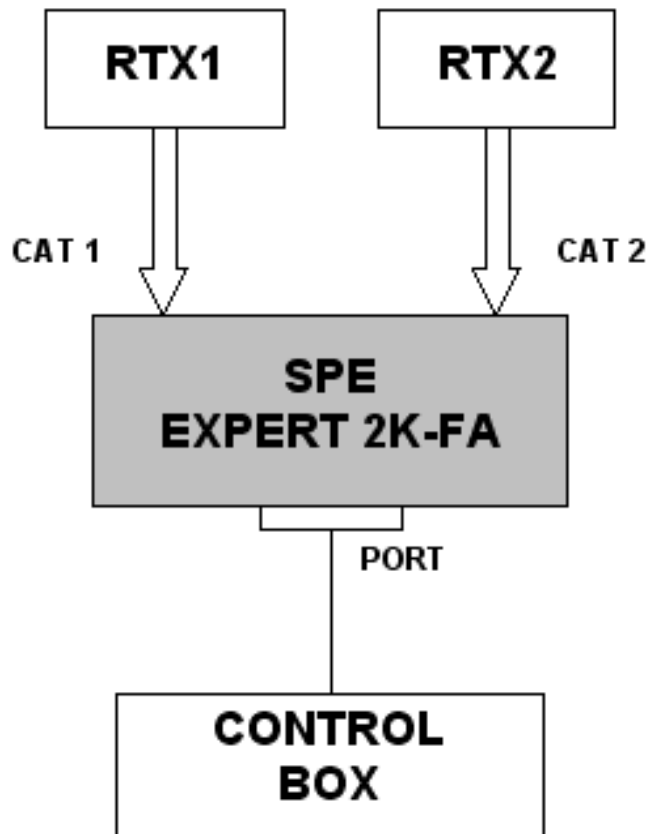

The link is unique for any position (ANT 1,2,3,4,5,6) you want use.

If you have several tuneable antennas (up to 6) and their controllers, the optional unit "SPE CBU1" is needed according to the following diagram:

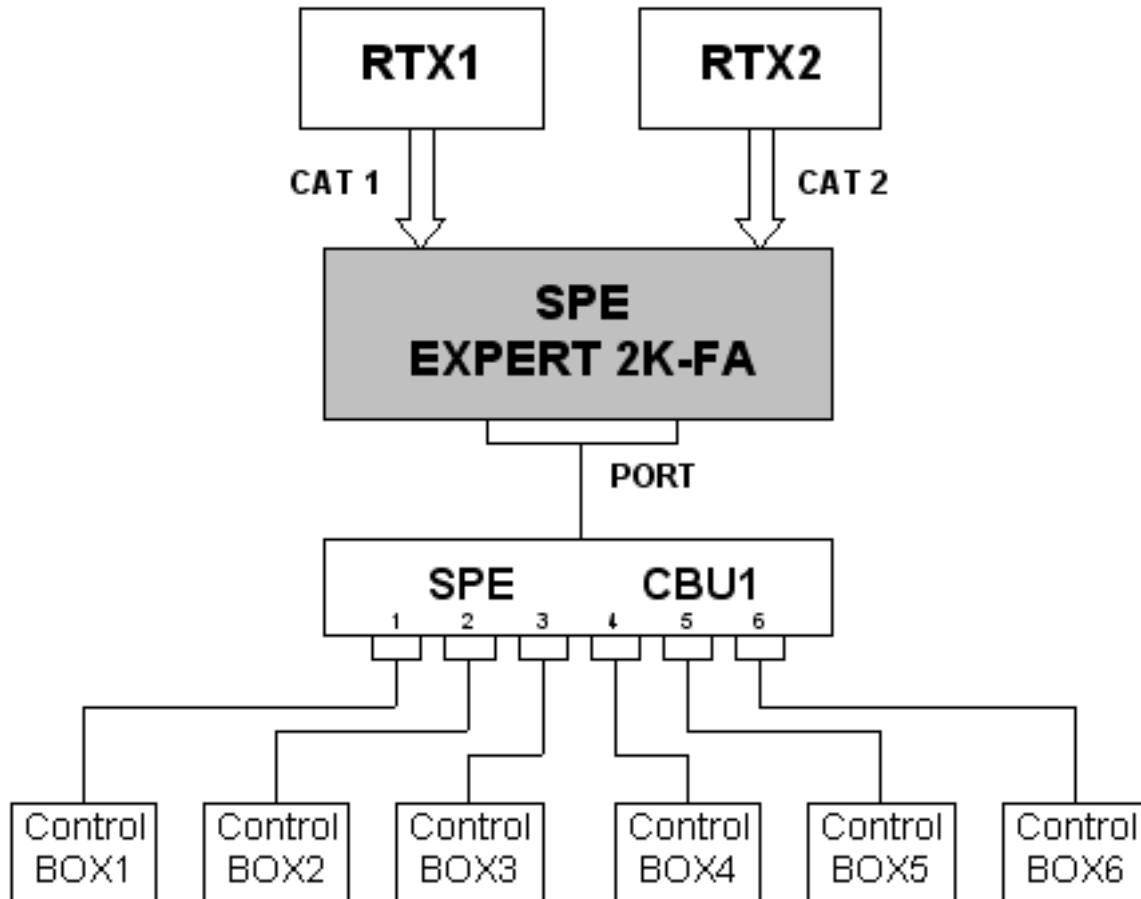

In this case you need to connect the unit control box outputs 1,2,3,4,5,6 in accordance respectively with the antennas ANT 1,2,3,4,5,6.

For the selection of antennas, refer to the "ANT TUN" in the menu.

The Protocol used is "Kenwood", the communication speed is "settable."

4.5 SETTING UP A SINGLE ANTENNA FOR RECEPTION

In some cases it may be appropriate to transmit with an antenna and receive with a more appropriate one.

A unique feature allows the Expert 2K-FA to set a receiving antenna and to provide an automatic switching after transmission.

For the selection of this antenna refer to the menu item "RX ANT".

The antenna number selected will appear close to an "r" (e. g, 3r).

Because, with linear OFF the INPUT1 is directly connected to ANT1, the selection of ANT1 is not permitted to avoid some possible danger to the transceiver if only a receiving antenna (e. g. beverage) is connected.

5. EXTERNAL GROUND CONNECTION

 **WARNING!** Before connecting an external ground as described below, check with a qualified electrician that your national wiring codes permit such a connection.

To reduce TVI, BCI and other RF problems it is sometimes helpful to connect the amplifier to a good RF ground.

The inductance of such a connection has to be low, so the connection to ground should be as short and direct as possible. Large-section copper conductors should be used for this purpose. Terminating the earth connection with a small metal plate is suggested.

The best solution is to have a ground stake, driven into the ground, and used only for the radio station.

Often good results can be achieved using correct earthing clamps, connected to the main water supply pipe (attention, most water pipes are now in plastic).

DO NOT use central heating pipework.

AVOID the electric circuit ground of the building (to be used for 50/60 Hz safety only).

 **WARNING! DO NOT** connect to gas pipes because there is danger of explosion !!

6. ANTENNA

Because this is a high-power amplifier, it is necessary to use correctly-rated antennas, connectors and feed line cables.

Take special care with antennas using baluns, traps, because balun / trap warming can occur during periods of high-power transmission and a high SWR can result.

This dangerous situation is often not perceived by the operator because normally a measure of SWR is made when balun and antenna are not under stress.

A unique feature of this linear is that, it not only measures the SWR after the matching, but also the SWR of the system antenna / cable, this allows to always evaluate your antenna system despite the matching and the power applied.

Always use antennas with SWR less than 2:1 even if the tuner is able to overcome some mismatches greater than 5:1.

With the tuner the PA is matched, but with a high VSWR, the cable is mismatched and there can be consequent loss of power, heating and high voltages present.

Always operate with the best possible matching because, despite the amplifier's protection against high SWR, continuous use into a mismatched load (a bit lower than the protection threshold) may lead to damage.

It is suggested that suitable static protection be given to antenna feeder cables.

The software allows you to select up to three antennas for the same band.

7. POWER SUPPLY (PSU)

The power supply of the SPE Expert 2K-FA, unique in its category, is switching with a PFC (Power Factor Correction) that allows a drastic reduction of the harmonic components in the mains in accordance with IEC555-2, it consists of two separate elements.

The first powers all the electronic circuits for command and control.

The second powers only the PA, its output voltages are 48 Vdc (MAX Pout), 35 VDC (MID Pout), and 30 Vdc (LOW Pout).

This design was adopted as it provides maximum efficiency and therefore less heat to dissipate.

The power supply meets the followings rules: UL60950-1, TUV EN60950-1, EN55022, EN61000-3-2,-3, EN61000-4-2,3,4,5,6,8,11; ENV50204, EN5502.

Since the amplifier is sold all over the world, the power cord does not come with any mains plug. Normally your SPE distributor will fit the plug appropriate to your domestic supply network prior to purchase. Should it be necessary to rewire the plug due to relocation in a different country, please seek advice from a qualified electrician.

To apply the plug (20 A minimum) proceed according with the following fig.

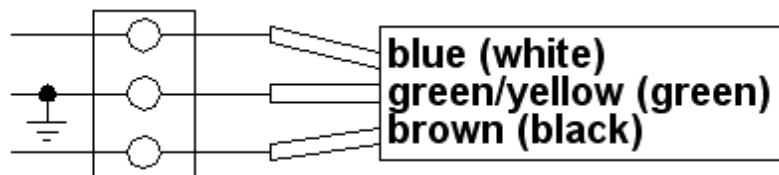

You should observe all precautions in accordance with national legislation.

The amplifier is supplied to a power supply that automatically adapts between 190 and 255 Vac, 47-63 Hz.

In case of "FATAL" alarm the power supply is blocked, to restore the linear set OFF for about 30 seconds. via the rear switch, then back ON.

In order to reduce the noise, in "Operate" the speed of the fans is increased only during the transmission time, while in "standby" they are stopped.

8. TUNER (ATU)

The amplifier has an automatic tuner that handles load mismatches up to 5:1 VSWR (2.5:1 for 6 m).

The amplifier is supplied by default with all bands in bypass, a “b” is present next to the selected antenna.

To remove the bypass go to [SET] >> “ANTENNA” and press the [TUNE] key.

To return to the bypass press the [TUNE] key again.

The amplifier contains a look-up table with all the permitted bands.

For tuner management, antenna data and other working data are stored.

Every band has a sub-band set, and for each of those, data related to the antenna and auto-ATU tuning is stored.

The CAT and the frequency counter detect the operating frequency and the correct sub-band. Thanks to the stored data, the tuner and the antenna are automatically set correctly.

For every input there is a different table. If two exciters are connected at the same time, each exciter can have different configurations.

It is possible to use the two different tables when the amplifier operates at two different locations. In fact it is possible to use the INPUT 1 at one and INPUT 2 on the other.

In this way a repeated reprogramming is not needed.

Furthermore, table driven management is useful to inhibit operation of the amplifier, for instance when an antenna for a particular band is not available.

All auto-tuner functions remain, on standby, while using the transceiver only.

Setting of the match data to write to the tables is performed automatically by pressing the [TUNE] key. The system will then find the correct match for minimum SWR.

To achieve a better match than that achieved with the automatic tune routine (most unlikely) it is possible to set the tuning manually by using the keys [◀C], [C▶], [◀L], [L▶].

When manual tuning has been performed, it is possible to read the tuning value, the working frequency and the associated sub-band on the appropriate screen page.

Both the types of tuning are always implemented in “STANDBY” state.

Before beginning the matching process, the tuner measures the SWR of the system cable / antenna. If it is greater than 5:1, the procedure does not begin and an alarm is given.

It is possible to bypass the tuner with a specific command, in order to use an external tuner.

NEVER USE THE INTERNAL TUNER WITH AN EXTERNAL ONE, it could seriously damage the linear.

IF YOU WANT USE AN EXTERNAL TUNER, BEFORE EXCLUDE THE INTERNAL ONE.

The internal tuner may be excluded:

- Totally.
- For single band.
- For single band only with a specific antenna.

It's always automatically excluded:

- With the only receiving antenna set
- With tunable antenna set.

Note: the tuner, like all analog circuits, introduces a loss (0.8 dB max.) that may vary with tuning conditions. The power meter of the amplifier does not show this loss as the power is measured at the tuner input where the load resistance is always constant (50 ohm).

*Note: ATTENTION: When the amplifier is either in “STANDBY” or “OPERATE” mode, **always** disable the automatic tuner in your transceiver.*

Note: ATTENTION: As two different tables are used for INPUT1 and INPUT2, it is necessary to program separate matching, for the same antenna, depending on the used input. Ignoring this caution could make the amplifier work for a long period with a high SWR and this practice could seriously damage the amplifier even if the protection level is a bit lower than the threshold.

9. PROTECTIONS / ALARMS

The SPE EXPERT 2K-FA has a sophisticated protection system that constantly monitors and controls the amplifier's most important parameters.

These parameters are:

Temperature of the heatsink; max. / min. voltage on the PA; max. PA current; SWR; reflected power; max voltage RF on the tuner; input power; power combiner balance.

The protection system is effected in two different ways:

- 1) Through hardware circuits to guarantee minimum intervention time.
- 2) Through software, with one of the two CPU's, to guarantee the maximum precision.

The two results are always compared, every difference produces a protection trip and consequent alarm.

There are three types of protections/alarms:

- a) **SIMPLE** This is the most common case. An acoustic warning beep sounds, but no operator intervention is required, as the control system automatically restores the correct operating conditions.
- b) **SERIOUS** When automatic system recovery is not possible (e.g. the temperature climbs over the limits due to obstruction of the fans, SWR is too high, etc.). In this case the amplifier switches into standby state and the alarm is stored. Normally transmission can continue with the exciter only.
- c) **FATAL** If the amplifier is in the b) situation but one CPU is faulty or it isn't able to operate or some fault appears in the power supply, the amplifier is turned OFF with no other warning. To restart the amplifier, the main switch in the rear panel has to be set first to [O], and then to the [I] position.

Note: it is possible to read the alarm history in the standby mode using [SET] and then [ALARMS LOG] keys, to reset the alarm file press [TUNE] and {OPERATE} keys together.

For further details, please consult the next paragraphs

Note: if the acoustic alarm is very frequent during transmission, the possible causes should be investigated.

Note: before the temperature limits are reached (76°C), the output power will change from MAX to MID automatically and then possibly from MID to LOW, so that transmission with the amplifier may continue with reduced power.

If the temperature, in LOW, is allowed to rise further, a "SERIOUS" alarm will eventually be activated and the linear switched in STBY.

Note: during a SERIOUS alarm, there is an acoustic alarm for 10 sec. Pressing the [DISPLAY] key, the system changes to 'STANDBY' state immediately.

Note: ATTENTION :when a "FATAL" alarm occurs, immediately contact your reseller.

10. PROGRAMMING

The three keys: [SET], [◀▲] and [▼▶], are underlined with an orange line and permit programming the amplifier. They can be used in the following way:

- [SET] Use it to open the menu page, to validate the choices and to exit from the menu page.
- [◀▲], [▼▶] Use these to select the options.

A green led illuminates during the programming process. Programming the system is very easy. You will find your programming choices confirmed by the items shown at the lower part of the display.

Note: programming is only possible in 'STANDBY' mode.

*Note: programming changes take effect only after exiting from the menu page (the green led turns off).
Pressing the [DISPLAY] key will come back immediately to STANDBY without any programming effect.*

10.1 Ways to operate

Pressing the [SET] key opens the menu page. On the display there are the following options:

```

_____ SETUP OPTIONS vs. INPUT 1 _____
ANTENNA          BEEP      On      TUN ANT
CAT              START    Stby    RX  ANT
MANUAL TUNE      TEMP.    °C
DISPLAY          ALARMS LOG      EXIT
_____
_____ SET ANTENNAS vs. BANDS _____
[◀▲][▼▶]:SELECT      [SET]:CONFIRM
    
```

- a) ANTENNA An appropriate antenna may be assigned to each band selecting the (ANT 1, ANT 2, ANT 3, ANT 4, ANT 5, ANT 6) connector. If you don't have an antenna for a particular band, input "N".

```

_____ SET ANTENNA vs. INPUT 1 _____
160 m: 1 2 3 | 20 m: 1 N N | 10 m: 1 N N
80 m: 1 2 N | 17 m: 1 N N | 6 m: 1 N N
40 m: 1 N N | 15 m: 1 N N |
30 m: 1 N N | 12 m: 1 N N |
                                     SAVE
_____
_____ SET 2nd ANTENNA ON 80m BAND _____
[◀▲][▼▶]:SEL [TUNE]:ATU Y/N [SET]:CHANGE
    
```

This setup allows you to preset up to 3 antennas for the same band.

The selected antennas can be switched using the [ANT] key while working either in "OPERATE" or in "STANDBY" mode.

If you want, for a certain band and for a certain antenna, bypass the tuner, just press the [TUNE] key will see a "b" next to the box.

To remove the bypass re-press [Tune].

- b) CAT Allows you to program the amplifier to accept control commands from specific transceiver types.
You may need to refer to your transceiver user manual to ensure that it is correctly programmed to handle such a link.

```

----- SET CAT INTERFACE ON INPUT 1 -----
SPE TEN-TEC
ICOM FLEX-RADIO
KENWOOD ELECRAFT
YAESU NONE EXIT
----- SET INTERFACE TYPE -----
[←][→]:SELECT [SET]:CONFIRM
    
```

Select the brand or function, for the proper link see "CAT CONNECTIONS" on this manual.

- SPE No further programming is necessary, everything is already programmed for the SPE transceivers.
- ICOM Set the "CI-V" protocol, you also need to choose the baud rate which is usually 9600.
- KENWOOD You have to choose the baud rate (almost always 9600).
- YAESU If you use the CAT connection (read the "CAT CONNECTIONS" chapter of this manual), select the model of the transceiver and then select the baud rate (almost always 4800). If the model isn't in the list, select "Band Data" (read the "CAT CONNECTIONS" chapter of this manual). For new models not listed, select FT 2000/9000 or even "Kenwood".
- TEN-TEC Make the CAT connection (read the "CAT CONNECTIONS" chapter of this manual) and follow the menu instructions.
- FLEX-RADIO Make the CAT connection (read the "CAT CONNECTIONS" chapter of this manual) and follow the menu instructions.
- ELECRAFT Make the CAT connection (read the "CAT CONNECTIONS" chapter of this manual) and follow the same indications as for KENWOOD.
- NONE Program when there isn't a link with the Transceiver. The amplifier frequency counter will then be used.

Note: if using the CAT, check that the baud rate of your transceiver is set to the same value as you program to the amplifier.

- c) **MANUAL TUNE** Allows you to tune the amplifier manually, however achieving a better setting than that obtained by automatic tuning is very unlikely.

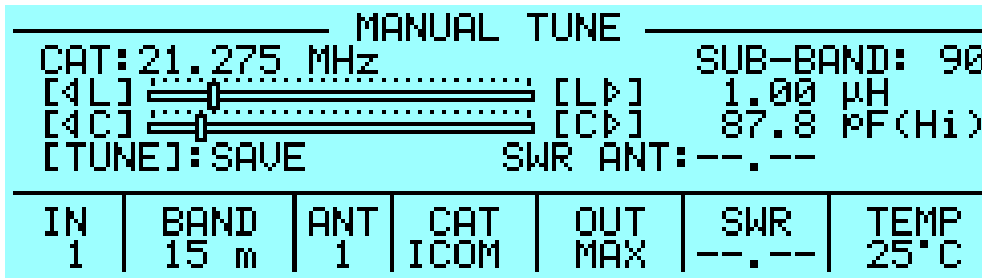

Set your exciter to transmit a continuous RTTY or CW signal. Press the [◀ L], [L ▶], [◀ C], [C ▶] keys until you obtain the minimum SWR. The operating frequency and the sub-band are also shown on the Display.

Note: the tuning process has to be repeated for every entry (INPUT1, INPUT 2).

- d) **DISPLAY** Regulates the backlight and the contrast of the display.
- e) **BEEP**
 - On : All acoustic warnings alarms operate and a beep confirms a keystroke.
 - Off : When you press a key there is no beep feedback, but for all all warning conditions and alarms, the acoustic warnings are still functional.
- f) **START**
 - Stby: Sets STANDBY mode at startup.
 - Oprt: Sets OPERATE mode at startup.
- g) **TEMP**
 - °C: Displays temperature readout expressed in Celsius degrees.
 - °F: Displays temperature readout expressed in °Fahrenheit degrees.
- h) **ALARMS LOG** Shows the most recent 10 "SERIOUS" alarms occurred.
- i) **TUN ANT** Allows you to associate a tunable antenna to one of 6 ANT connectors. A "t" highlights the selected antenna.
- j) **RX ANT** Allows you to set a single receiving antenna. An "r" highlights the selected antenna.
- k) **FAN NOISE**
 - QUIET MODE: minimizes fans noise of the PSU in Operate which then only runs during the transmission mode. Suitable if the 80ms rise time of the PSU will not damage the start of a transmission (e.g. SSB).
 - NORMAL MODE: the PSU fans, in Operate, always are running, albeit more slowly in receiving mode. The PSU is always ON so that it can't damage the first symbol of a transmission (e.g. CW, DATA).

11. INITIAL OPERATION OF THE AMPLIFIER

Before turning ON the amplifier, **read this manual with care.**

The following preliminary operations are necessary:

- 1) Read carefully this manual.
- 2) Be sure that the amplifier is correctly set for the local mains voltage supply.
- 3) Connect the amplifier to the ground circuit.
- 4) Connect the antennas.
- 5) Connect the amplifier to the transceiver (read the “CONNECTIONS WITH THE TRANSCEIVER” chapter of this manual)

Operate [I] the main switch on the back panel, and press the [ON] key on the front panel.

Select the INPUT for the transceiver, and always carry out programming with the amplifier in STANDBY. If you change INPUT you have to repeat this programming.

Note: you may have to repeat some programming if you change antenna, transceiver, etc.

Note: ATTENTION the ‘RELAY’ and ‘CAT’ signals in some types of transceivers are only turned ON from a transceiver MENU. Refer to the user manual.

Note: ATTENTION, when the amplifier is in the ‘STANDBY’ and ‘OPERATE’ modes, always disable the transceiver auto-ATU.

11.1 Initial Programming

You must carry out the next steps in the sequence below:

a) Set Antenna.

Press [SET] and open the “ANTENNA” menu page.

Assign an appropriate antenna for the band concerned. If you don't have an antenna for a band, input “N”.

When all the antennas are programmed, press [SET] to exit and go back to STANDBY.

b) Set CAT.

Press [SET] and enter the “CAT” menu page.

Select the transceiver brand and progress with programming according to the type of connection between the amplifier and the transceiver (read the “CAT CONNECTIONS” chapter of this manual).

At the end of programming, exit and go back in STANDBY.

To verify the correctness of programming, press the [CAT] key, and all the data stored will appear on the display.

To verify the correct “CAT” operation, press [SET] and select “MANUAL TUNE”, While changing your transceiver VFO, you should see the amplifier frequency display follow.

If set to "None ", transmitting briefly in RTTY or continuous key-down CW, you must read the top left transmitted frequency.

Then return to STANDBY.

In the same way, if “BAND DATA“ is connected, check that the amplifier follows band changes at the transceiver.

If it does not, verify that your programming (or your link) has been done correctly.

d) Use of Automatic Tuner

To complete the programming it is necessary to match the antennas to the amplifier by operating “TUNE“ (read the “TUNER“ chapter of this manual).

We recommend you select each band (with available antenna) and then program the tuner for the sub-bands within which you will operate.

Refer to the table in section 19 of this manual to select the appropriate sub-bands for your operating preferences.

You are strongly advised to proceed with the utmost accuracy, not just match the current frequency, but all the sub-bands you are likely to use.

Matching all the antennas on all bands available you will enjoy all the features of the automatic linear.

Proceed as follows:

- 1) Find the central frequency of the sub-band to tune in the table (refer to section 19 of this manual) and set the transceiver to that frequency.
- 2) Set your transceiver to transmit a continuous tone (RTTY or FM).
- 3) Press the [TUNE] key, then the PTT. The procedure for automatic tuning will start (you will hear the ATU relays operate) and then it will stop when SWR is at a minimum. Sometimes it is possible to improve tuning by repeating this step.
- 4) Repeat the previous steps for all bands and sub-bands you want.
- 5) Repeat the previous steps for any other antennas of the same band after having selected it using the [ANT] key.

*Note: if the ALC link is not used, it is **very important** to reduce the transceiver power to about 50 Watts during this operation.*

The initial programming concludes after steps a), b), c).

11.2 Operating

You need to exercise only a few precautions when using the amplifier thanks its high level of automation.

ALC and CAT links are highly recommended.

If ALC is not used, SPE reminds you that it is better to lose a fraction of dB in transmitted power, by slightly reducing the drive power, than to over-drive the amplifier and have a poor quality transmission.

During transmission check the parameters on the display always, because SPE has selected, designed and adjusted them with care.

SPE recommends (when using the ALC link) that the transceiver should be set to its maximum output power, the ALC will reduce the driving power to the optimum driving level.

To reduce the linear output, if required, it is then necessary only to set the amplifier to "MID" or "LOW" with the [POWER] key.

Of course you may also regulate continuously the amplifier output power by changing the level of drive power from your transceiver (also with the ALC connected).

If less output power than 2KW, 1KW or 500 Watts is desired, it is preferable, for best efficiency, to start to reduce drive from "MAX", "MID" or "LOW" power state.

Setting Drive Levels

- a) SSB: Regulate the "MIC GAIN" of the transceiver until, speaking normally into the microphone, the signal peaks on the display don't quite reach the maximum rated output power. Monitoring the transmission is a good way of checking your settings. If there is however some distortion, decrease the "mic gain" or decrease the power of the transceiver until a small reduction of the output power of the amplifier is seen.
- b) CW: In key down, you get the maximum output power automatically.
- c) RTTY, Digital modes, SSTV, FM: Because all of these types of transmissions have a very heavy duty cycle, you should not operate in 'MAX' but only in "MID" and "LOW".
An appropriate SW ensures this requirement.
- d) AM: This transmission mode radiates a continuous carrier which is 25% of its PEP value (e.g. 400W PEP AM = 100W carrier power). SPE recommends you always operate in 'MID' or "LOW" mode for AM.
To get an output signal without distortion, proceed as follows:
transmit the AM carrier only, with your transceiver "MIC GAIN" set to zero, set the transceiver without exceeding 25% of the maximum carrier output from the amplifier.
Then, speaking into the microphone normally, set the "MIC GAIN" of the transceiver until the peak output power, on speech peaks, as shown on the amplifier display, is no more than 1 KW or 500W. SPE suggests you monitor your transmission to check that the "MIC GAIN" setting is correct.

- Note if you choose to set the output power of the amplifier by varying the output power of the transceiver, the ALC connection is not strictly required.
In this case **you** must be careful not to overdrive the amplifier to avoid distortion and broadening of the channel (with the ALC, adjustment is automatic for maximum linearity and Pout).
All functionalities remain the same protections included, the only feature that is less is the return to full power to the transceiver when it returns to STANDBY.*
- Note: ATTENTION, never stress the amplifier with long periods in key-down transmission, as this can stress the amplifier components. An appropriate SW avoids transmitting a continuous signal in the "MAX" condition for a long time by switching to "MID".*
- Note: in SSB use a compressor only when necessary; this strongly reduces the temperature increase.*

12. CONNECTIONS

12.1 CAT Connector

In this diagram the rear panel CAT connector and pin-outs are shown. If you have already used our 1K-FA amplifier you will note the connections are the same.

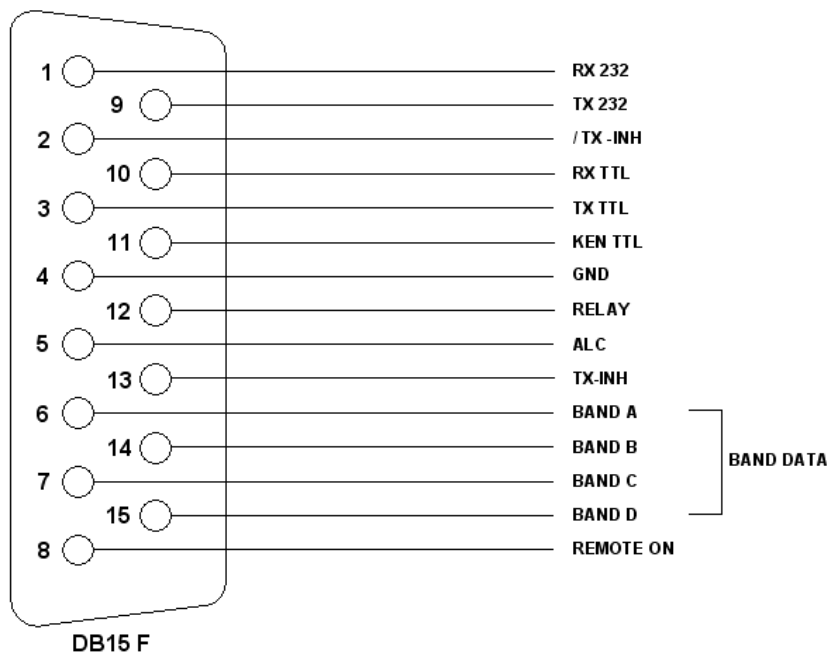

pin n.	pin name	Description
1	RX 232	Used on KENWOOD and YAESU transceivers for the link with a RS-232 connection.
9	TX 232	Used on Icom, KENWOOD and YAESU transceivers for the CAT 5V connection.
2	/ TX - INH	Open collector normally off, stops transmission when gnd (on).
10	RX TTL	Used on Icom, KENWOOD and YAESU transceivers for the CAT 5V TTL connection.
3	TX TTL	Used on Icom, KENWOOD and YAESU transceivers for the CAT 5V TTL connection.
11	KEN TTL	Connect to GND if CAT 5V TTL KENWOOD connection.
4	GND	Signal ground.
12	RELAY	Connected in parallel with the RCA phono RELAY connector.
5	ALC	Connected in parallel with the RCA phono ALC connector.
13	TX - INH	Normally to gnd (550 ohm), stops transmission when + 12V.
6	DATA A	Bit A of Band Data (digital switch of band for YAESU).
14	DATA B	Bit B of Band Data (digital switch of band for YAESU).
7	DATA C	Bit C of Band Data (digital switch of band for YAESU).
15	DATA D	Bit D of Band Data (digital switch of band for YAESU).
8	REMOTE ON	Applying a voltage from 9 to 15 Vdc, turns the amplifier ON.

Using the above information, an appropriate cable for your transceiver(s) may be constructed, or you might wish to order a correctly made-up cable when you order your amplifier from your local dealer. The amplifier connector is included with the amplifier, and the transceiver connector (called "Radio" in the next diagram) is usually supplied with the transceiver.

For connections to the Radio connector, refer to the transceiver operating manual.

12.2 ICOM

CAT CI-V Interface

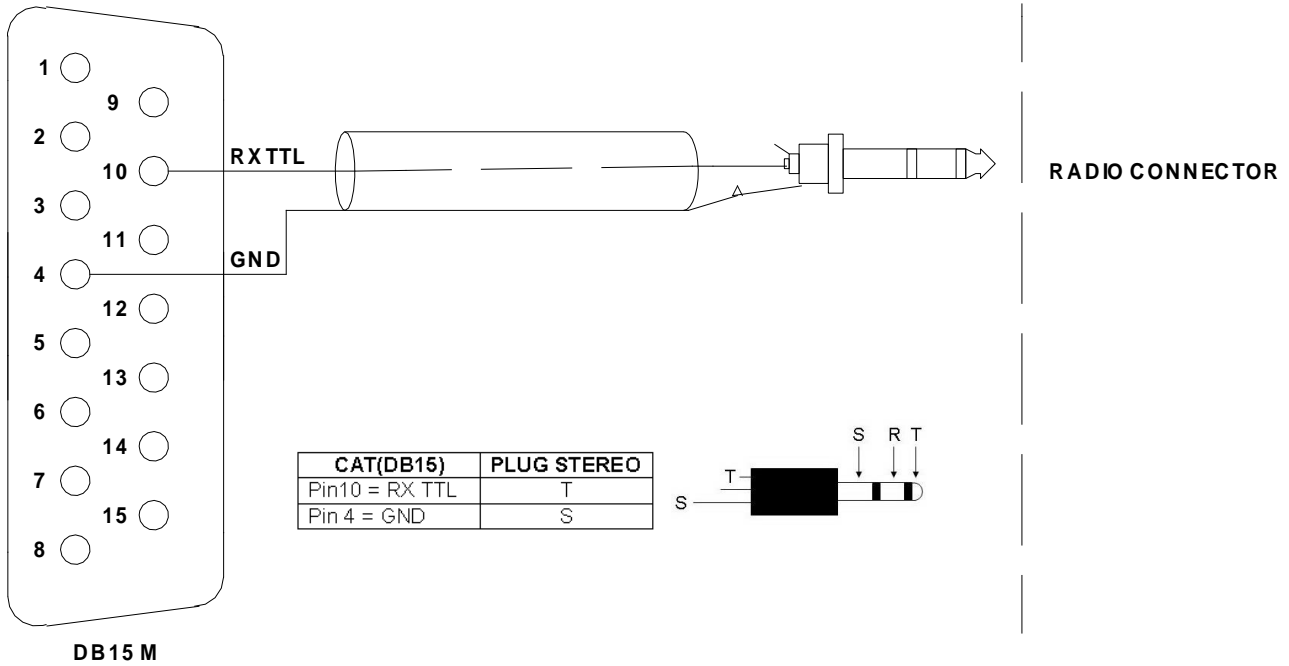

This interface is standard for all the Icom models equipped with CAT. The cable always terminates to a 3.5 mm. mono plug.

It is possible to use a stereo plug according to the figure above.

In the transceiver menu:

Set "CI-V Output (for ANT) ON" (if present).

Set "CI-V Transceive ON" (in the absence of the previous one).

With one of the previous settings the transceiver transfers the frequency at each tuning variation or in the presence of external software that cyclically interrogates the transceiver (e.g. LOG in a PC), see chapter 14.

12.3 KENWOOD

CAT RS232 Interface

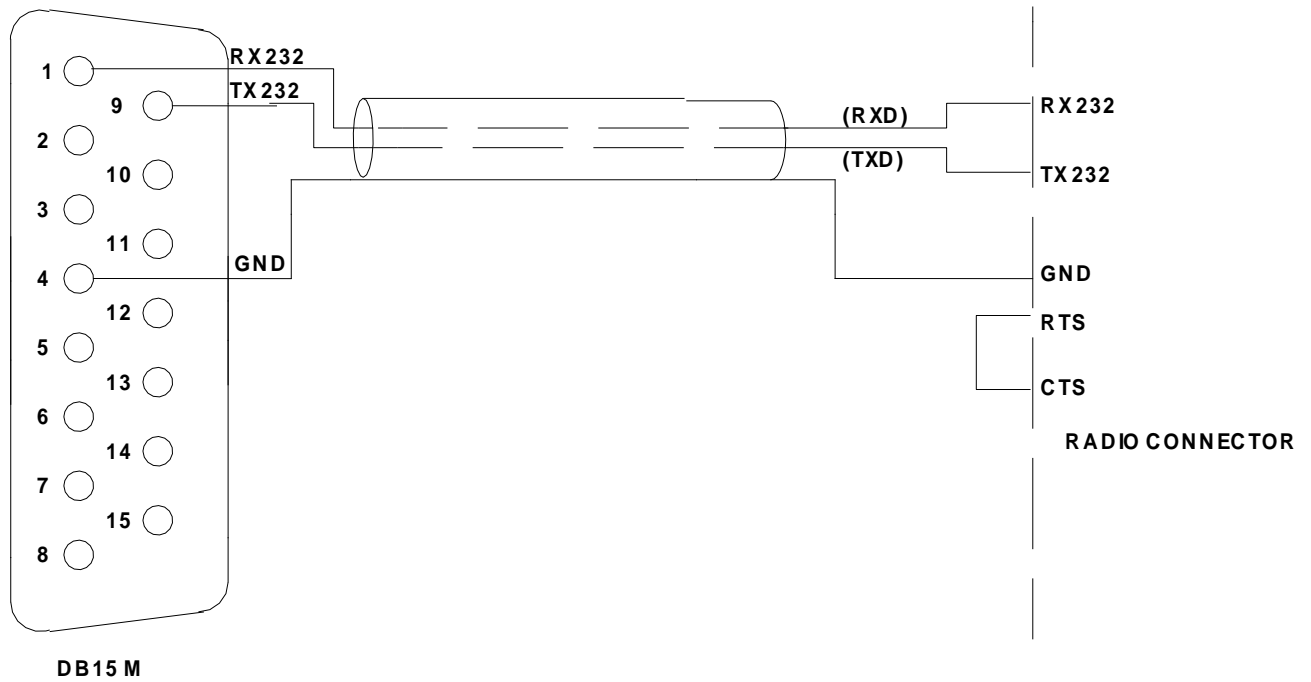

The Radio connector could be DB-9 or DB-25 male connector or female connector (read the specific manual). In the manual, also verify if the RTS–CTS link is necessary.

CAT 5V TTL Interface

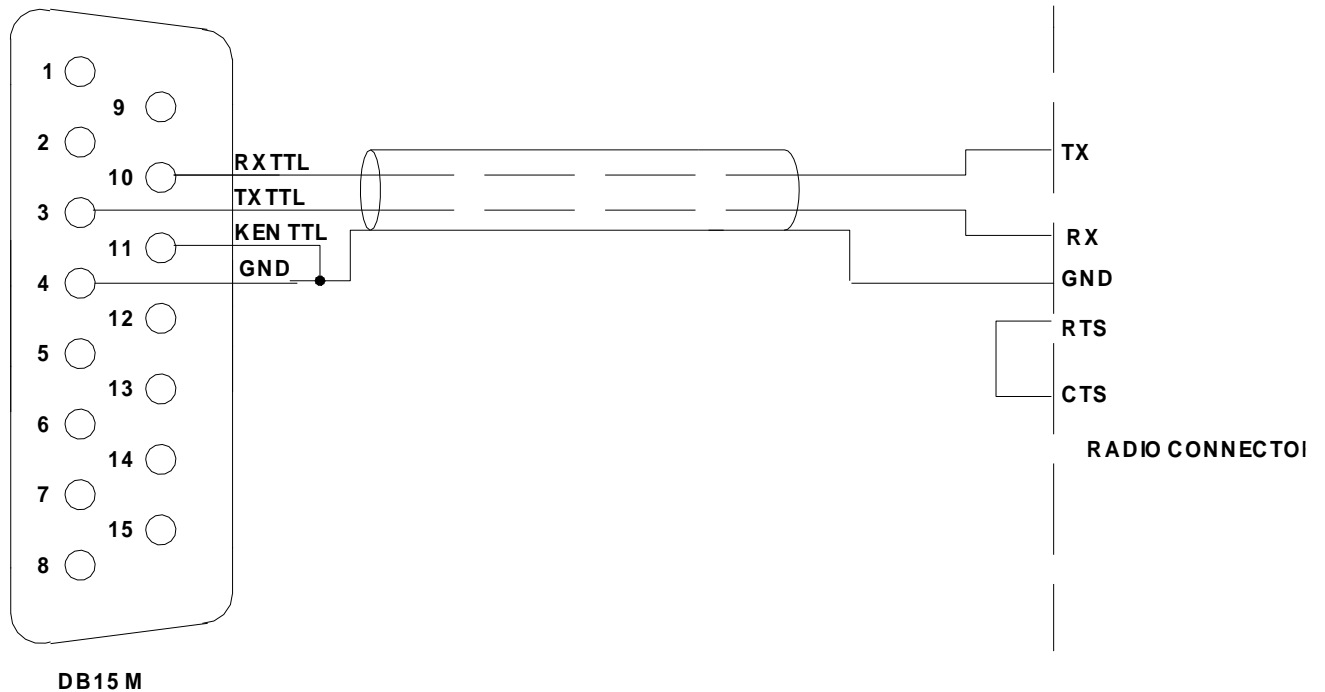

The connector is described in the specific manual. Verify if the RTS–CTS link is necessary.

12.4 YAESU

CAT RS232 Interface

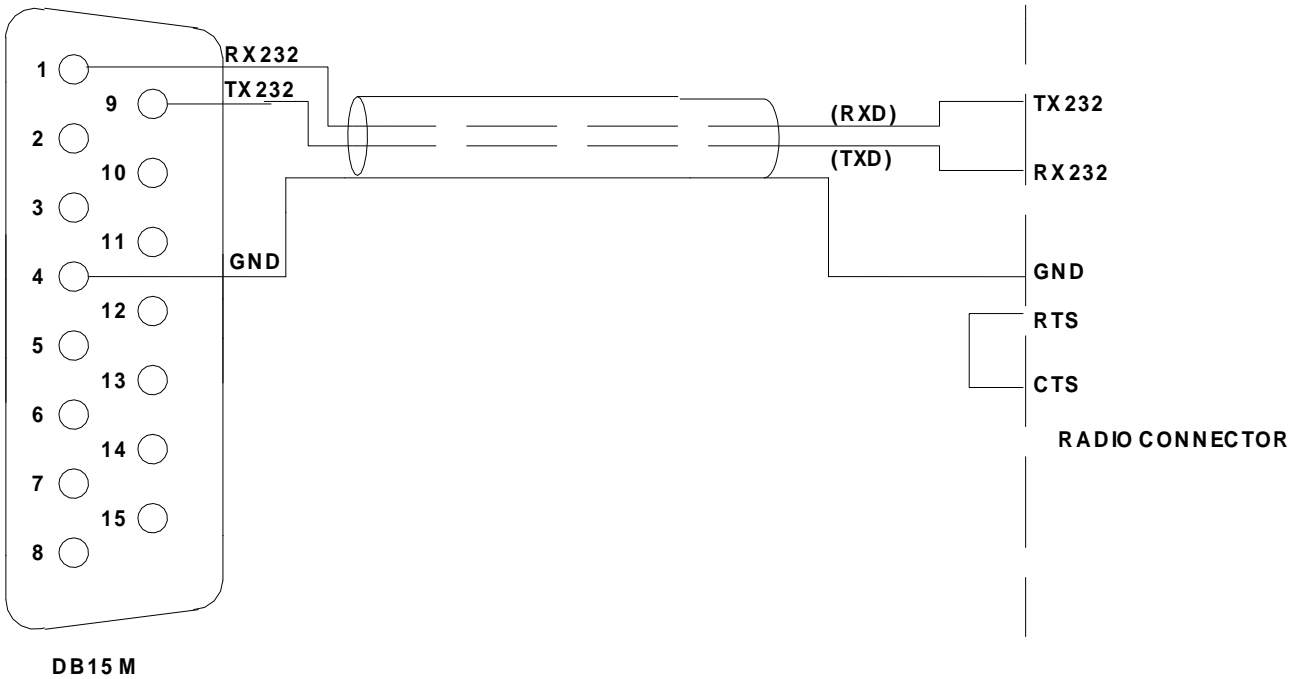

The radio connector may be a DB-9 or DB-25 male connector or female connector (read the specific manual). Verify from the manual if the RTS–CTS link is necessary.

CAT 5V TTL Interface

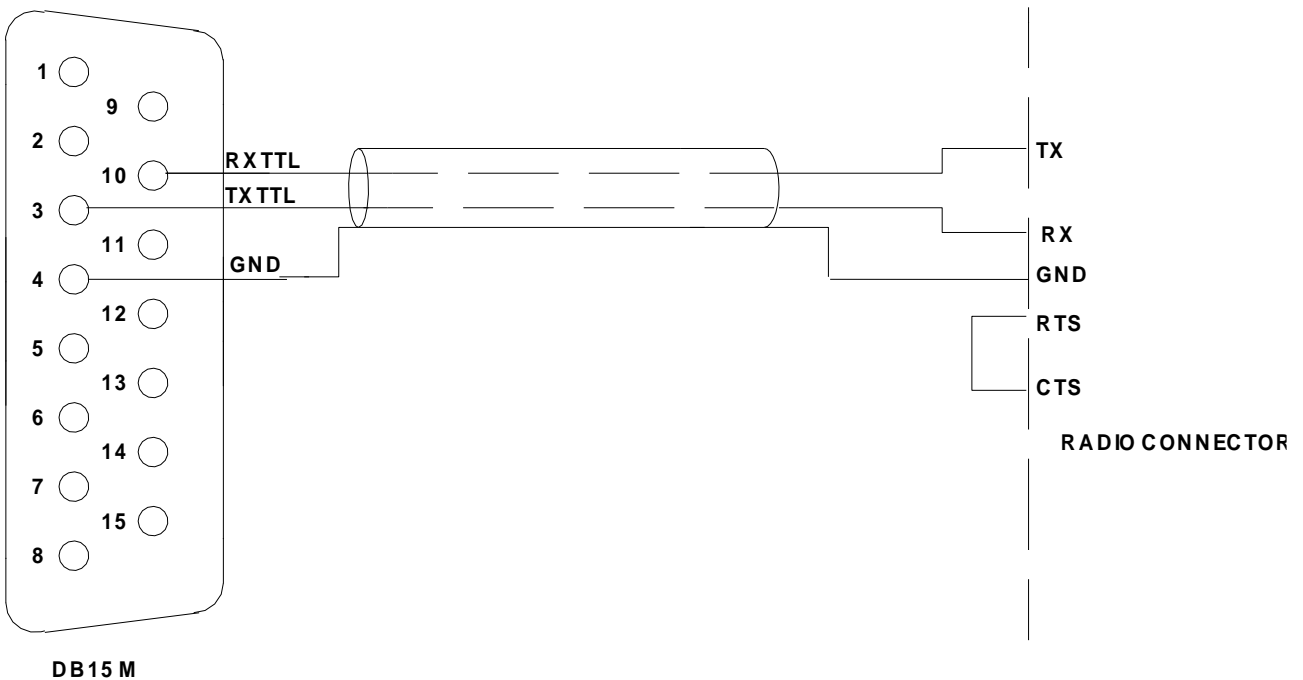

The connector is described in the manual. Verify if the RTS–CTS link is necessary.

BAND DATA Interface

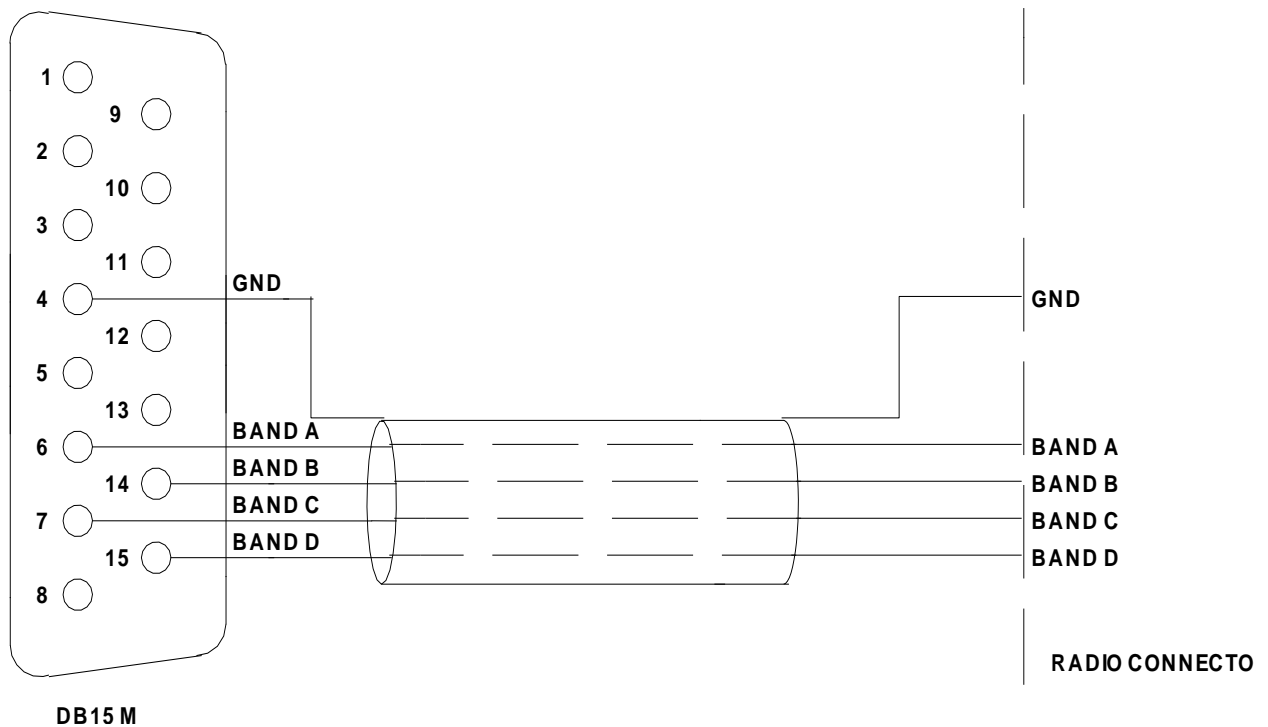

Without the CAT, the band is commanded by four digital signals (Band A, Band B, Band C, Band D). Refer to the specific manual.

12.5 TEN – TEC, FlexRadio, ELECRAFT

CAT RS232 Interface

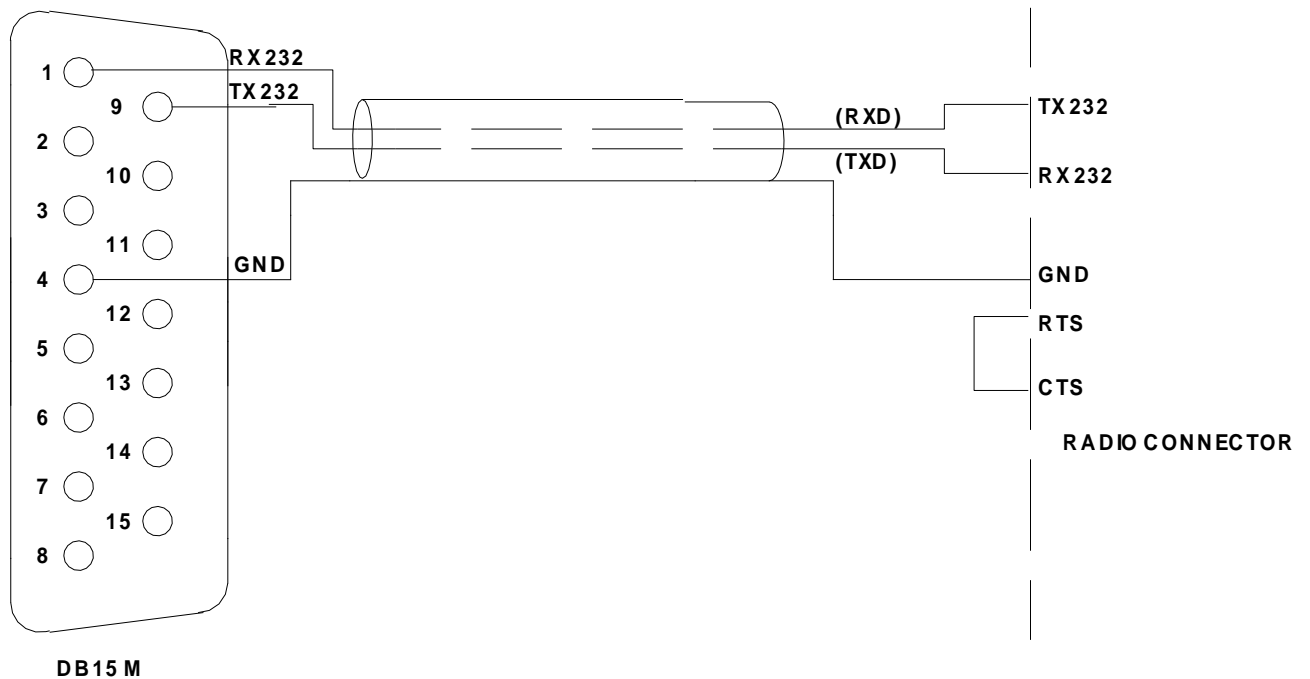

The radio connector may be a DB-9 or DB-25 male connector or female connector (read specific manual). Verify from the manual if the RTS–CTS link is necessary.

12.6 ALC with Flex-Radio (other SDR, Elecraft)

Since Flex-Radio transceivers, like any SDR equipment, do not have the necessary input to receive the analog ALC signal from the amplifier, it is possible to manually preset the transceiver output power at MAX, MID and LOW levels in order to avoid the danger of over-driving the Expert.:

For every ham band three settings are allowed (storage memories):

- One setting for MAX mode.
- One setting for MID mode.
- One setting for LOW mode.

The following table shows an overall vision of these settings:

Band	160 m	80 m	60 m	40 m	30 m	20 m	17 m	15 m	12 m	10 m	6 m
MAX	Preset Max	Preset Max	Preset Max	Preset Max	Preset Max	Preset Max	Preset Max	Preset Max	Preset Max	Preset Max	Preset Max
MID	Preset Mid	Preset Mid	Preset Mid	Preset Mid	Preset Mid	Preset Mid	Preset Mid	Preset Mid	Preset Mid	Preset Mid	Preset Mid
LOW	Preset Low	Preset Low	Preset Low	Preset Low	Preset Low	Preset Low	Preset Low	Preset Low	Preset Low	Preset Low	Preset Low

To set the memories proceed as follows:

- 1) Connect the CAT of the amplifier with the CAT of the Flex-Radio with the appropriate cable (consult the respective manuals), then select the "FLEX - RADIO CAT in the Expert menu.
- 2) Switch to "OPERATE".
- 3) Set the transceiver in the band of interest using the CAT.
- 4) Select LOW.
- 5) Without going into transmission, press one of the two arrow keys ([◀▲] [▼▶])
On the EXPERT keyboard, an indication will appear on the Status Bar (above the BAND label) with the following format "[PC=xxx]" where xxx is a numerical value ranging from 000 to 100 which represents the Pout level (expressed as a percentage) of the transceiver relative to the set band at LOW mode.
- 6) Using the arrow keys ([◀▲] [▼▶]) you can decrease / increase the value presented to reach the desired Pout level.
It is advisable to initially start from low values (e.g. 005) and then gradually increase, this is to avoid overdriving the linear.
At the end of the setting you must wait (about 3 seconds) for the "[PC:xxx]" indication to disappear.
- 7) Then go to transmit (RTTY, CW) to check the output power obtained.
If you have not reached the desired Pout, return to point 6 until you reach the rated level or lower (don't overdo it, you risk putting the amplifier into compression).
- 8) Select MID and repeat steps 6 and 7.
- 9) Select MAX and repeat steps 6 and 7.
- 10) Repeat steps 3, 4, 6, 7, 8, and 9 for each available band.

End of programming.

The following picture shows (as an example) the **Power Control** of the **15 m** band in **MAX** power mode:

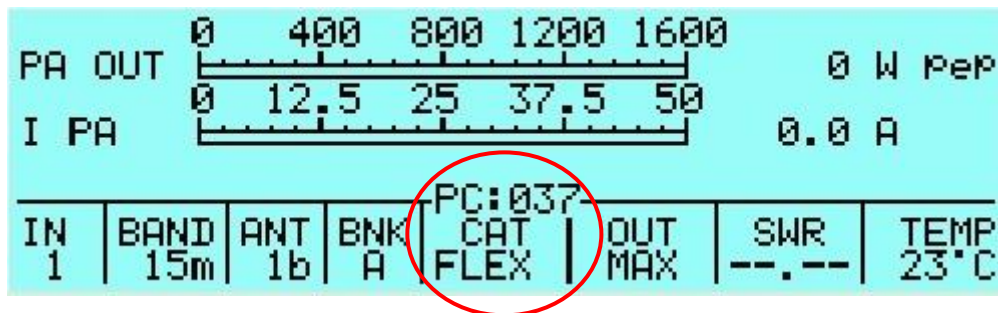

The following empty table is suggested as a template for the Flex Radio user's Power Control adjustments.

Band	160 m	80 m	60 m	40 m	30 m	20 m	17 m	15 m	12 m	10 m	6 m
MAX											
MID											
LOW											

N.B. This procedure has been studied and verified for FLEX transceivers, it should also be valid for all SDRs with Kenwood protocol (check).

Even if the Elecraft transceivers have an ALC input this is not compatible, as they use a Kenwood protocol, to control the Pout of the amplifier it is possible to use the procedure described for the FLEX setting the CAT FLEX-RADIO.

Attention: it is recommended not to exceed the Pout setting, respecting the following levels: LOW (500 W), MID (1000W), MAX (1500W).

The settings must be redone if you change transceiver.

The procedure is valid for both memory banks.

12.7 TRANSCEIVERS OF OTHER BRANDS

A special link is not necessary as the internal amplifier frequency counter will measure the input frequency and will control the amplifier.

Note: WARNING, SPE is not responsible for any failure resulting from misuse of HW interface.

13. OTHER CONNECTIONS

On the connector, in addition to the CAT signals, the ALC and RELAY signals are repeated, REMOTE ON, /TX-INH, TX-INH are also available. If you use this connector to connect the ALC and RELAY lines, separate phono cables are not necessary, or it may be possible to turn the amplifier on / off by turning on / off the transceiver (REMOTE ON).

The following diagram shows how to integrate all transceiver control connections to the DB15 amplifier connector.

Check the transceiver manual for terminating that end of the cable.

13.1 ALC, RELAY CONNECTIONS

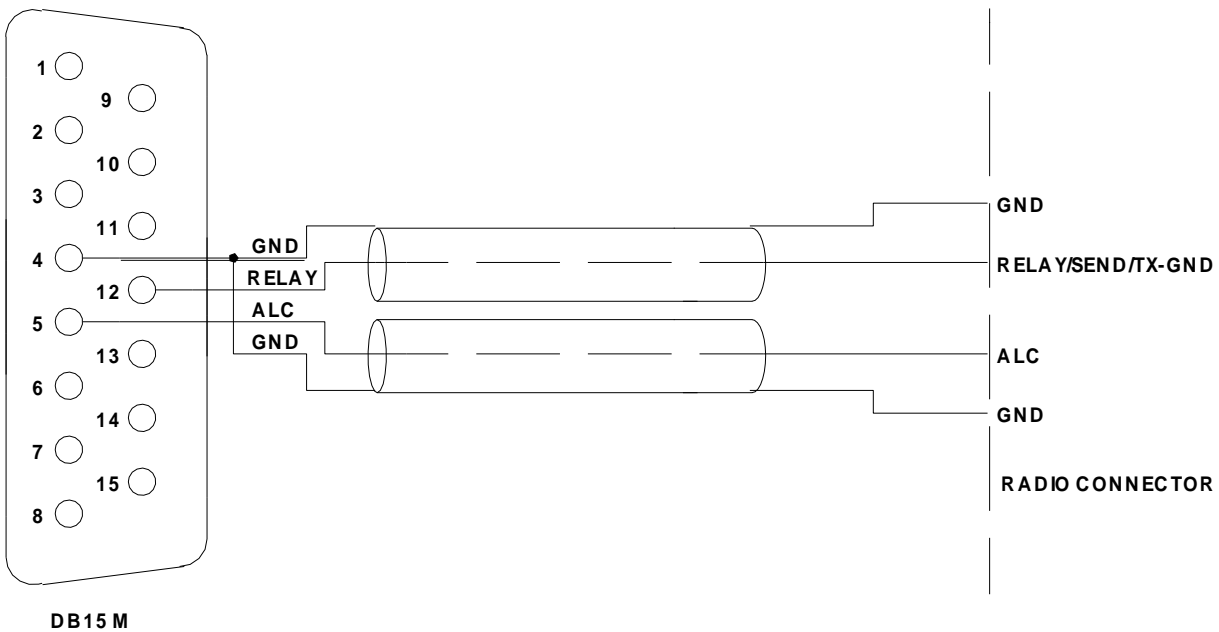

13.2 REMOTE ON LINK

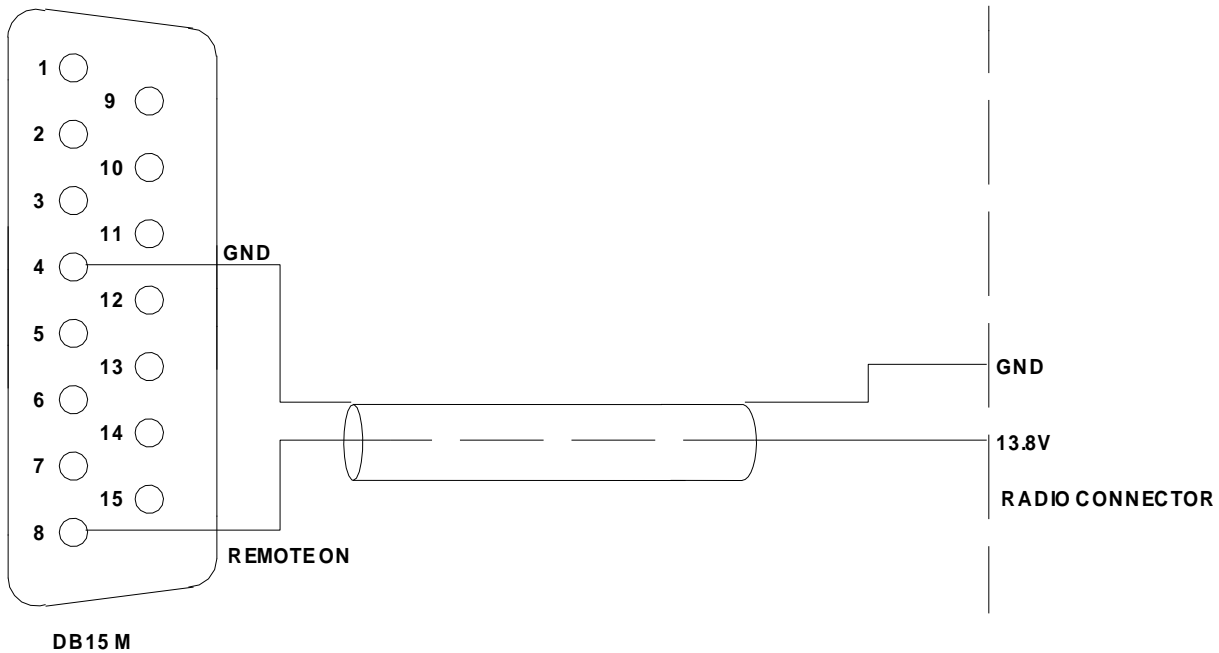

13.3 CONNECTIONS / TX-INH, TX-INH

All modern transceivers have a delay before the transmission to allow the linear to stabilize their relays avoiding damage to them and possible effects of "Hot Switching".

The Expert 2K-FA has a settling time of only 6.5 msec compatible with all modern transceivers (see the manual of the transceiver).

Some transceivers have an input (called TX-INHIBIT, LINEAR, MUTE, etc..) which disables the transmission.

This input can be used with transceivers that do not have such delay or, more generally, to improve the safety of switching.

The Expert 2K-FA has two outputs that can be connected to the TX-INHIBIT of the transceiver:

- a) TX-INH, usually gnd (550 ohm), stops the transmission when @ + 12V.
- b) / TX-INH, open collector normally off, stops the transmission when it goes to ground (on).

To choose a) or b) as well as to enable the TX-INHIBIT input, refer to the manual of the transceiver.

TX-INH Link

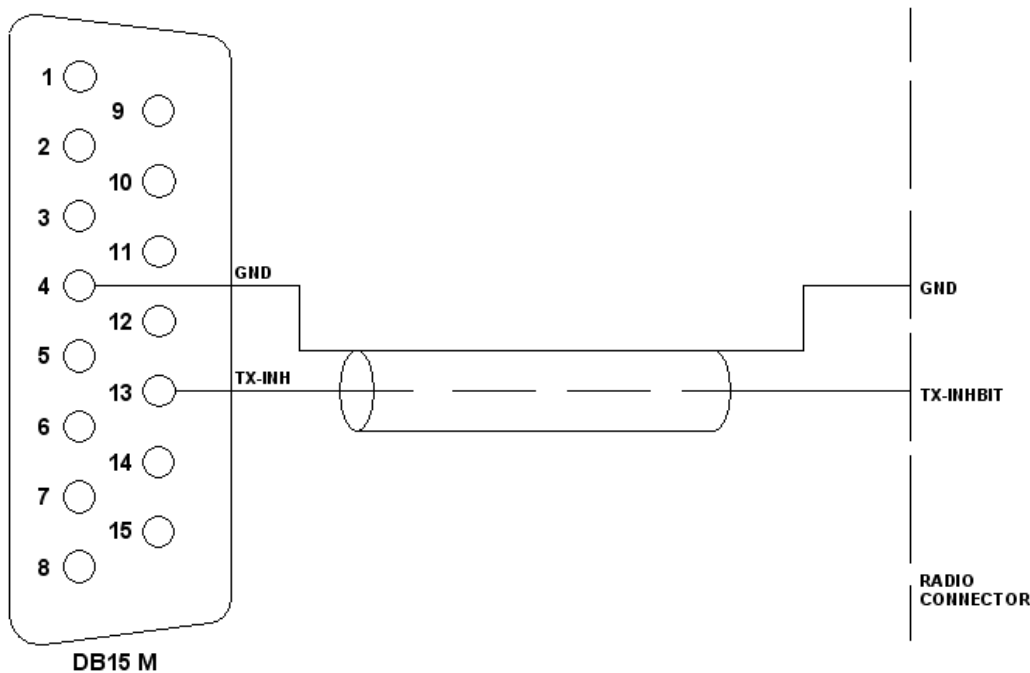

/TX-INH Link

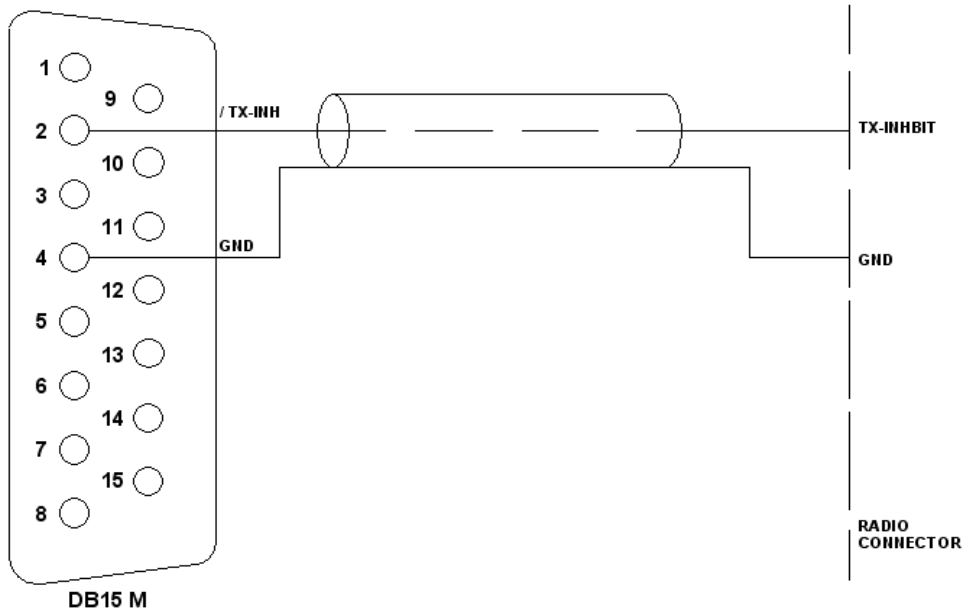

Note: WARNING, SPE is not responsible for any failure resulting from misuse of HW interface.

13.4 AUX Connector

This connector provides data on the bandwidth currently used in the two INPUT, indicating which input is connected to the antenna ANT 1/2/3/4/5/6 and which is connected to the SO2R. In this way you can know which of the two transceivers is currently connected to the output antenna set and when it is in transmission.

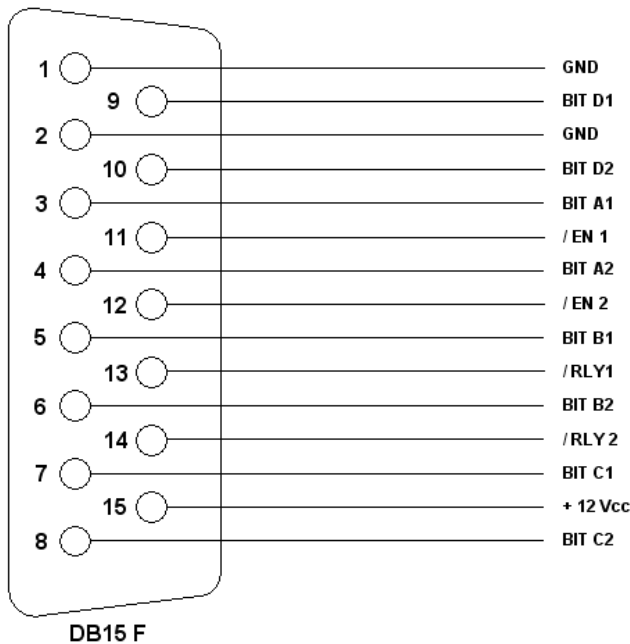

Pin n.	Pin name	Description
3	BIT A1	BIT A INPUT 1
5	BIT B1	BIT B INPUT 1
7	BIT C1	BIT C INPUT 1
9	BIT D1	BIT D INPUT 1
11	/ EN 1	INPUT 1 0 = not connected with ANT, 1 = connected with ANT
13	/ RLY 1	INPUT 1 0 = TX state 1 = RX state
1	GND	GND
4	BIT A2	BIT A INPUT 2
6	BIT B2	BIT B INPUT 2
8	BIT C2	BIT C INPUT 2
10	BIT D2	BIT D INPUT 2
12	/ EN 2	INPUT 2 0 = not connected with ANT, 1 = connected with ANT
14	/ RLY 2	INPUT 2 0 = TX state 1 = RX state
2	GND	GND
15	+ 12 Vcc	OUT + 12 Vdc 1 A max.

Each output is open collector

Note: WARNING, SPE is not responsible for any failure resulting from misuse of HW interface.

13.5 PORT Connector

This connector provides:

- Data about the ANT port in use (each output is open collector).
- RS 232 port for connection to a controller of a tunable antenna.
- RS 232 port for remoting use (excepted FIRST SERIES).

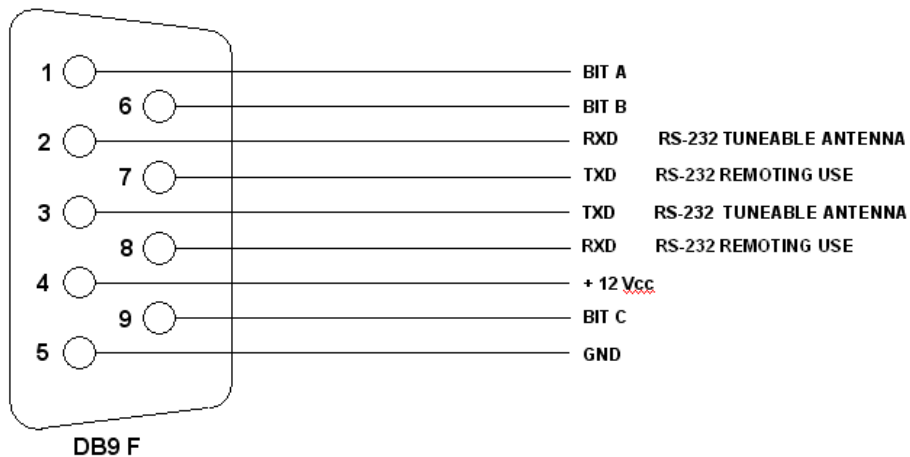

Pin n.	Pin name	Description
1	BIT A	BIT A antenna in use
6	BIT B	BIT B antenna in use
9	BIT C	BIT C antenna in use
5	GND	GND
2	RXD	RS232 port Tuneable Antenna
3	TXD	RS232 port Tuneable Antenna
7	TX_232 (formerly RTS)	RS232 port Remoting use
8	RX_232 (formerly CTS)	RS232 port Remoting use
4	+ 12 Vcc	+ 12 Vdc 1A max.

Note: In FIRST SERIES units, pins 7 and 8 were committed to RTS and CTS signals for Tuneable Antenna port.

When connecting to a control box of a tuneable antenna a suitable cable should be wired.

SteppIR cable

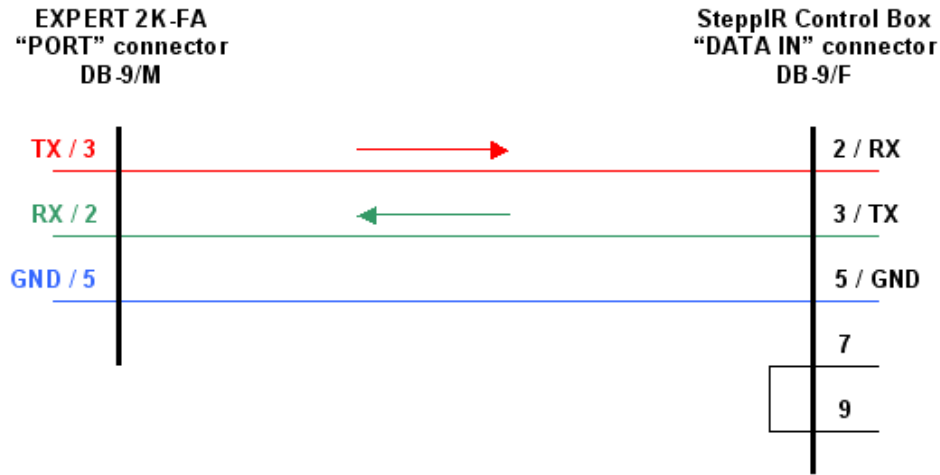

Ultrabeam cable

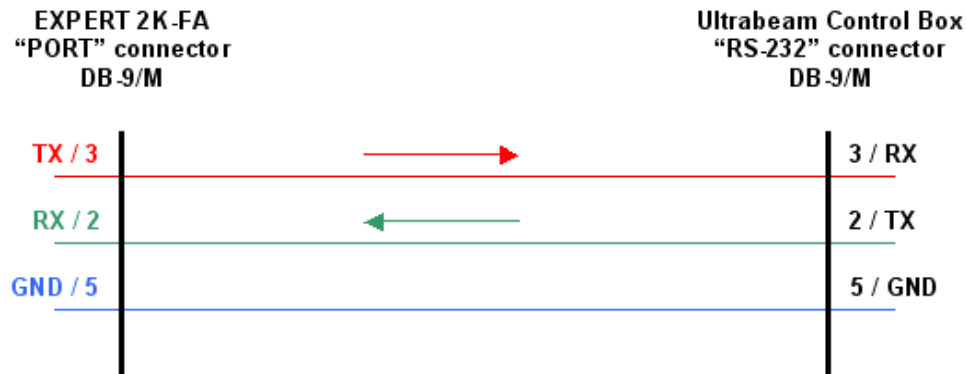

Note: **WARNING**, these types of antennas, sometimes need several seconds to be brought to resonance..
 Transmitting with high power while the antenna elements are still moving may cause damage to the antenna and the linear.
 To avoid this danger you can use some circuitry that inhibits the PTT during the movement of the motors, such as the "tuning relays" available from the antenna manufacturers.
 This solution is highly recommended.

Serial connection to a standard PC RS-232 port for remoting use

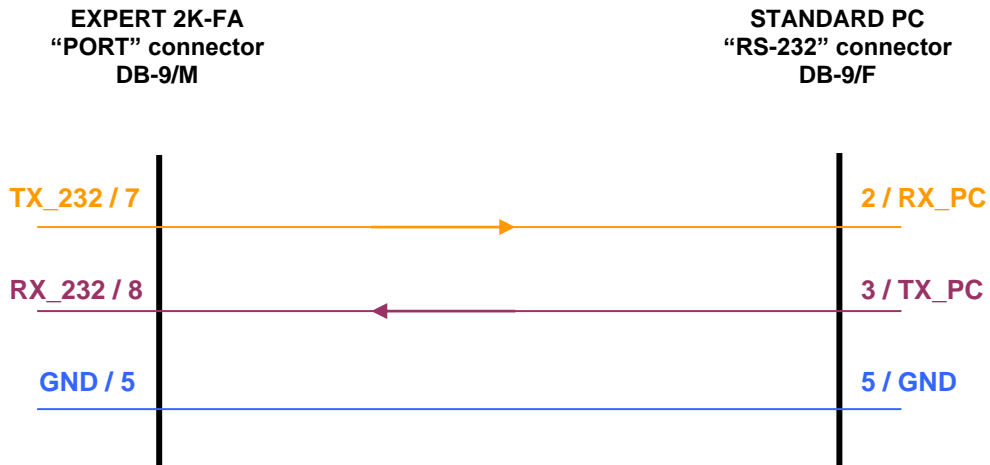

Note: *WARNING, SPE is not responsible for any failure resulting from misuse of HW interface.*

14. TRANSCEIVER CONTROLLED WITH A PC

If the transceiver is controlled with a PC using the CAT utility, the link with the amplifier can be made as described in the following paragraphs.

Note: BEWARE, SPE assures only the direct connection between the Linear and the Transceiver. The use of external control software could create malfunctions that must be resolved by the provider of such software.

14.1 ICOM CI-V INTERFACE

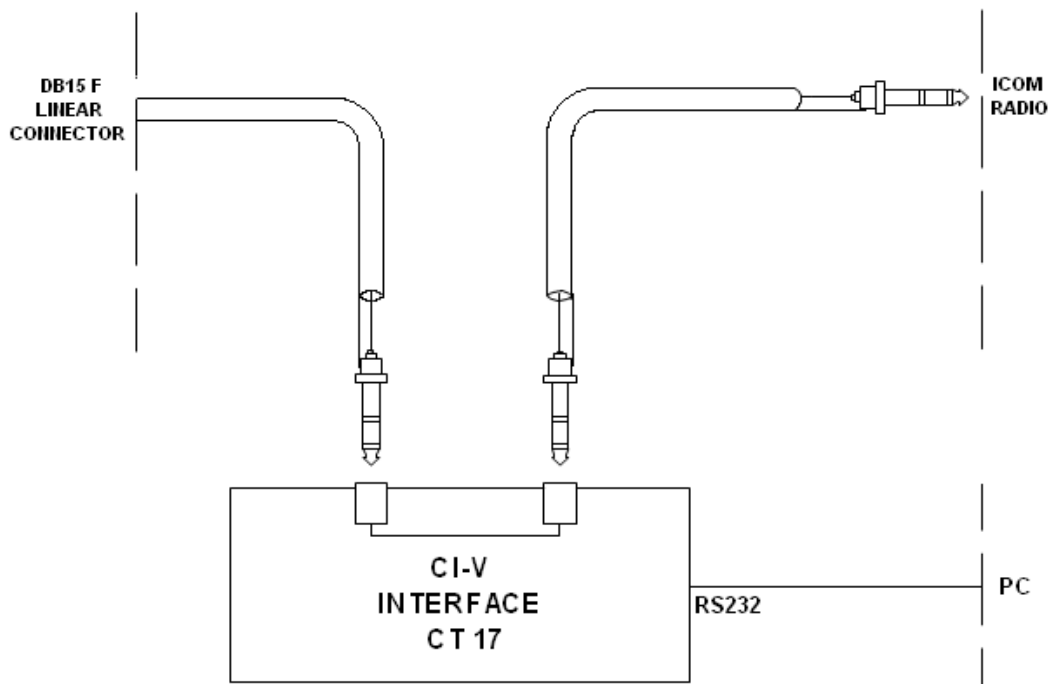

If the PC has an RS232 port, use a CT17 or similar interface and the standard cable for CI-V connection (see page 34).

If the PC has a USB ports only, use an external USB / RS232 converter.

If the transceiver has a USB CAT port, connect it directly to the PC and, with a standard CI-V cable, connect the Expert 1.5K-FA to the "REMOTE" connector of the transceiver.

The following types of connections as described in sections 14.2, 14.3 and 14.4 are common for Kenwood, Yaesu, TEN-TEC, Flex-Radio and ELECRAFT links. The DB-15 connector side of the amplifier remains the same. On the opposite end of the cable, it is necessary to connect only the GND and RX 232 (RX TTL) to the cable PC / Radio.

In this way, the interrogation to the transceiver is no longer requested by the linear but is requested by the PC. The linear analyzes only the data exchanged.

In this case, **DO NOT CONNECT the TX 232 (TX TTL) of the linear because it would create conflict in the software and could damage the hardware as well. (see following diagrams)**

14.2 RS232 INTERFACE

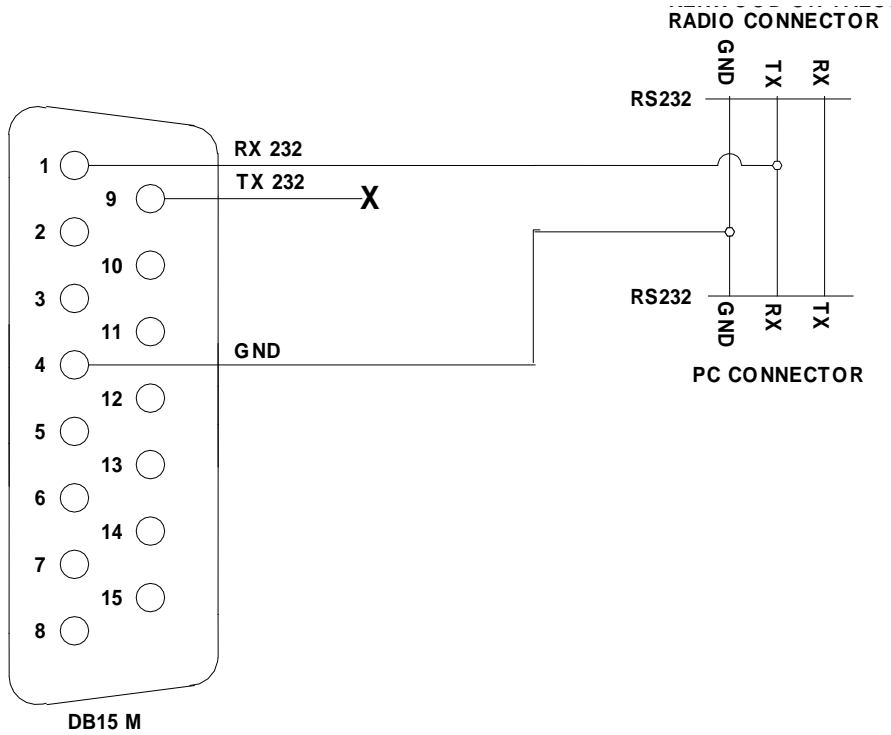

14.3 5V TTL KENWOOD INTERFACE

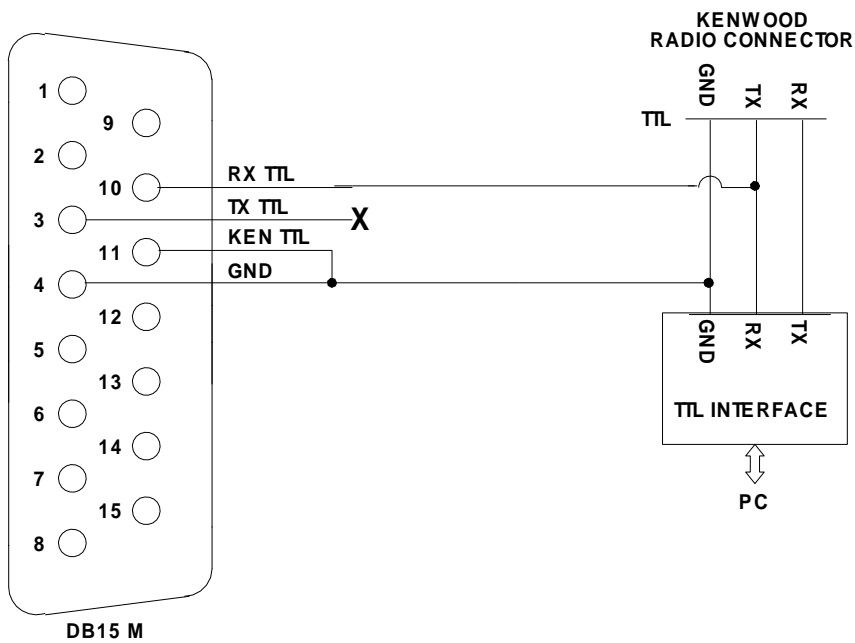

14.4 5V TTL YAESU INTERFACE

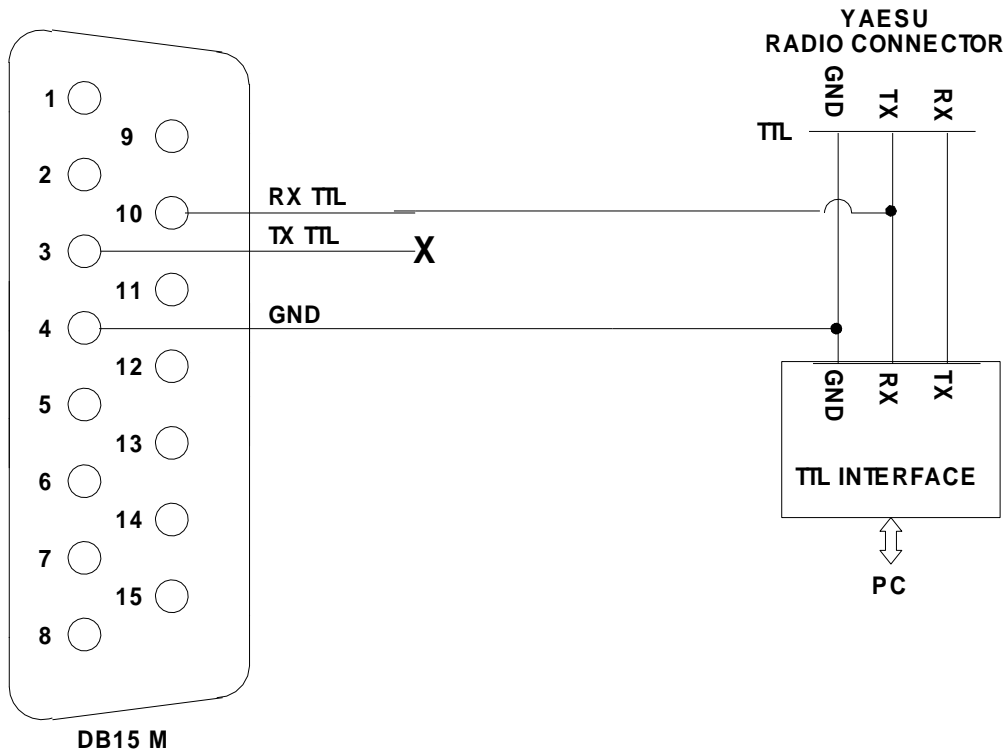

Note: WARNING, SPE is not responsible for any failure resulting from misuse of HW interface.

15. USB / RS 232 PORTS USAGE

Through the USB / RS232 ports on the rear panel it is possible to interface the amplifier with a PC.

Two features are possible

- a) To remote the linear.
- b) To download the successive versions of SW.

The USB port is recommended in order to directly link the linear with a PC. In this case the SW "Term_2K_USB" must be used.

The RS232 port (see "13.5 PORT Connector") is more suitable for internet use.

In this case the SW "Term_2K_232" must be used.

These ports are in alternative so they can't be used simultaneously.

15.1 REMOTE CONTROL

The software provided allows us to represent two separate windows.

The first provides an exact copy of the display, it is adjustable in size to fit any need on the control screen.

The second provides a copy of the keyboard. When not in use, it may disappear to make space on that screen.

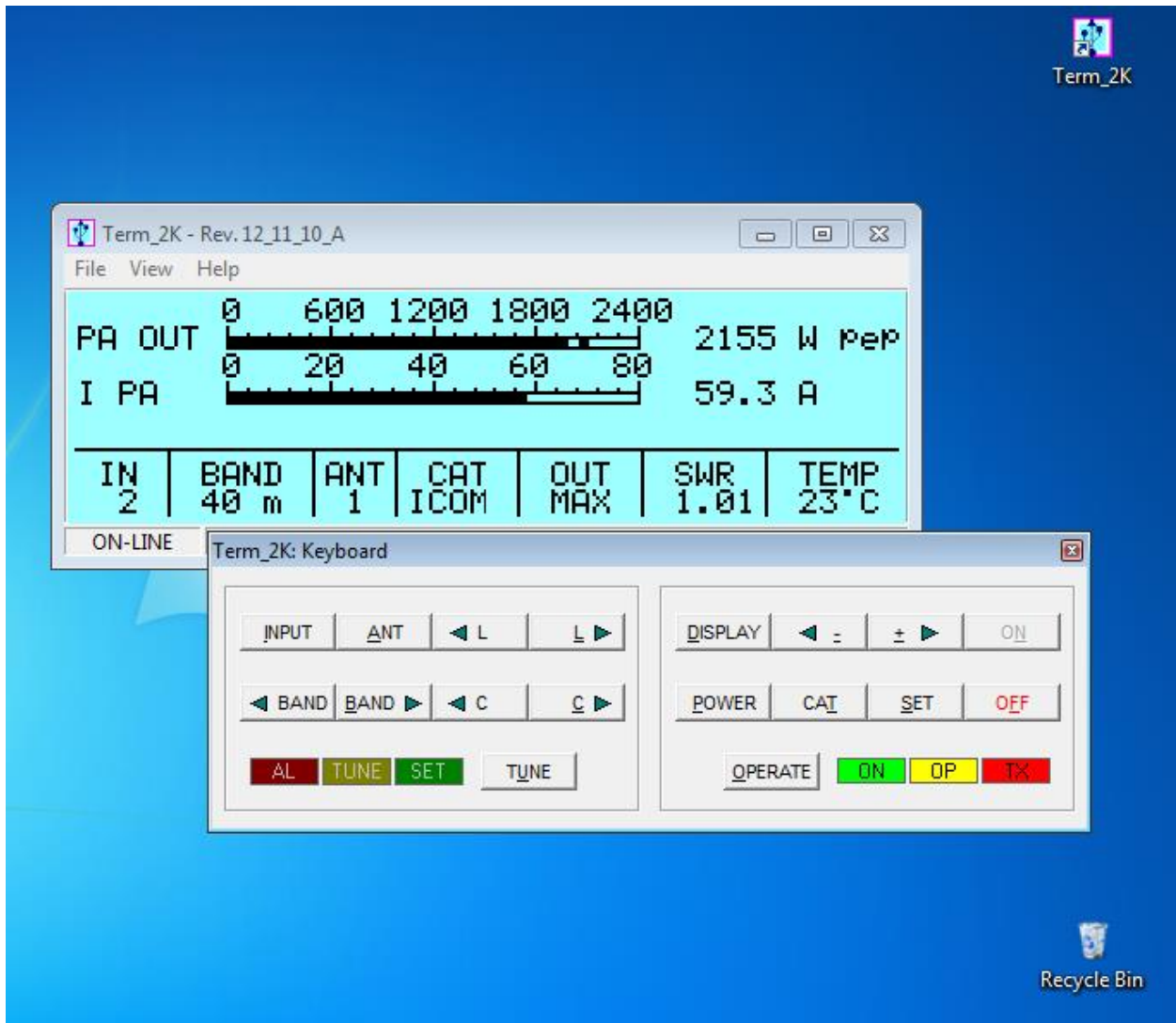

This software allows the same operation as when standing in front of the amplifier.

15.2 DOWNLOAD.

The Expert 2K-FA allows you to download any new versions of SW from the site www.linear-amplifier.com , following easy and intuitive steps.

“**Term_2K_Short_Guide**” is the document which describes the installation and the main features of the SW “Term_2K” (see Appendix 1 on this manual).

16. MAINTENANCE

If used in very dusty environments the air filter supplied separately can be installed behind the front panel grid.

Therefore the user only needs to periodically check and clean the air filter on the front panel (if any).

The frequency of air filter inspection depends how dusty the amplifier location is and how much it is used. We recommend monthly cleaning of the filter.

Twice yearly cleaning of the fans with a soft brush is also recommended.

To clean the filter

- a) Remove the front grid cover with the two small screws.
- b) Remove the filter and clean it with care.
- c) Reassemble the filter and the grid after having carefully cleaned the mechanical structure that includes them. Dry filter before re-installing.

Note: Check the filter if an unexpected rise of temperature of the linear is noticed.

Note: To allow the most efficient heat-dissipation of the power amplifier circuits, large copper parts have been used.

17. CHARACTERISTICS / SPECIFICATIONS

- **The smallest in its class.**

Built-in Power supply and Automatic Antenna Tuner..

Dimension: L 38, H 18.3, P 43 cm (14.96" W, 7.20" H, 16.93" D) (connectors included).

Weight: approx: 25 Kg.(55lbs).

- **The most technologically advanced in the world**

Two powerfull CPUs are used.

Over 35,000 lines of software for performance that cannot be found in any other amplifier at the same time.

- **Fully Automatic**

Easy connection with all models "ICOM, YAESU, KENWOOD, TEN-TEC, FlexRadio ELECRAFT" for immediate management of the bands, tuner and antennas. Same performance with all makes or homemade rigs.

The operator has only to move the "Frequency Tuning Knob" of the transceiver or clicking on the spot in the cluster !!!

- **Wide frequency coverage**

1.8 MHz to 50 MHz including WARC bands.

- **Fully solid state**

Up to 2 KW pep SSB, CW out; 50 MHz included.

MAX / MID (1KW) / LOW (500W) power selected according to the operator's power requirement, for digital modes and for linear protection (automatic).

No heating time, immediately ready!

Virtually limitless life of the amplification devices ((6 MOSFETs MRF151G).

- **Automatic Antenna Tuner built-in**

Capable of matching 5:1 SWR on HF, and 2.5:1 SWR on 6 meters.

Capable of programmable switching of 6 antennas (SO239 connectors).

Up to 3 antennas for the same band, one antenna can be set for reception..

Management of the SteppIR / Ultrabeam antennas (tuneable).

Measure also the SWR of the antenna / cable system.

Bands, Antennas, Tuning conditions are changed in 10 msec.

Bands, Antennas and Tuning conditions are managed also in "STBY" to support the exciter only.

Max. attenuation 0.8 dB.

Bypass capability.

- **SO2R**

- **Two inputs available.**

SO239 connectors.

- **High power gain (up to 14.5 dB).**

In "OPERATE" the required drive power is automatically set with an ALC connection and in "STANDBY" the exciter is automatically reset to full power.

- **Very clean and low distortion output!**

Spurious emissions less than -60 dB (50 MHz -65 dB).

3rd order distortion (two tone test) 36 dB typ.

- **Input 50 ohm always perfectly matched**
SWR less than 1.2:1.
- **Fully protected**
Temperature, Over-Voltage, Over-Current, SWR, Reflected Power, Max RF Tuner Voltage, Over-Drive, Open/Short Output. The correct parameters are continuously monitored.
The same protection is realized in two different ways:
 - Via hardware circuits (HW) to assure great speed.
 - Via the software (SW), to assure great accuracy.Thanks to the SW, transmit relay changeover is carried out with zero current at the contacts.
- **Full break-in operation (QSK)**
- **Quiet operation.**
Linear management of the speed of the cooling fans of the heatsink.
In the power supply, fans speed is reduced during the reception.
Since, considering the big power developed, a significant amount of heat must be removed, every precaution is used to keep the lowest possible the noise of the fans.
- **Continuous use**
“MAX” mode: SSB / CW unlimited.
Automatically limited to 1.5KW if a continuous signal is emitted in “MAX” for more than 15 sec.
“MID” “LOW” modes, RTTY unlimited.
- **Switching power supply.**
Continuous input between 190 – 255 Vac, 47-63 Hz.
PFC (Power Factor Correction).
- **The linear can be switched ON / OFF also switching the exciter ON / OFF**
- **Fully remotable.**
- **With a large LCD display is possible to have a great deal of info.**
W pep out, V pa, I pa, W, Temperatures, SWR (after and before the ATU), Input setting, CAT setting, Band and other indications including an alarms log.
- **Easy to operate**
Powerful SW gives you a user-friendly unit.
- **USB / RS232 ports .**
For remote control..
For new SW releases download.
- **Easy transportation**
A sturdy carry-bag is supplied for “QSY, FIELD DAY, DX’ PEDITIONS etc.“.
- **Certifications :**
CE, FCC, RCM (C-Tick)..

N.B. These specifications are subject to change without notice.

18. DIAGNOSTICS.

During normal working, the system performs a continuous monitoring of some measurements directly acquired from certain internal test-points.

When a dangerous situation is going to happen, a “serious” alarm message is raised and the amplifier is switched from **OPERATE** to **STANDBY**.

The user can either immediately restore the **Main Display Page** by pressing the **[DISPLAY]** key or wait for the visual alarm time-out expiration (about 10 seconds).

The following table shows all the system’s alarm messages that are recorded in the **Alarm History** stack:

Message	Description
SWR EXCEEDING LIMITS	Protection for SWR greater than 3:1.
INPUT OVERDRIVING	Protection for excessive input power.
EXCESS OVERHEATING	Protection because the internal temperature has exceeded safe limits.
COMBINER FAULT	Protection for unbalanced combiner.
POSSIBLE MODULE FAULT	The combiner temperature increases very fast

While the following table shows all the dynamic warning messages that are not recorded in the **Alarm History** stack:

Message	Description
BAND NOT PERMITTED	Band not allowed or not set.
ANTENNA NOT AVAILABLE	Antenna not set.
TX ANTENNA NOT AVAILABLE	In the selected band is set only one antenna for reception.
STEADY OUTPUT POWER EXCEEDING LIMITS	Appears when in "MAX" is transmitted a digital or continuous signal, the linear switches automatically in "MID".
INTERNAL OVERHEATING	Appears when the internal temperature reaches 75 ° C (167 ° F), the linear automatically switches to the power level immediately below.
HIGH SWR ANTENNA: TUNING NOT ALLOWED	When the antenna SWR is over 3.5:1, the auto tuner is not enabled to operate.
ATU BYPASS: TUNING NOT ALLOWED	Since the tuner is bypassed, it is not possible any matching nor automatic nor manual.
NO INPUT POWER: TUNING HALTED	The tuner can not work for to low input power.
CAN'T SWITCH-OFF: POWER HELD BY REMOTE	The amplifier does not turn OFF by the keyboard because it is kept ON by a remote device (transceiver or USB port).
COMBINER OVERHEATING	Indicates that the amplifier is going to go into protection for "COMBINER FAULT. "

The “COMB. BAL.” on the Display is defined by two numbers:

- First shows how the temperature of the combiner circuitry increases in one minute.
- Second shows the absolute temperature of the combiner circuitry.

19. TABLE

BAND TABLE, SUB-BAND, CENTRAL FREQUENCY SUB-BAND

160 m	[0] 1785	[1] 1795	[2] 1805	[3] 1815	[4] 1825	[5] 1835
	[6] 1845	[7] 1855	[8] 1865	[9] 1875	[10] 1885	[11] 1895
	[12] 1905	[13] 1915	[14] 1925	[15] 1935	[16] 1945	[17] 1955
	[18] 1965	[19] 1975	[20] 1985	[21] 1995	[22] 2005	[23] 2015
80 m	[24] 3470	[25] 3490	[26] 3510	[27] 3530	[28] 3550	[29] 3570
	[30] 3590	[31] 3610	[32] 3630	[33] 3650	[34] 3670	[35] 3690
	[36] 3710	[37] 3730	[38] 3750	[39] 3770	[40] 3790	[41] 3810
	[42] 3830	[43] 3850	[44] 3870	[45] 3890	[46] 3910	[47] 3930
	[48] 3950	[49] 3970	[50] 3990	[51] 4010	[52] 4030	
40 m	[53] 6963	[54] 6988	[55] 7013	[56] 7038	[57] 7063	[58] 7088
	[59] 7113	[60] 7138	[61] 7163	[62] 7188	[63] 7213	[64] 7238
	[65] 7263	[66] 7288	[67] 7313	[68] 7338		
30 m	[69] 10075	[70] 10125	[71] 10175			
20 m	[72] 13975	[73] 14025	[74] 14075	[75] 14125	[76] 14175	[77] 14225
	[78] 14275	[79] 14325	[80] 14375			
17 m	[81] 18075	[82] 18125	[83] 18165			
15 m	[84] 20975	[85] 21025	[86] 21075	[87] 21125	[88] 21175	[89] 21225
	[90] 21275	[91] 21325	[92] 21375	[93] 21425	[94] 21475	
12 m	[95] 24891	[96] 24963	[97] 25038			
10 m	[98] 28050	[99] 28150	[100] 28250	[101] 28350	[102] 28450	[103] 28550
	[104] 28650	[105] 28750	[106] 28850	[107] 28950	[108] 29050	[109] 29150
	[110] 29250	[111] 29350	[112] 29450	[113] 29550	[114] 29650	[115] 29750
6 m	[116] 49875	[117] 50125	[118] 50375	[119] 50625	[120] 50875	[121] 51125
	[122] 51375	[123] 51625	[124] 51875	[125] 52125	[126] 52375	[127] 52625
	[128] 52875	[129] 53125	[130] 53375	[131] 53625	[132] 53875	[133] 54125

Note: [sub-band] Central frequency KHz

20. Appendix 1 “Term 2K Short Guide”

Overview

With reference to what described at Section 15. “USB / RS 232 PORTS usage”, this appendix contains the following sections:

SW installation

Term_2K_USB.exe usage

Term_2K_232.exe usage

Firmware update

The host PC must have a correctly installed Windows XP or a further release of Microsoft’s operating system; just a minimum RAM amount and hard disk space is required.

20.1 SW installation.

The installation package is contained into a compressed **.ZIP** archive named “**Term_2K_Package_2_0.zip**” which requires to be expanded in a working folder and then processed as hereafter described. This package is recorded into the equipped CD or can be downloaded from our website www.linear-amplifier.com.

Once the compressed archive **Term_2K_Package_2_0.zip** has been previously stored into a working folder. It must necessarily be expanded, that is all the files therein contained must be extracted and properly placed to the host system.

In this example the compressed archive **Term_2K_Package_2_0.zip** has been placed into a folder named **Tmp** which is contained into the local disk unit **C:** as shown in the picture below:

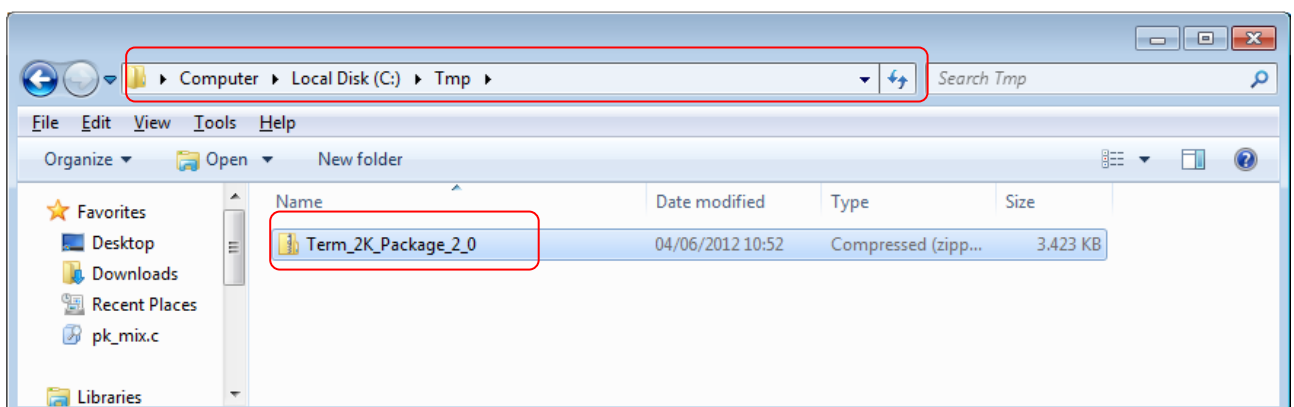

The next step is the archive expansion, and this can be obtained by selecting the filename and then right-clicking over it; a local menu will appear, and its **Extract All...** item will pop-up the following pre-compiled form:

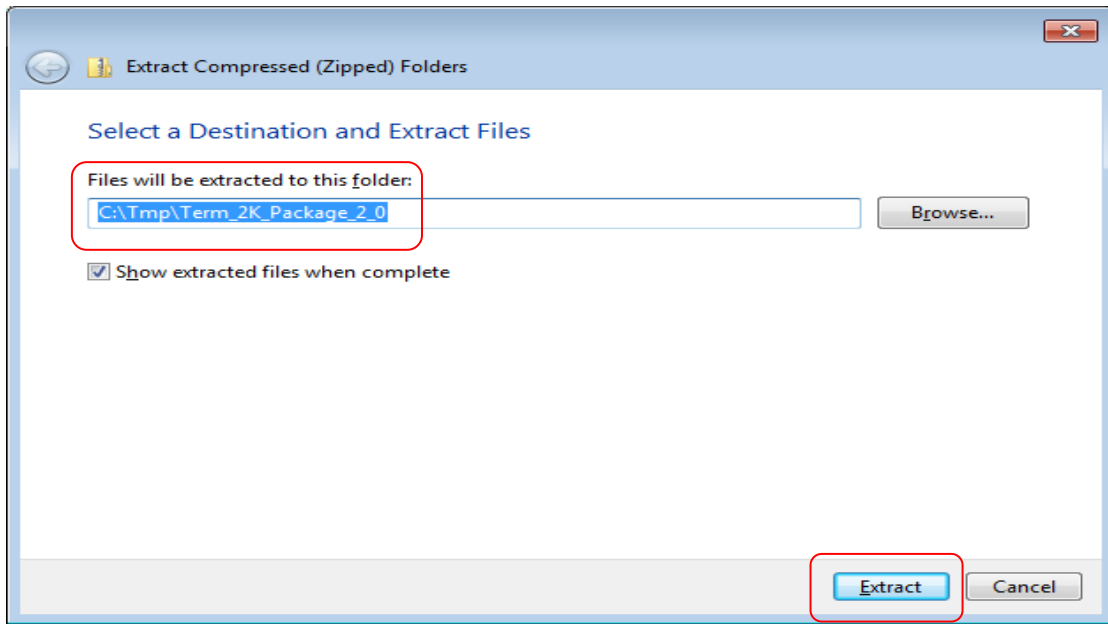

The proposed destination folder is good for our purpose, so let's close this operation by using the **Extract** key marked in the picture above.

This final result will be a new uncompressed folder having the same name of the compressed one belonging to the original installation package. Everything is contained into our working directory as shown in the picture below:

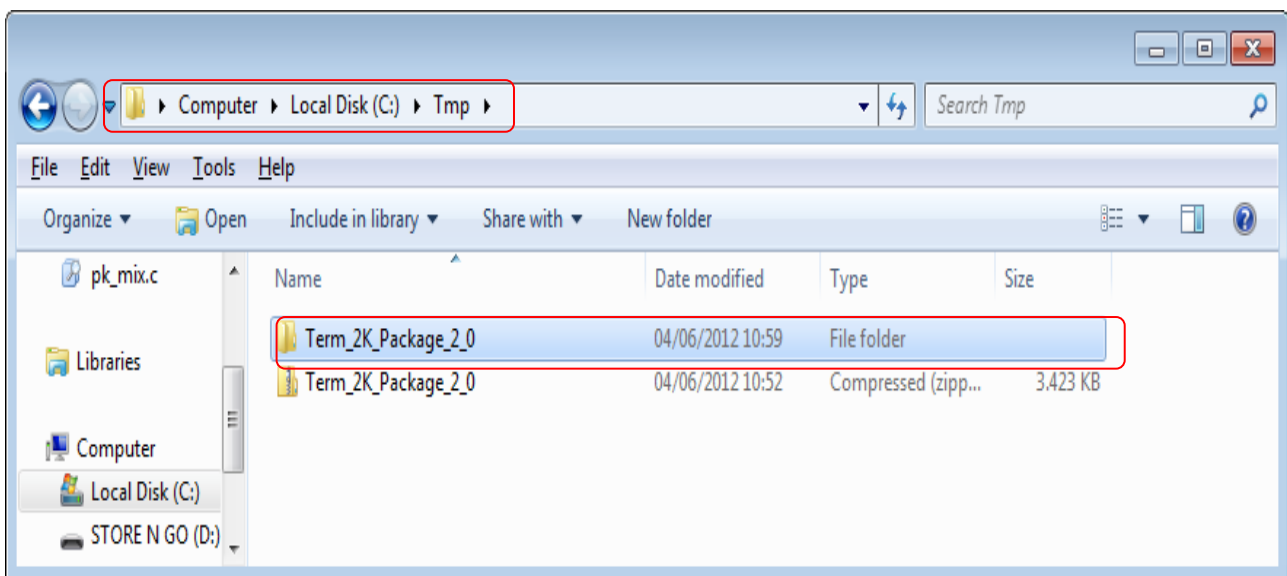

Once opened, the **Term_2K_Package_2_0\Term_2K_Package_2_0** will show the following folder contents:

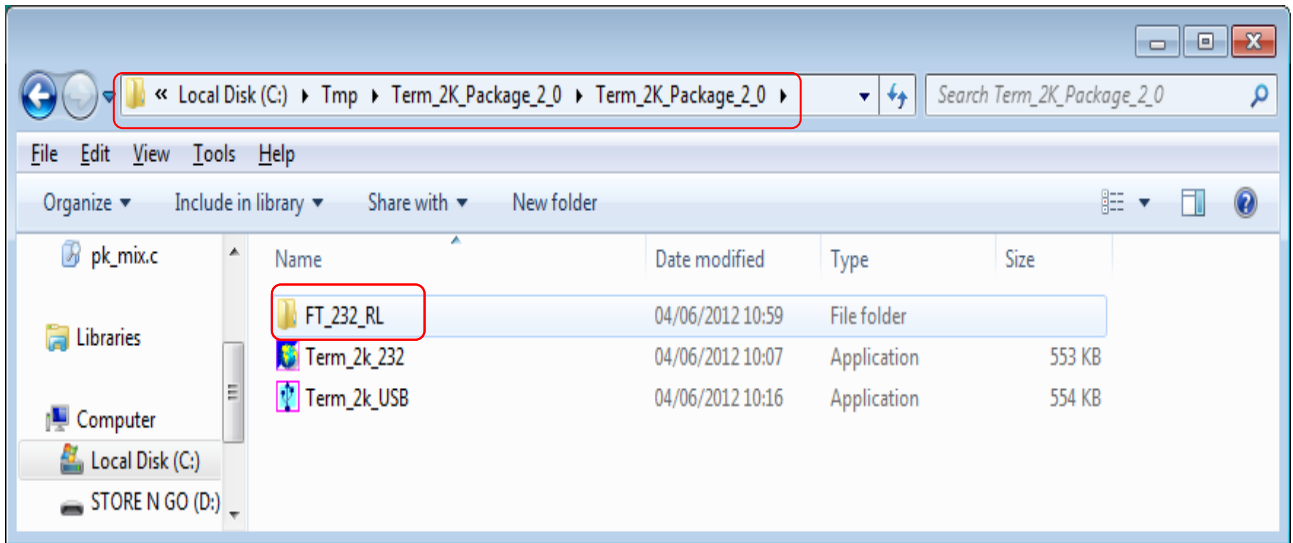

Where:

FT_232_RL is a folder containing the USB drivers and an automatic installation program, which must be run once to prepare the operating environment and that provides to sort out everything is needed (USB drivers and their support files...) on the Windows host system.

Term_2K_USB.exe is the remote control application that can be launched only after having properly installed the USB drivers.

Term_2K_232.exe is the remote control application especially designed to establish a connection using the special RS-232 serial port available on the **EXPERT 2K-FA Second Series** rear panel (that hardware is not available on **First Series** units).

After a left-button mouse click the following folder report will appear:

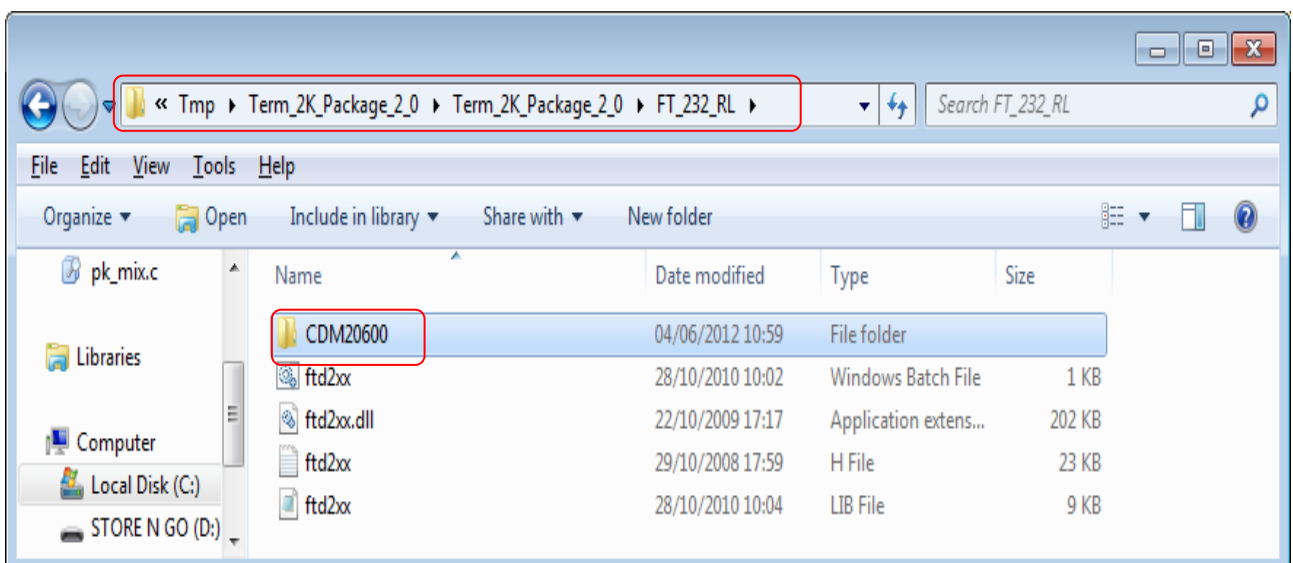

The most interesting thing for us is the **CDM20600** folder which contains, among the other things, the **CDM20600.exe** Windows application marked in the picture below:

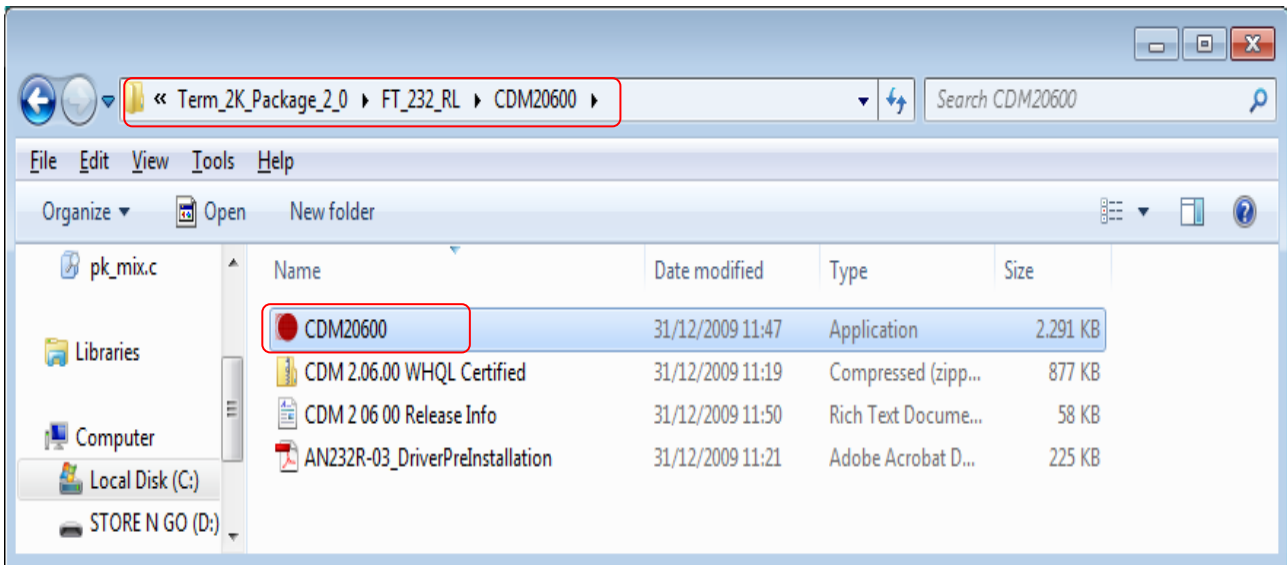

This application has the purpose of properly installing the USB drivers.

So, **without making any physical link between the EXPERT 2K-FA and the PC**, let's double-click, using the mouse left-button, over the "red ball" icon of **CDM20600.exe** application and wait for its preparatory job completed.

As soon as **CDM20600.exe** starts running, a DOS windows similar to one of the following picture will pop-up for several seconds and it will disappear after its automatic preparatory job's completion.

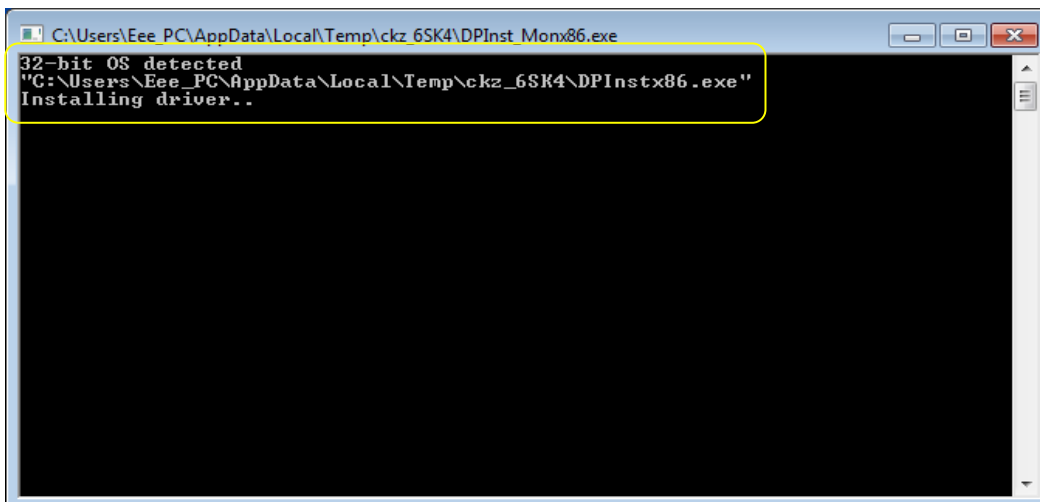

The next step is to connect the PC and the EXPERT 2K-FA using the equipped USB cable and wait the recognition of the new USB connection. After then a notification windows will pop-up, as shown in the picture below.

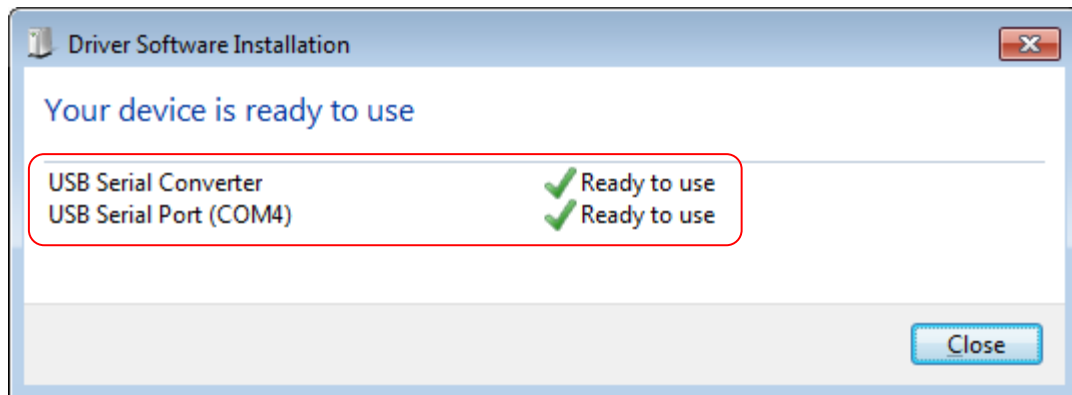

The USB port installation and setting is now complete. Now that this fundamental step has been successfully completed, the **Term_2K_USB.exe** remote control application can be launched. For this purpose a back-step to the starting uncompressed folder **Term_2K_Package_2_0** must be made and a double-click with the mouse left-button on the application filename must follow it, as shown in the picture below

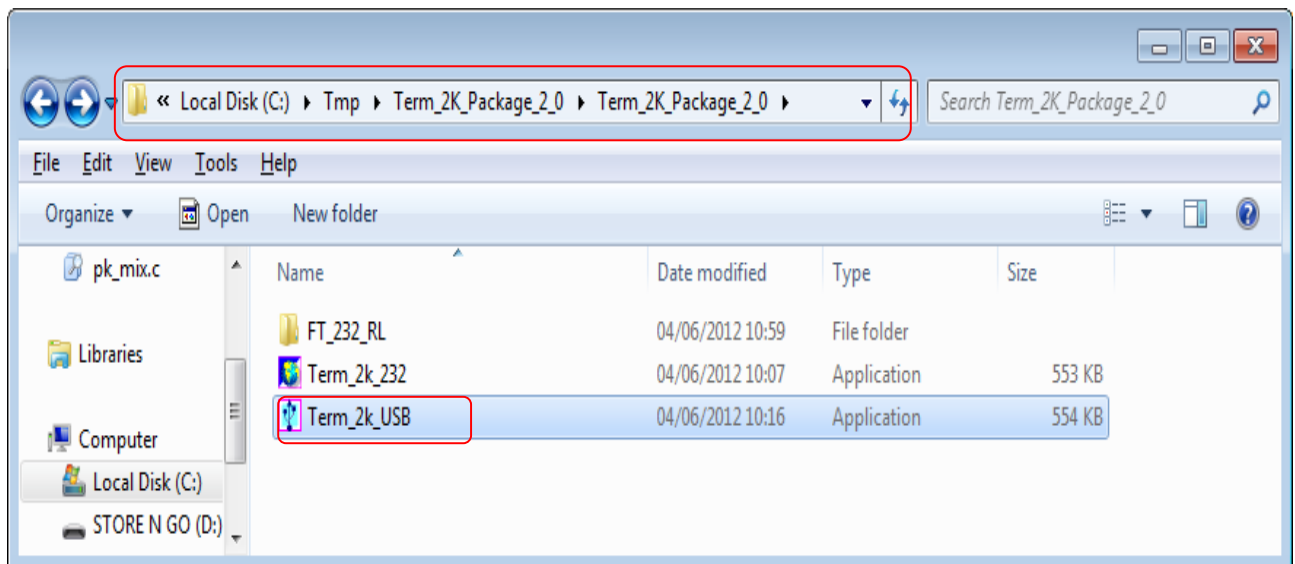

20.2 Term_2K_USB.exe usage

It is warmly suggested to create a link to the application on the desktop.

As a first try, let's double-click on the application's icon (the USB symbol), using the mouse left-button, just to see if everything works fine.

It is warmly suggested to create a link to the application on the desktop.

As a result the application window will show off, as in the following picture:

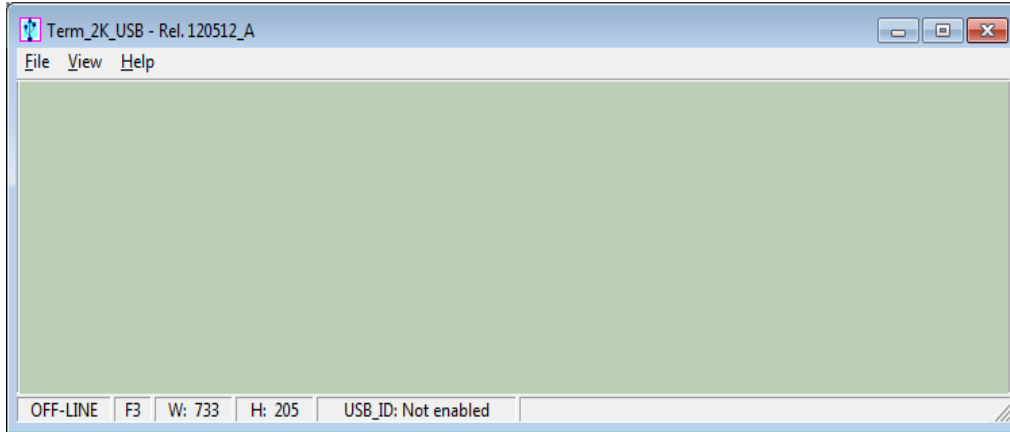

This is the main window of **Term_2K_USB.exe** application.

It is a realistic hardcopy of the **EXPERT 2K-FA** LCD display, and it is also equipped with a pop-up virtual keypad having almost the same look and feel as the rear one placed on the **EXPERT 2K-FA** front panel.

To activate/deactivate this keypad the user must check/uncheck the **View/KeyPad On/Off** menu item as shown in the following screen snapshot:

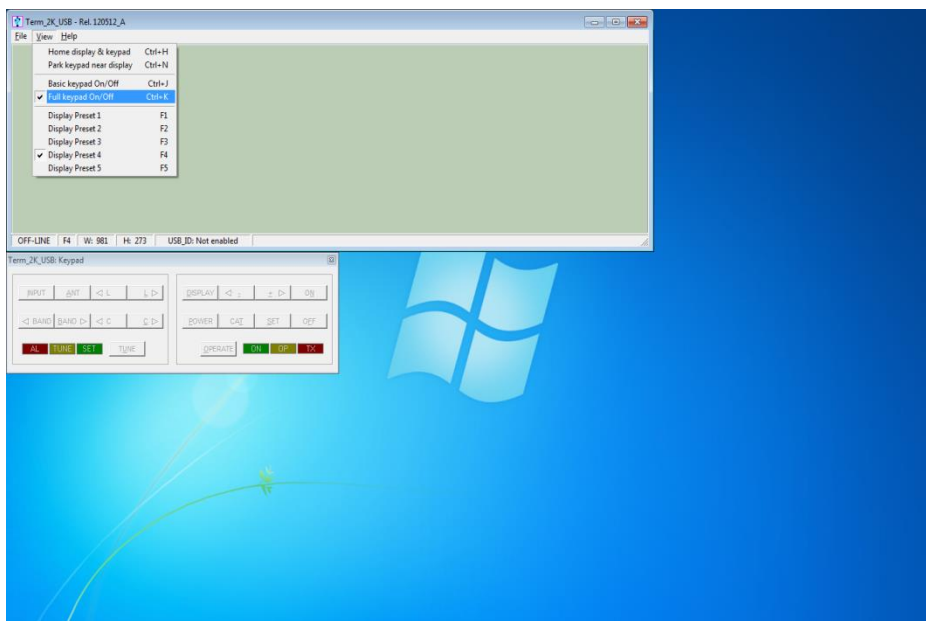

View menu also contains five items related to the application window size presets which can be either selected by the menu itself or by their equivalent [F1 ... F5] shortcut keys. Feel free to test all the **View** menu options in order to find an optimal and comfortable vision of the display main window.

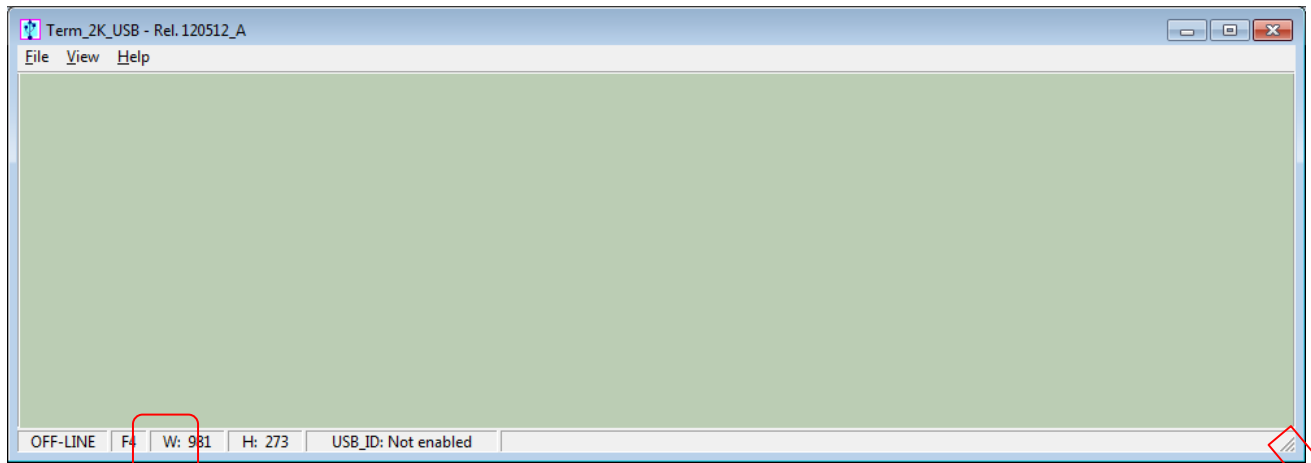

Anyway the display window can be easily redimensioned (that is: enlarged or reduced...) by acting on the right-bottom corner of the window using the mouse as depicted in the picture above.

In case the user wants to restore the original size-preset behind any [F1...F5] key, he must select the **Fx** preset and, then, press the **Ctrl+Fx** key combination on his PC keyboard.

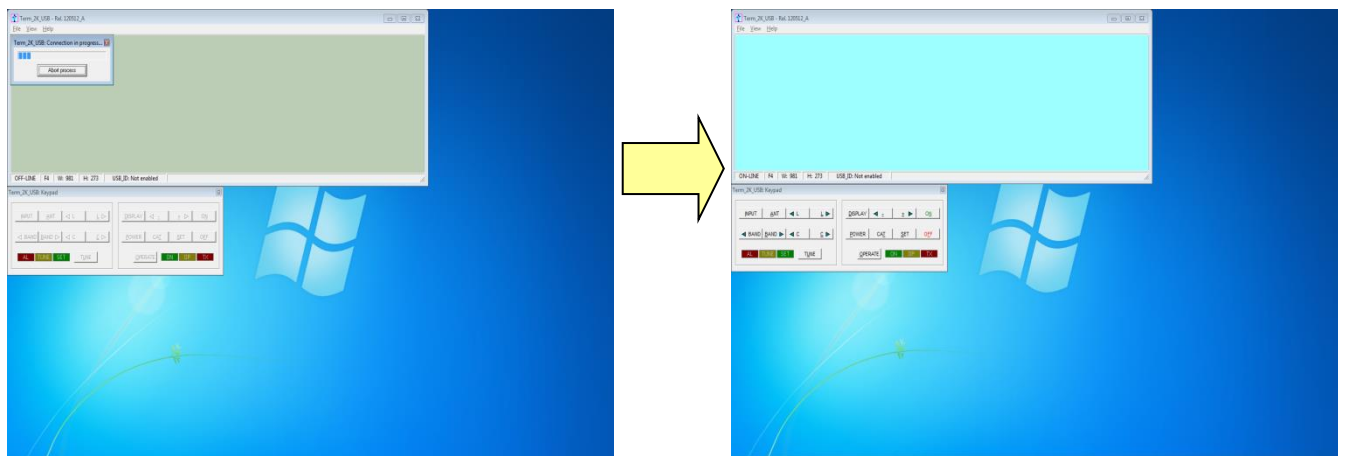

When **Term_2K_USB.exe** gets launched an automatic **Connect** command also starts and, if a USB link to the linear amplifier was already active, it should have shown a result similar to the picture sequence above.

In case it won't happen, the user can also try connecting using the **File/Connect** menu item (or using its equivalent **Ctrl+Q** shortcut key...).

The final visual result will be a "bright backlight" display and a function-keys enabling on the virtual keypad.

In case the **EXPERT 2K-FA** were already switched on after the connection established by **Term_2K_USB.exe**, an immediate update on the current display contents would result.

In case the **EXPERT 2K-FA** were switched off, it would be turned on by using [**ON**] virtual key on the application keypad.

The same way, all the other virtual keypad keys perform the same actions as their equivalent mechanical keys forming the real front panel keyboard of the **EXPERT 2K-FA**.

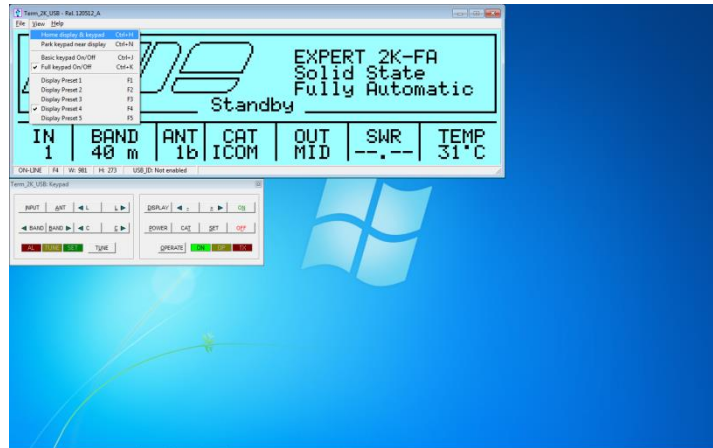

View menu is also equipped with the useful **Home...** and **Park...** items which have been especially designed to allow an automatic repositioning of the application along the PC desktop area.

In more details:

- **Home... (Ctrl+H)** item positions the display window to the upper-left corner of the desktop area and aligns the keypad to its bottom edge.
- **Park... (Ctrl+N)** item leaves the display window where it currently stays and just aligns the keypad to its bottom edge.

The above described operations could be helpful whenever a quick and safe repositioning of the application windows is required.

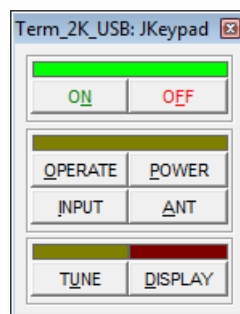

The **Basic keypad...** item in **View** menu allows to set a reduced-size keypad, having fewer keys than the complete keypad, which could be useful when no setting actions are required on the linear amplifier.

Note: despite the keypad types (Full and Basic) are certainly useful since they both can be directly accessed using the mouse pointer, it is helpful to know that all the operations allowed using the virtual keys can be also performed using short commands directly typed on the PC keyboard.

The following one is the “shortcut-keys” table:

2K-FA Function key	Equivalent shortcut-key from the PC keyboard
[INPUT]	I
[ANT]	A
[<L]	Ctrl+L
[L>]	L
[<BAND]	Ctrl+B
[BAND>]	B
[<C]	Ctrl+C
[C>]	C
[TUNE]	U
[DISPLAY]	D
[< -]	-
[> +]	+
[ON]	N
[POWER]	P
[CAT]	T
[SET]	S
[OFF] (*)	F
[OPERATE]	O

(*) Please bear in mind that [OFF] command (either from virtual keypad or by shortcut key...) always asks for a confirmation to its amplifier shutdown operation by using the dialog form below:

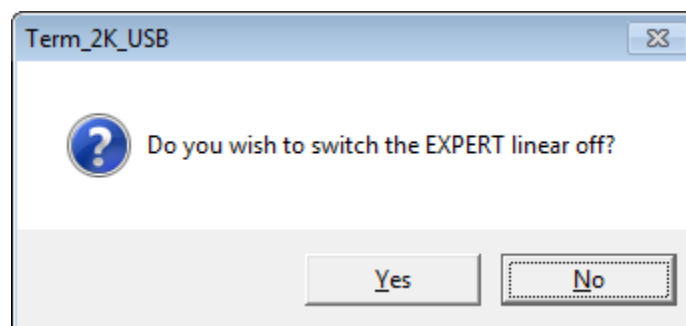

Note: it could happen that, trying to connect the linear amplifier to the PC, some problems could arise because other peripherals sharing the same USB internal hub conflicts to it. To avoid this kind of conflict it is necessary to go to selective addressing.

Selective addressing thru USB port.

This options has been designed to allow a selective addressing of an EXPERT linear amplifier connected to any given PC USB port.

Differently from other similar devices using the popular FT232RL USB microcontroller, where the most used way for providing selective addressing of a specific device is based upon its serial port ID parameter (e.g. COM1, COM2, etc.), or method is based upon a unique feature of the popular FTDI chip which is known as “ID String Property”.

This is a sequence of 8-alphanumeric characters, programmed by the FT232RL’s manufacturer during the production process, which something similar to the MAC address peculiar to any PC LAN card.

From here the consideration that this unique coding parameter doesn’t allow addressing ambiguity when correctly applied to FDTI chips connected to the same USB bus.

Preliminary programming for “ID string property” within Term_2K_USB.exe .

This special setting, based upon an easy “self-learning” procedure, must be performed once and with the **EXPERT 2K-FA** having previously put **OFF-LINE**.

Select **File/Configure USB connection...** from the main menu as shown in the picture below:

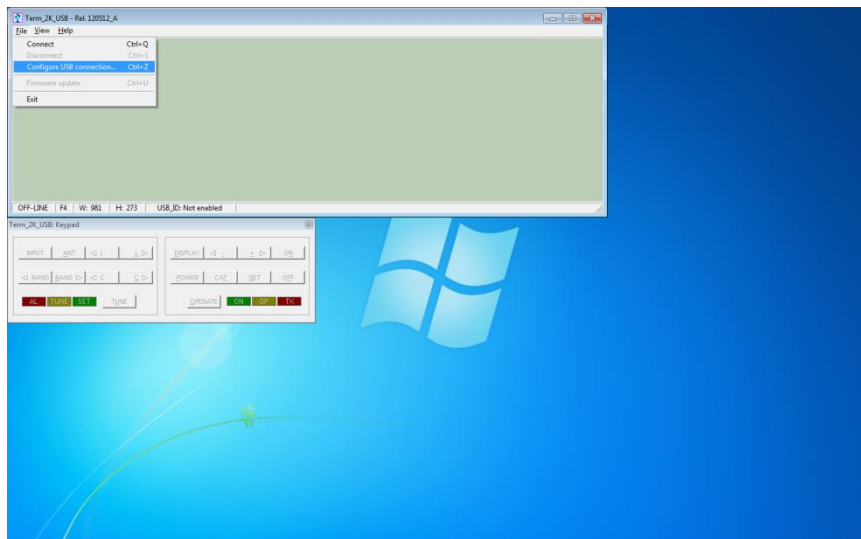

A dialog window, as shown in the picture below, will pop up:

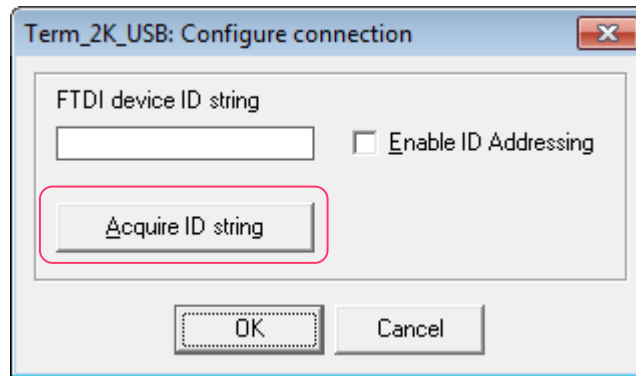

The user is simply required to press the **Acquire ID string** key, marked in the picture above, in order to start the **ID string** characters acquisition process across the USB data-link (guided self-learning procedure...).

In case more than one USB chip are linked to the system (directly or indirectly thru an external USB hub...) the following notification pop-up window will be shown:

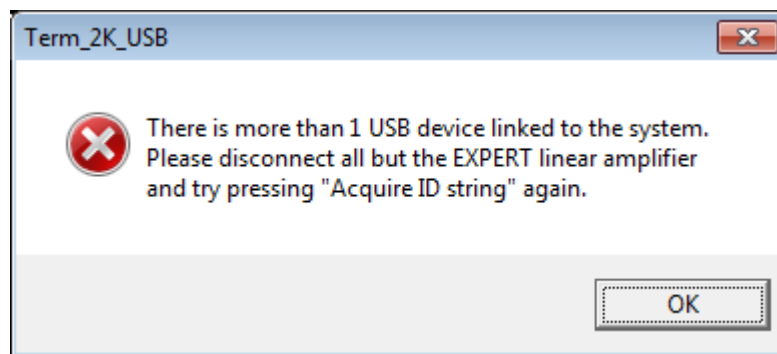

In such a case the user is invited to disconnect all the devices but his EXPERT 2K-FA and retry again using the acquisition procedure above described.

In case the user detaches all the connected devices (the linear amplifier as well...) the **Term_2K_USB.exe** acquisition system would notify that by rising the following self-explaining pop-up message to the user:



In case of a successful acquisition process, the following pop-up notification message would be raised instead:

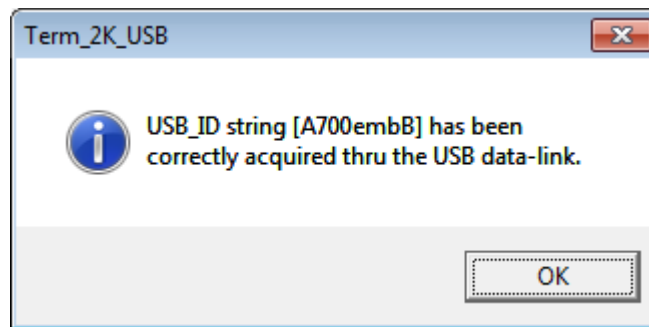

The picture above shows the acquisition report of a device whose **ID String Property** is **A700embB**.

As explained earlier, this parameter is unique to any specific chip, so it doesn't allow duplicates.

As soon as the notification message gets validated, using its OK key, the dialog form previously popped will appear properly filled-in as the following picture shows:

Once the user validates the data acquisition by pressing the OK key marked in the picture above, the **Term_2K_USB.exe** internal database will be properly updated and,

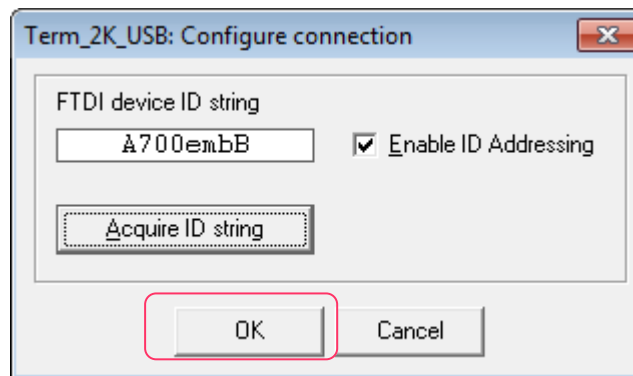

As a confirmation of that, the application status bar will be properly updated as the following picture shows:

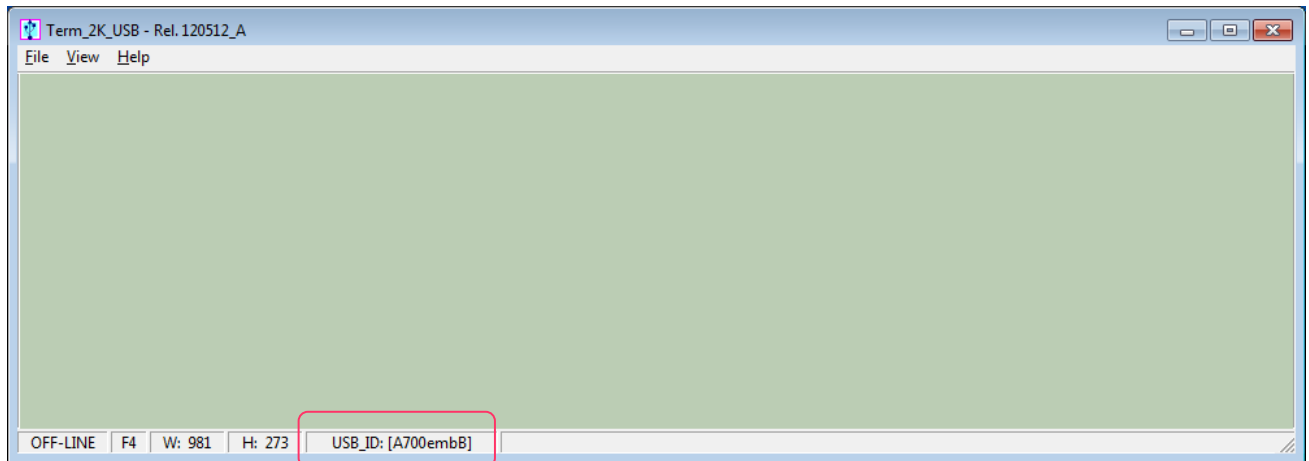

Once the above described steps get completed **Term_2K_USB.exe**, will only be able to recognize and address the **EXPERT 2K-FA** whose (unique) **ID String** matches to the one written after the **USB_ID:** label of the picture above.

As explained earlier, this setting is permanent so, there is absolutely no need to repeat the acquisition procedure described so far any time the user wants to connect to that specific EXPERT 2K-FA unit.

Of course the acquisition procedure must be restarted again in case another EXPERT 2K-FA linear amplifier would require to be addressed; that is because another device has got, by force of circumstances, another **ID String** parameter to properly reconsider.

After having carried out all the setting and configurations steps listed in the earlier pages, everything's ready for using the FT232RL selective addressing features described so far.

All the operations tied to the **C**onnect / **D**isconnect menu items are still the same as in the case of non-selective addressing procedure.

A last note.

If, for whatever reason, all the selective addressing capabilities are no longer needed to open a connection to an EXPERT 2K-FA thru its USB link, they can be temporarily disabled.

This operation is quite easy to perform.

After having recalled the **Configure USB connection** dialog form using its specific item contained into the **F**ile menu, uncheck with a mouse click the **E**nable **ID Addressing** option, as shown in the following picture, and validate this entry using the **OK** button.

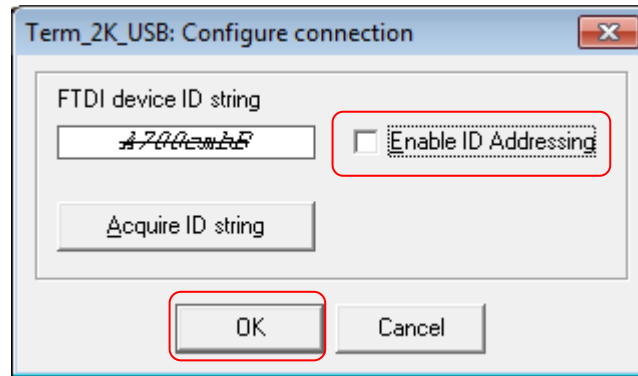

This new setting will be notified in the application status bar with the “**Not enabled**” attribute following the **USB_ID:** label, as shown below

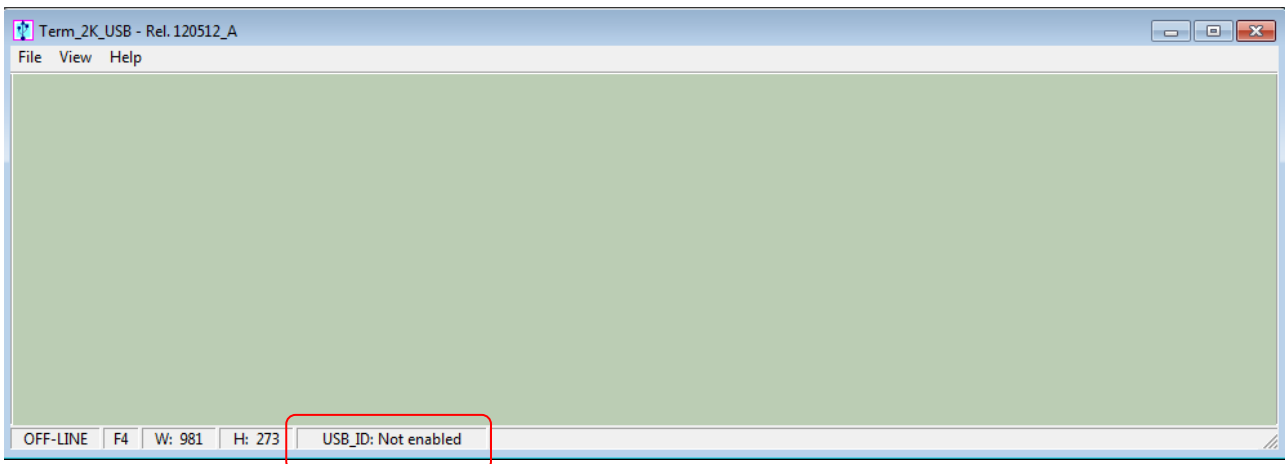

20.3 Term_2K_232.exe usage

To start running **Term_2K_232.exe** application it is necessary to step back into the **Term_2K_Package_2_0** uncompressed folder and select the related filename as shown in the picture below:

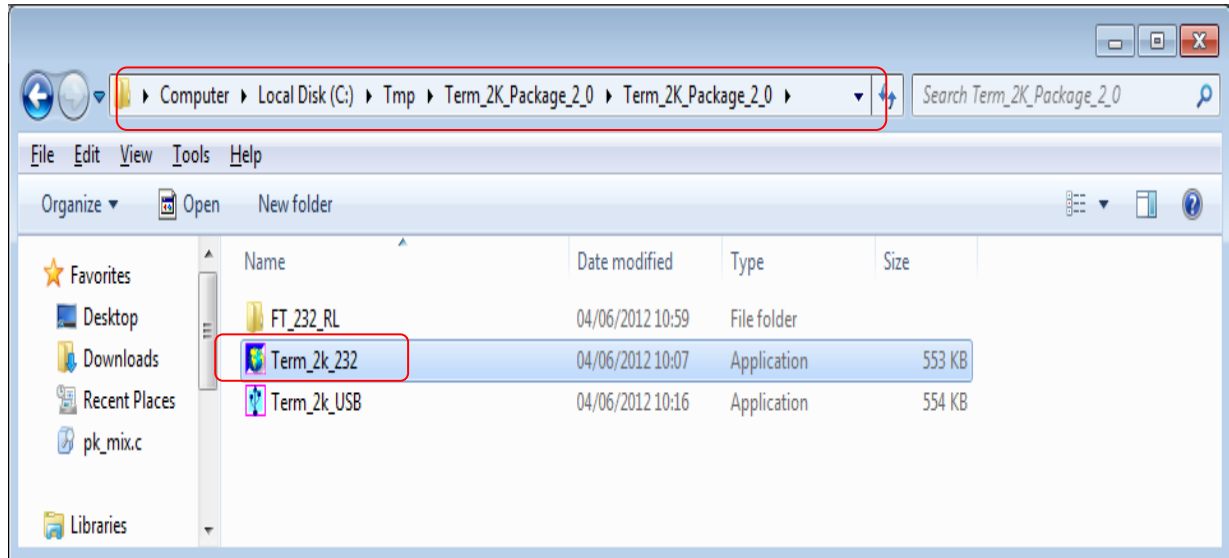

A suggestion is to create a link to the application and to place it over the Windows desktop.

A double-click using the left-button of the mouse on the application icon should give out a result as the one shown in the following picture:

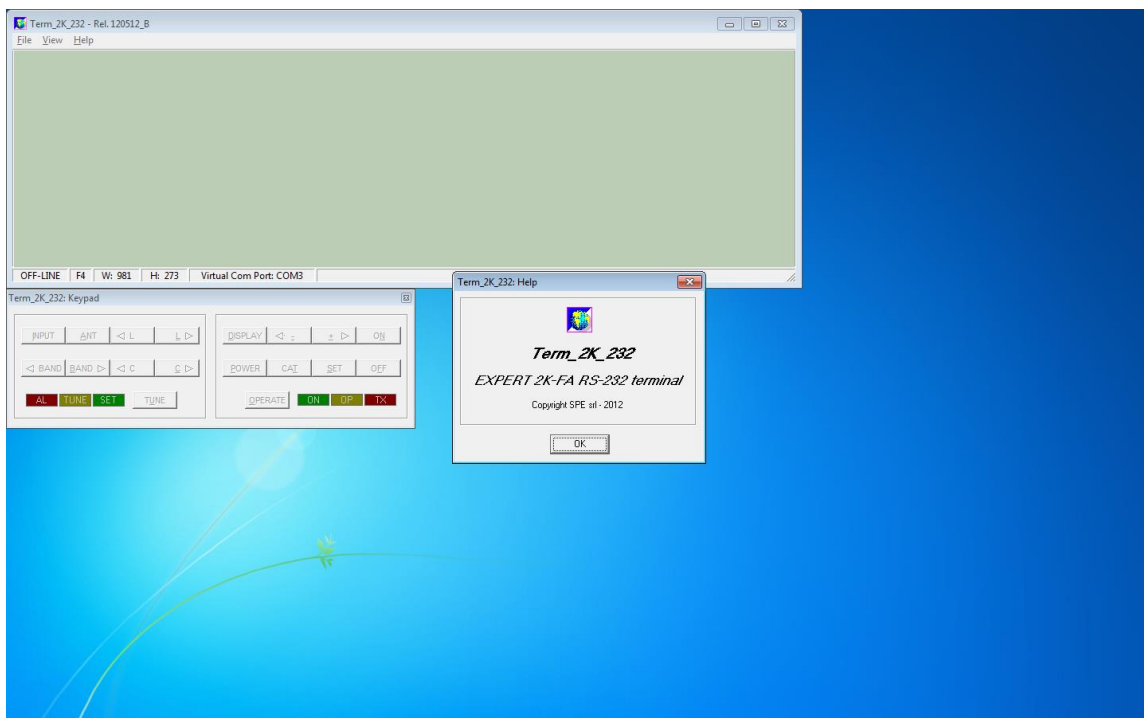

After then select File/Virtual Com Port setting.

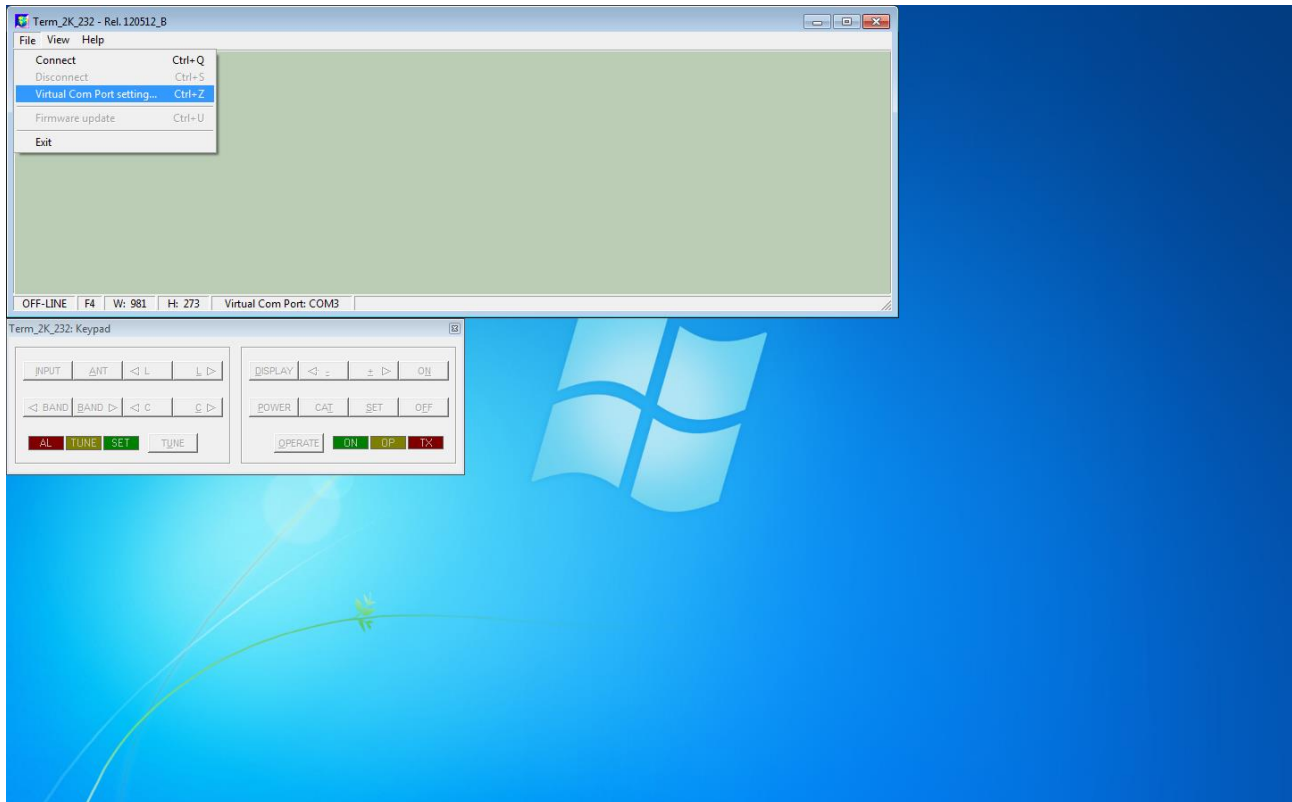

The above mentioned menu item makes it possible to access the following dialog box, which allows a direct setting of the desired COMx serial port for connecting the EXPERT 2K-FA.

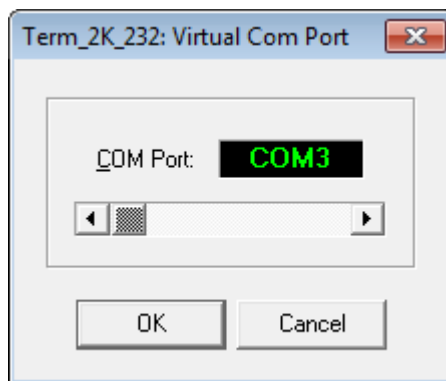

With all the serial resources connected go to Control Panel >>> Hardware and Sound >>> Device Manager and choose a serial COM listed in the HW configuration but not used by other applications.

In case USB-to-RS232 serial converters are being used, proceed as explained and check all the COM ports polled by the system.

To check a COM port identifier related to any given adapter, disconnect it and detect which COM item disappears from the proposed list after that configuration change. In case use that COM identifier to properly set the **Virtual Com Port** dialog box shown in the picture above..

The available selection range spans thru the [**COM1...COM256**] set, and it can be accessed using the framed slider placed above the OK and CANCEL keys.

All the other communication parameters are set as follows:

Baud-rate: 115200

Bit per character: 8

Parity check: No

and cannot be changed since they got programmed during the “SW installation” procedure.

As mentioned above, the application usage is still the same as in the USB interface version described earlier, while the display window backlight changes to ivory-white as shown in the picture below::

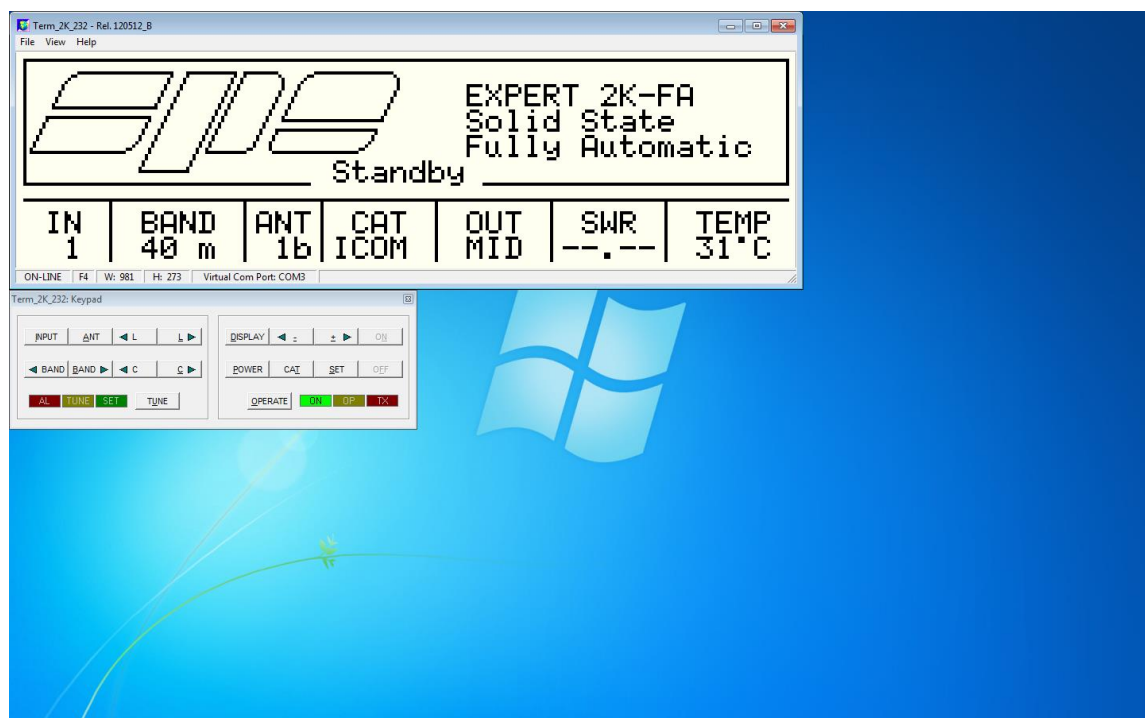

Using the RS 232 port becomes a necessity when the device needs to be remotized via the Internet, since most of the committed devices currently on the market don't implement a USB port feature.

To be noted that in this peculiar version [ON] and [OFF] keys got intentionally disabled. This is because switch-on and switch-off operations on the linear amplifier are directly driven by the remotized transceiver (see Section 13.2 “**REMOTE ON Connection**” on the **User's Manual**), while for the serial interface cable wiring consult **Section 13.5 “Port Connector”**.

20.4 Firmware update

A very useful function of **Term_2K_USB.exe** is the one which enables us to update the built-in firmware of the linear amplifier.

To update the linear amplifier it is needed a suitable **.PK1** firmware file, which must be downloaded from our website www.linear-amplifier.com and then stored into a proper working folder.

Switch the linear on, and keep it set to STANDBY mode during the firmware update job.

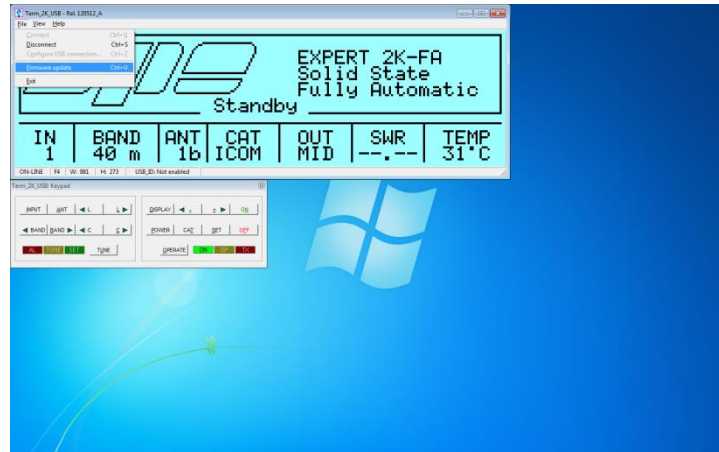

Under these conditions the **File\Firmware update** menu item is active and, upon its selection it sets the **EXPERT 2K-FA** to its firmware update mode (**FIRMWARE UPDATE PROCEDURE**).

After then a dialog box will pop-up, and the user is allowed to select a proper firmware package whose data must be sent to the linear amplifier to update all its embedded functions.

In the example of the picture below a firmware package file named **12_05_12_G.pk1** has been selected:

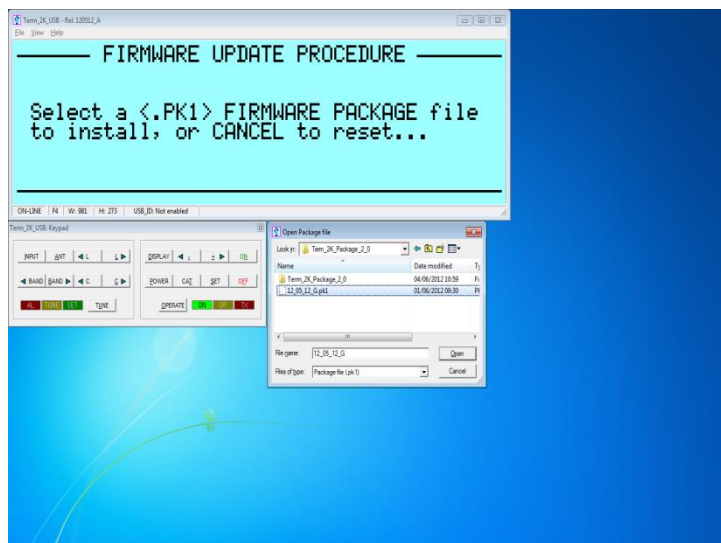

After a necessary confirmation by the user for validating the procedure, the **EXPERT 2K-FA** switches its display off and the overall control for updating actions gets transferred to **Term_2K_USB.exe** application

The main steps of firmware update procedure are the following ones:

1. Checking and validation of updating firmware package

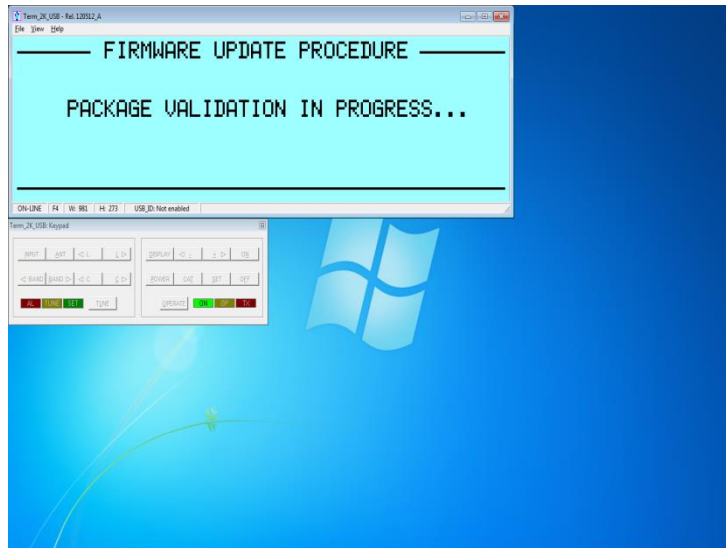

2. A physical data sending of the new firmware from the PC to the linear amplifier

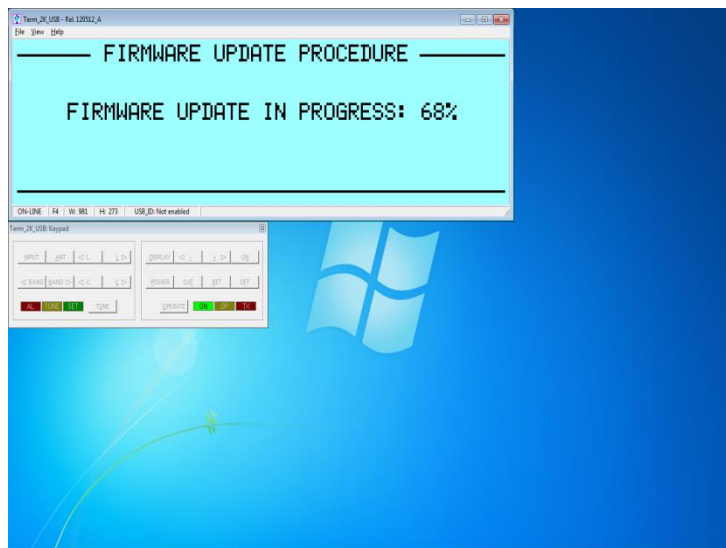

3. A final validation for the completed firmware update

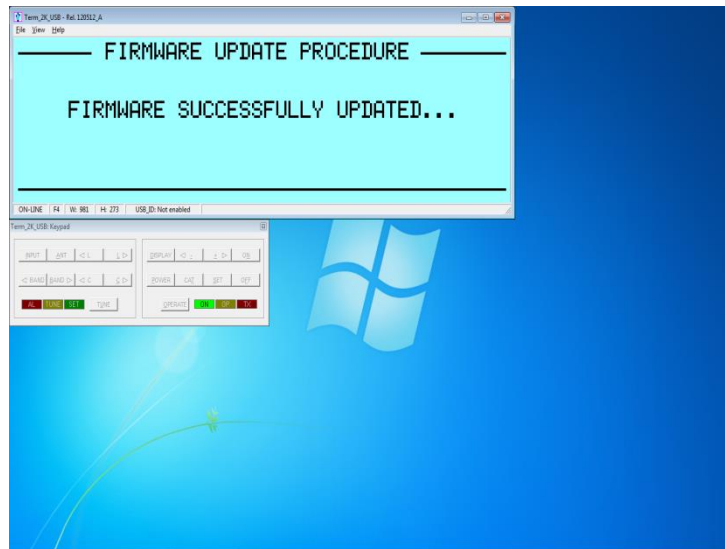

As a very last action after a successful firmware update, the linear amplifier performs a general auto-restart operation and, after then, a full control of the updated device is given back for both local and remote operations.

The user is then enabled to check the result of his firmware update operation directly on the LCD display (both real and virtual...) by pressing the **[CAT]** key twice.

This action will show

This operation will update the display report as shown below.

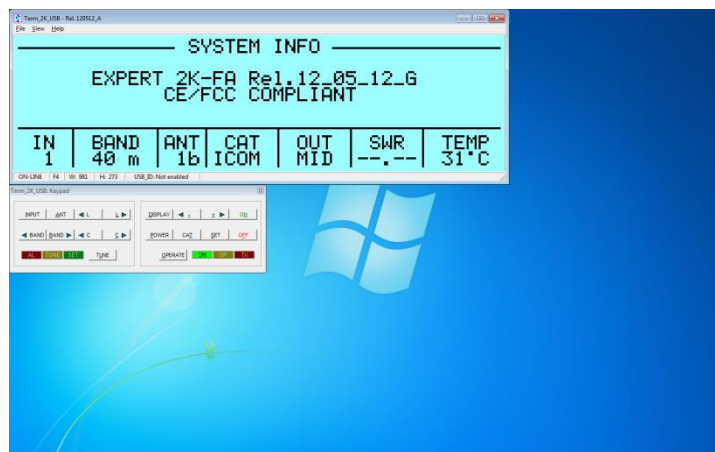

21. GENERAL RESTORE

A System General Restore can be performed by pressing **[INPUT]** and **[OFF]** keys together (for 1 second at least); this operation is only possible from the linear keyboard.

The linear will switch off with a proper system message.

Upon its later switch-on all its factory defaults will be restored.

22. WARRANTY TERMS

For a period of two (2) years from the invoice date, the Distributors warrant in the EU, at authorized laboratories, the free repair of manufacturing defects and the free replacement of defective components.

Each power MOS is guaranteed for the first 3 months and for a single replacement.

The warranty is not applicable in the cases specified below.

The Purchaser only has to pay all the shipping expenses in both directions.

Distributors outside the EU must comply with the current laws of the Country in which operate. If there is conflict with EU rules, they must post on their web site the relevant, modified “Warranty Terms”.

Customers should address requests for warranty service work to the Distributor/Dealer where they made their purchase.

As part of their reseller agreement with SPE, they are fully responsible for service support.

If the Distributor/Dealer has closed down and if he is not replaced, SPE will be directly responsible for warranty service at their factory in Rome. The shipping expenses to and from SPE will then be paid by the customer. Any repair requests to other dealers / repairer will be subject to specific direct negotiations between the customer and the dealer / repairer.

In order to not invalidate the warranty service, the original Purchaser must complete the warranty registration card, and send it to SPE within 30 days from the date of purchase. Unless otherwise agreed, the products will be delivered ex-works from the factory of the seller.

The delivery, even in the event of a return for repair, is understood done with the delivery of the goods to the carrier specified by the purchaser or, failing that, to the carrier chosen by SPE or the Distributor/Dealer.

The products will travel at the risk of the purchaser even if, at the request of the same one or for other causes, SPE should carry out transport or choose the carrier.

If the original Purchaser finds some defects after having received the equipment, he must immediately notify the Distributor/Dealer of the defects found by sending the completed REPAIR FORM. Replacement of the amplifier may be offered by SPE in exceptional circumstances only and at SPE's complete discretion. However, no replacement will be offered after 21 days of original purchase.

In case of a purchase of a used amplifier, in order to retain the warranty's validity, it is necessary to notify SPE of the following data:

Document for the second purchase (used)

Invoice for the original purchase

Serial number (s/n) of equipment

Replacement of equipment in these circumstances is not an option.

In any case the warranty period shall be as specified from the date of original purchase, and not from any subsequent purchase. However, the limitation for MOS remains as outlined above, ie. the warranty period for the LDMOS device/s is limited to three months only. If the LDMOS has been damaged due to incorrect usage, it is not covered under warranty.

Whenever the date of the first sale is not well specified, the date of shipping from SPE to the Distributor/Dealer will be considered the start of the warranty period.

The warranty does not apply either if the certificate of the first purchase (invoice) is missing, the s/n is undecipherable / falsified or to any defect that SPE determines is due to the following:

1. Improper maintenance or repair by persons not authorised by SPE to carry out such work, including the installation of parts or accessories that do not conform to the quality and specifications of the original parts.
2. Acts of nature such as lightning, storm & tempest, moisture or water intrusion, fire.
3. Misuse, abuse, neglect or improper installation, user's manual non-observance.
4. Carelessness, accidental or intentional damage.
5. In the manual of the transceiver used it is clearly written that it cannot be used with a solid state amplifier.

In addition and more specifically possible damage caused by incorrect usage such as:

- Exceeding power ratings of antennas, insufficient impedance transformers and insufficient baluns.
- RFI in the shack.
- Low gate isolation due to the spike of the transceiver.
- Repeated input overdriving alarms.
- Repeated high SWR alarms.

SPE warrants only manufacturing defects and defects in the materials used, NOT inherent and consequent damages.

It is mandatory, when sending SPE equipment to be repaired, to enclose:

- Invoice of the original purchase.
- Document of the second purchase (if any).

Particular agreements between retailer and Purchaser or particular obligations imposed in other countries are matters for the local retailer and not for SPE.

In the event of dispute Rome's court of competent jurisdiction will apply.

The Purchaser declares his acceptance of the above Warranty Terms.

SPE s.r.l.

Via di Monteverde, 33 00152 Rome (Italy)

Tel. +390658209429

Fax. +390658209647

E-mail: info@linear-amplifier.comWebsite: <http://www.linear-amplifier.com>