



SOCIETÀ PER L'ELETTRONICA s.r.l.

EXPERT 1.5K-FA TAURUS

**1.5KW SOLID STATE FULLY AUTOMATIC
DUAL LDMOS LINEAR AMPLIFIER**

USER MANUAL



Rev. 1.1

Index

IMPORTANT	4
HOW TO READ THIS MANUAL	5
PRECAUTIONS	5
UNPACKING.....	8
1. PANEL DESCRIPTION.....	9
1.1 Front Panel	9
1.2 Rear Panel	10
2. GENERAL INFORMATION	11
2.1 Power supply	11
2.2 Input / Output	11
2.3 ALC / RELAY / CAT	11
3. INTERCONNECTION WITH THE TRANSCEIVER.....	13
4. USE OF THE LINEAR AMPLIFIER	14
4.1 SO2R (Single Operator Two Radio).....	15
4.2 Band-Pass Filters Set “SPE BPF1”	17
4.3 QSK (Full Break-In) Operation	18
4.4 Tunable Antenna Control	19
4.5 Setting Up of an Antenna for Reception only	20
4.6 Can also be used on 5 MHz.....	21
4.7 Two Possible Sets of Antennas (Bank A or Bank B).....	22
4.8 Predistortion	22
5. EXTERNAL GROUND CONNECTION	23
6. ANTENNA.....	24
7. POWER SUPPLY (PSU)	25
8. TUNER (ATU).....	27
9. PROTECTIONS / ALARMS.....	29
10. PROGRAMMING.....	30
10.1 Ways to operate	30
11. INITIAL OPERATION OF THE AMPLIFIER	33
11.1 Initial Programming.....	33
11.2 Operating.....	36
Setting Driving Levels	36
12. CONNECTIONS.....	38
12.1 CAT 1 / CAT 2 Connectors	38
12.2 Icom.....	39
CAT CI-V Interface	39
12.3 Kenwood	42
CAT RS232 Interface	42
CAT 5V TTL Interface	42
12.4 Yaesu	43
CAT RS232 Interface	43
CAT 5V TTL Interface	43
12.5 BAND DATA Interface	44
12.6 Ten – Tec, Flex-Radio, Elecraft	44
CAT RS232 Interface	44
12.7 ALC with Flex-Radio (other SDR, Elecraft).....	45
12.8 Transceivers without CAT.....	46
13. OTHER CONNECTIONS.....	47
13.1 ALC, Relay Connections.....	47
13.2 Remote- ON Link.....	47
13.3 Connections TX-INH, / TX-INH.....	48
13.4 AUX Connector	50
13.5 PORT Connector.....	51
SteppIR cable:.....	51
Ultrabeam cable:	52
Serial connection to a standard PC RS-232 port for remoting use.....	52

14.	TRANSCEIVER CONTROLLED BY PC	53
14.1	Icom CI-V Interface.....	53
14.2	RS232 Interface.....	54
14.3	5V TTL Kenwood Interface.....	54
14.4	5V TTL Yaesu Interface.....	55
15.	USE OF THE USB / RS232 PORTS	56
15.1	LAN port	56
15.2	Remote Control	57
15.3	Download	57
16.	MAINTENANCE.....	58
17.	CHARACTERISTICS / SPECIFICATIONS.....	59
18.	DIAGNOSTICS.	61
18.1	Rapid SWR Increase... Check ANT.....	62
19.	TABLE	63
20.	APPENDIX 1 - REMOTE CONTROL.....	64
20.1	SW (Software) installation.	64
20.2	Term_1.5K_USB.exe usage	69
20.3	Term_1.5K_232.exe usage	79
	Remote ON/OFF using RS-232.	84
20.4	Firmware update.....	85
21.	GENERAL RESTORE	89
22.	WARRANTY TERMS	90
	REPAIR FORM	92

We congratulate you on the choice of the SPE EXPERT 1.5K-FA TAURUS solid state linear amplifier.

The addition of the double MOSFET guarantees great robustness, efficiency and linearity which, together with the implementation of new hardware and software processes including improved heat dissipation, allow digital modes to be treated at maximum power for very long times without problems.

Linearity at 1500 W

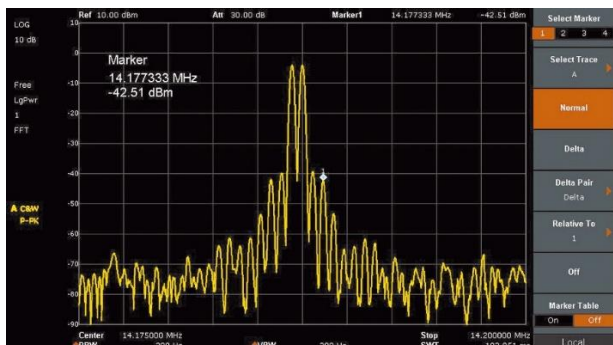

Two tone test at 20 m.

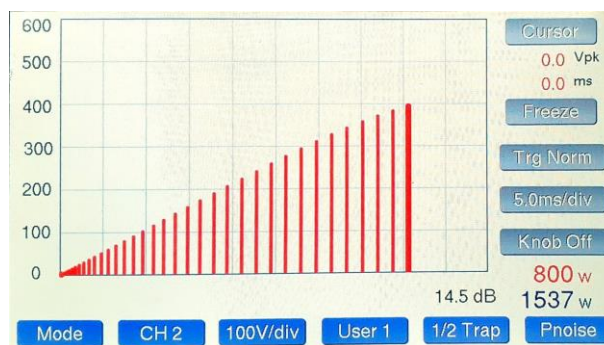

Trapezoid at 6 m.

This amplifier has built-in the power switching supply (100 – 255 VAC with PFC) and an Automatic Antenna Tuner capable of matching up to 5:1 at full power.

This amplifier is small, powerful and covers all the amateur bands from 1.8 to 50 MHz including the WARC bands and, where permitted, can be used on 5 MHz (60 meters). It is completely automatic and can be used remotely.

Weighing only 9.5 kg. (20.9 lbs), it is perfect for use in the shack and is superior to all other amplifiers for DXpeditions.

All operating conditions (frequency, antenna, tuner etc.) are controlled from your transceiver.

The operator only needs to move the frequency-tuning knob on the transceiver or clicking on the spot in the cluster.

Plus, it is possible to connect our amplifier to every transceiver available on the market, as it is extremely user-friendly, and is a product that is the best in its class.

IMPORTANT

Read this instruction manual carefully before operating your new linear amplifier.

Failure to follow these instructions will result in voiding the warranty.

The warranty terms are reported in chapter 22.

Please keep this manual, as it contains important safety and operating instructions for your SPE EXPERT 1.5K-FA TAURUS.

The manual is subject to changes and updates, therefore please check for a possible updated version on the website www.linear-amplifier.com.

The English language version is the official one.

HOW TO READ THIS MANUAL

This manual is divided into four main parts:

- **First part, from chapter 1 to chapter 9.**
The characteristics of the amplifier are described, it is essential to read this to fully understand this amplifier's potential capabilities that make this product unique.
- **Second part, from chapter 10 to chapter 11.**
Programming and startup of the amplifier is described step by step. Some advice is also given on how to manage various transmission modes.
- **Third part, from chapter 12 to chapter 16.**
This section details how to interface the amplifier with other equipment.
How to build cables, using USB/RS232 ports for remote control, downloads, etc.
- **Fourth part, chapter 20.**
Provides all the information for software management.

PRECAUTIONS

Explicit definitions

WORD	DEFINITION
 WARNING!	Risk of danger of fire or electric shock to people. Possible damage to the amplifier.
NOTE:	Serious problems if not observed. Danger of fire or electric shock for the operator, or damage to the equipment.

WARNING!

DO NOT disconnect any antenna from the amplifier during transmission.

This could cause a risk of electric shock RF burns or fire.

WARNING!

DO NOT modify the internal wiring of the amplifier. Any modifications will invalidate the warranty, and may reduce the performance of the linear amplifier or damage it.

WARNING!

Before using the linear amplifier, compare the value of voltage of your local AC mains supply system with those required by the amplifier.

WARNING!

DO NOT turn ON the linear amplifier unless it has been properly grounded through the GND conductor of the AC mains cord.

Do not disconnect this ground under any circumstances, this may lead to a risk of severe or fatal electric shock.

 **WARNING!**

DO NOT use an extension cord with the AC power cable unless it is correctly rated as there will be a risk of fire or electric shock. And could compromise the operation of the amplifier.

 **WARNING!**

DO NOT allow metallic objects or wires to enter inside the amplifier.

 **WARNING!**

DO NOT obstruct the cooling vents at both the sides, back and front of the amplifier. Ensure that no objects impede the correct operation of the fans

 **WARNING!**

DO NOT expose the linear amplifier to rain, snow or any liquids.

 **WARNING!**

DO NOT install the linear amplifier in a place without good ventilation. This could limit heat dissipation and the amplifier could be damaged.

 **WARNING!**

DO NOT touch the amplifier with damp or wet hands.
This could cause an electric shock.

Avoid opening the amplifier before you have disconnected it from the mains supply plus wait at least 2 minutes for the electrolytic capacitors to complete their discharge.

To clean the amplifier **DO NOT** use chemical agents like alcohol or benzene as the plastic surfaces could be damaged.

AVOID using the amplifier in areas with temperatures below 0° C (+32°F) or above +40°C (+104°F).

AVOID using the linear amplifier in locations that are very dusty, damp, have high humidity or that are in direct sunlight.

AVOID placing the linear amplifier against walls where the circulation of the air would be obstructed and the noise of the fans would be reflected toward the operator.

AVOID permitting children to play with the amplifier.

If you do not use the linear amplifier for a long time, set the back main switch [I/O] to the OFF position [O].

Information for Users on Collection and Disposal of Old Equipment and used Batteries.



These symbols on the products, packaging, and/or accompanying documents mean that used electrical and electronic products and batteries should not be mixed with general household waste.

For proper treatment, recovery and recycling of old products and used batteries, please take them to applicable collection points, in accordance with your national and local legislation.

This amplifier should only be operated by persons who have an appropriate radio transmitting license.

You should observe your license conditions while using it in accordance with national legislation (power, band, transmission mode etc.).

UNPACKING

Remove the packaging and carefully check the contents. Please look closely for the plastic pouch containing cables, fuses and connectors inside the box for your linear amplifier. It may be in the inside pocket of the canvas carrying bag.

If you find any damage or if there are any parts missing, contact your distributor / dealer immediately.

Keeping the shipping cartons and packaging materials for future transportation is recommended.

Accessories included in the carton

- a) Transport carry bag.
- b) Two cables with RCA (phono) connectors for ALC, RELAY links.
- c) One USB standard cable.
- d) Three connectors DB-15, 1 connector DB-9.
- e) One 20 A spare fuse.
- f) Spare air filter.
- g) Certificate of compliance and warranty form.

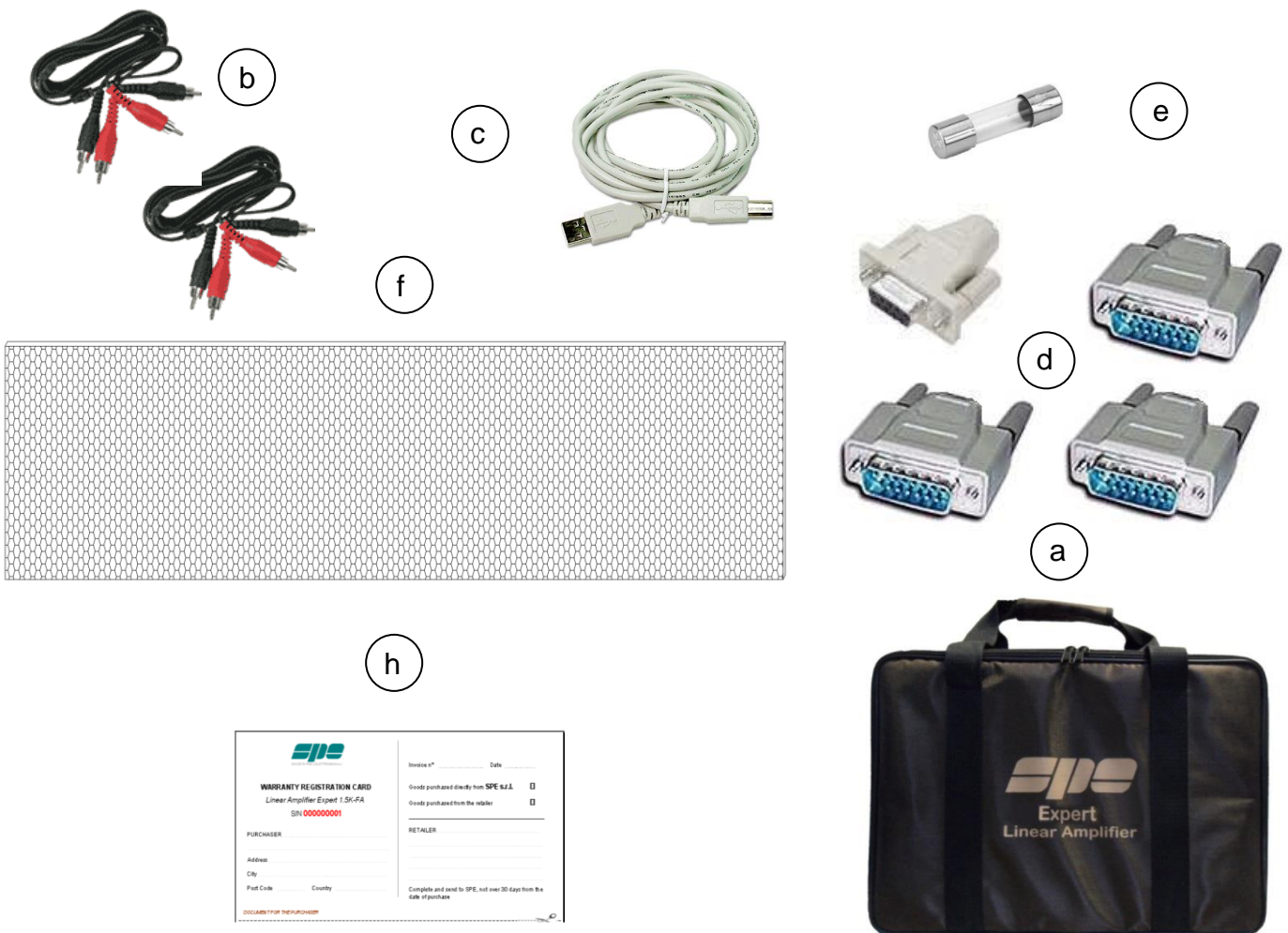

		Invoice n° _____ Date _____
WARRANTY REGISTRATION CARD Linear Amplifier Expert 1.5K-FA S/N: 000000001		Goods purchased directly from SPE s.r.l. <input type="checkbox"/> Goods purchased from the retailer <input type="checkbox"/>
PURCHASER		RETAILER
Address _____		_____
City _____		_____
Post Code _____ Country _____		_____
OCCASION FOR PURCHASE		Complete and send to SPE, not over 30 days from the date of purchase

1. PANEL DESCRIPTION

1.1 Front Panel

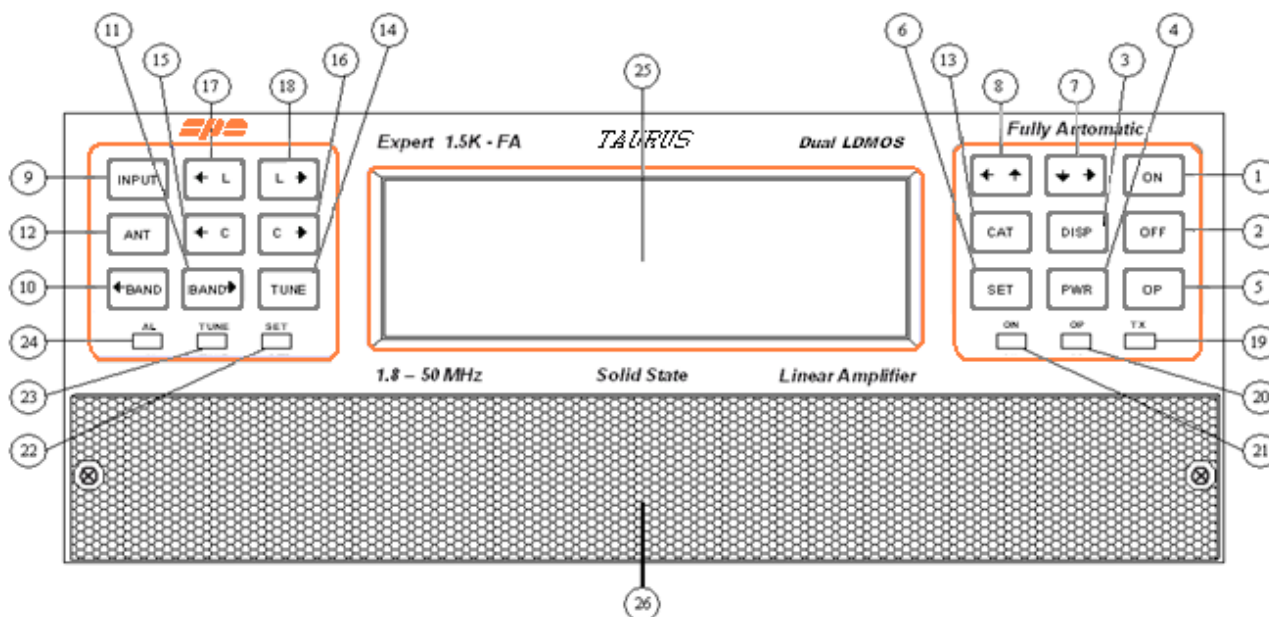

- | | |
|---------------------|---|
| 1) ON | turns on unit. |
| 2) OFF | turns off unit <u>when held down for three seconds</u> . |
| 3) DISPLAY | toggles between display pages. |
| 4) POWER | switches output power between "MAX / MID / LOW" |
| 5) OP | toggles back and forth between Standby/Operate modes. |
| 6) SET | used to program the amplifier. |
| 7) ▼▶ | used to program the amplifier. |
| 8) ◀▲ | used to program the amplifier. |
| 9) INPUT | selects one of the two inputs of the amplifier. |
| 10) ◀BAND | switches bands manually (downward in frequency). |
| 11) BAND▶ | switches bands manually (upward in frequency). |
| 12) ANT | switches the antennas when programmed for use. |
| 13) CAT | shows the current CAT interface setting. |
| 14) TUNE: | starts the automatic tuning process. |
| 15) ◀C | used for manual tuning. |
| 16) C▶ | used for manual tuning. |
| 17) ◀L | used for manual tuning. |
| 18) L▶ | used for manual tuning. |
| 19) TX | red LED, illuminates during transmission. |
| 20) OP | yellow LED, illuminates when the amplifier is in "Operate" state. |
| 21) ON | green LED, illuminates when the amplifier is "ON". |
| 22) SET | green LED, illuminates during programming. |
| 23) TUNE | yellow LED, illuminates during tuning. |
| 24) AL | red LED, illuminates when there is an alarm. |
| 25) LCD DISPLAY | |
| 26) AIR-FILTER GRID | |

Note: Pressing [CAT] key two times, will show the current firmware version.

1.2 Rear Panel

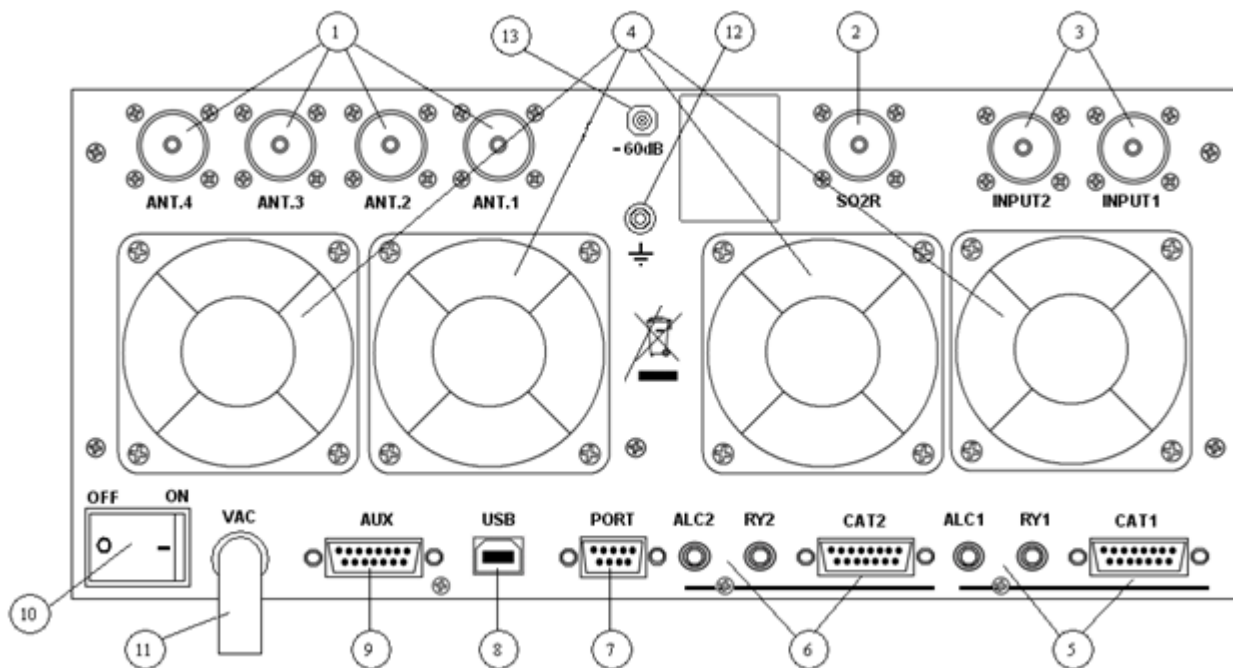

- | | |
|-----------|---|
| 1) ANT | connectors for four available antennas. |
| 2) SO2R | connector for SO2R operations. |
| 3) INPUT | connectors to connect two exciters. |
| 4) FANS | |
| 5) IN 1 | ALC, RELAY, CAT connectors for exciter 1. |
| 6) IN 2 | ALC, RELAY, CAT connectors for exciter 2. |
| 7) "PORT" | connector. |
| 8) "USB" | connector. |
| 9) "AUX" | connector. |
| 10) ON | main switch. |
| 11) AC | mains power cable. |
| 12) GND | ground connection. |
| 13) Pred. | -60dB attenuated tap. |

2. GENERAL INFORMATION

(Read the specific chapters for more details).

2.1 Power supply

The amplifier uses a switching power supply that will automatically adapt to any AC voltage supply that is between 100 and 255 Vac and is 50 or 60 Hz.

The main switch [I/O] is located on the rear panel.

In the [O] position all the internal circuitry is powered OFF, in the [I] position (red led ON) some internal voltages in the amp are now present allowing the operator to turn ON or turn OFF the linear amplifier in one of the following ways:

- a) Using the [ON]/[OFF] keys on the front panel.
- b) Applying / removing 9 to 15 VDC on pin (8) of the CAT connector (see note below).
- c) Using the USB port and the management software. This software can be downloaded from the website www.linear-amplifier.com .

Note: Almost all transceivers, when turned ON, will output 13.8 VDC. using this voltage, the linear amplifier can be automatically turned ON and OFF when the transceiver is turned ON and OFF.

Note: There is an "inline fuse" located inside the amplifier (remove the lower cover).

2.2 Input / Output

The linear amplifier has two inputs (INPUT 1, INPUT 2) to which you can connect one or two transceivers of any brand or type.

These inputs are selected with the [INPUT] key or automatically switched with the PTT of each transceiver.

The amplifier easily manages up to four antennas (ANT 1, ANT 2, ANT 3 and ANT 4).

The amplifier can be programmed to automatically select any of the four antenna ports.

The SO2R functionality is implemented by its dedicated connector, appropriately marked.

2.3 ALC / RELAY / CAT

There are two transceiver inputs (IN 1, IN 2), allowing two distinct transceivers to be connected at the same time.

ALC This is a negative voltage generated by the amplifier. It is used to limit the output power of the transceiver in order to prevent over-driving. (ALC allows maximum power of transceiver in STANDBY", then the proper drive power in "OPERATE"). In this way the drive power from the exciter will be regulated automatically without having to set it.

Plus it automatically adapts to your transceiver's voltage range (e.g. any range between 0 volts and negative 12 volts).

If the ALC port is not connected, it is mandatory to manually adjust the drive from the transceiver as happens in all other competitors.

The use of the ALC port is highly recommended.

Note: With this link, it is also possible when in the amplifier LOW power mode, with most transceivers, to use the arrows [▼▶] or [◀▲] to reduce the driving power to less than 5W in order to set the amplifier's output power within the country's limits.

RELAY **This essential port** allows the amplifier to be switched into the transmit state. To do that, the inner pin of the RCA phono connector must be switched to ground potential. This is normally done by the transceiver with either a “close-to-ground” relay, or an open-collector transistor. On the transceiver-side this link is often called SEND, PTT or TX GND. Refer to your transceiver manual for more details. Max current needed is only 2 mA or less.

CAT **This port is highly recommended**
Thanks to this port the linear amplifier will detect, while in the receive mode, the operating frequency of the transceiver and then automatically control changes of band, antenna and automatic antenna Tuner. All modern transceivers have CAT control options. In older models, often elementary analog or digital information is sent from the transceiver to the amplifier for band switching only. To facilitate any possible connection, there is also a very efficient frequency meter in the amplifier. The management of the band, the antennas and the Tuner is implemented in the Expert with one of the following choices:

- a) Through “CAT”, present in all recent transceivers. Band and sub-band are automatically selected by the receiving transceiver without the aid of the internal counter.
ABSOLUTELY RECOMMENDED SOLUTION AS IT IS THE MOST SAFE AND TECHNICALLY CORRECT.
- b) Using "BAND DATA", in this case the band is automatically set by the transceiver while the internal frequency meter will select only the sub-band during transmission.
- c) Through “NONE” in the absence of a suitable data connection with the transceiver. The fact that this condition does not require any connection might seem a simplification, in reality this choice is not recommended because band and sub-band will be selected by the internal frequency meter only during transmission.
Use this condition only if the choices a) and b) are NOT PRACTICAL.

GIVING THE POWER MANAGED, A DANGER CONDITIONS COULD BE VERIFIED, IN PARTICULAR BAND CHANGES IF DONE IN OPERATE. IT IS STRONGLY RECOMMENDED TO DO THIS IN STANDBY. NOT FOLLOWING THIS RECOMMENDATION WILL BE CONSIDERED "MISUSE" OF THE EQUIPMENT WITH CONSEQUENT LOSS OF WARRANTY (an indelible internal log records every condition).

In condition c) also avoid putting two transmitting antennas very close operating simultaneously on different bands, the resulting strong signals could generate undue band changes or SWR alarms.

Note: In some transceivers the “RELAY” and “CAT” signals are activated by a selection in the menu: in that case, please refer to their user’s manuals.

3. INTERCONNECTION WITH THE TRANSCEIVER

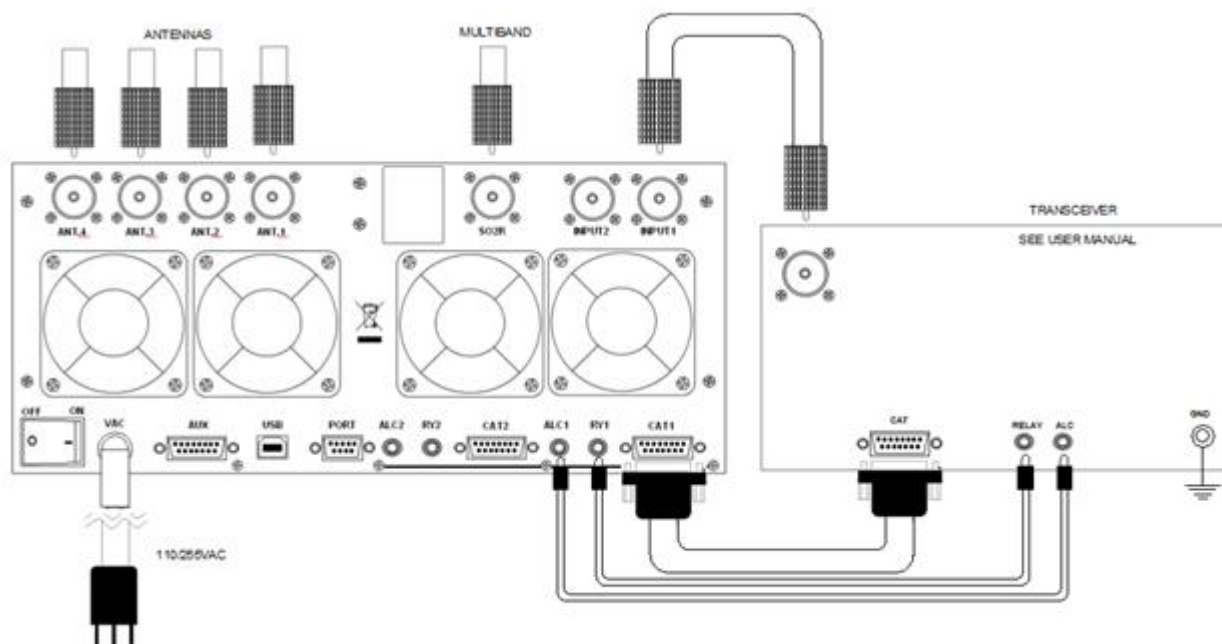

The diagram shows the connections with one transceiver only. To connect the second transceiver, repeat the same connections used for “IN 1”, now using the port “IN 2” connections.

For ALC and RELAY connections, use a shielded cable (supplied) with RCA phono connectors.

For CAT connection, this cable needs to be made by the owner, or purchased, for the many different transceivers available for use with the amplifier.

This cable may also include ALC, RELAY ON / OFF (read the “CAT CONNECTIONS” chapter of this manual).

For all other information about connecting a transceiver, please refer to the transceiver’s manual.

*Note: If the DB15 “CAT” connector is used for RELAY and ALC, **do not** also use the RELAY and ALC RCA phono connectors.*

4. USE OF THE LINEAR AMPLIFIER

Block diagram.

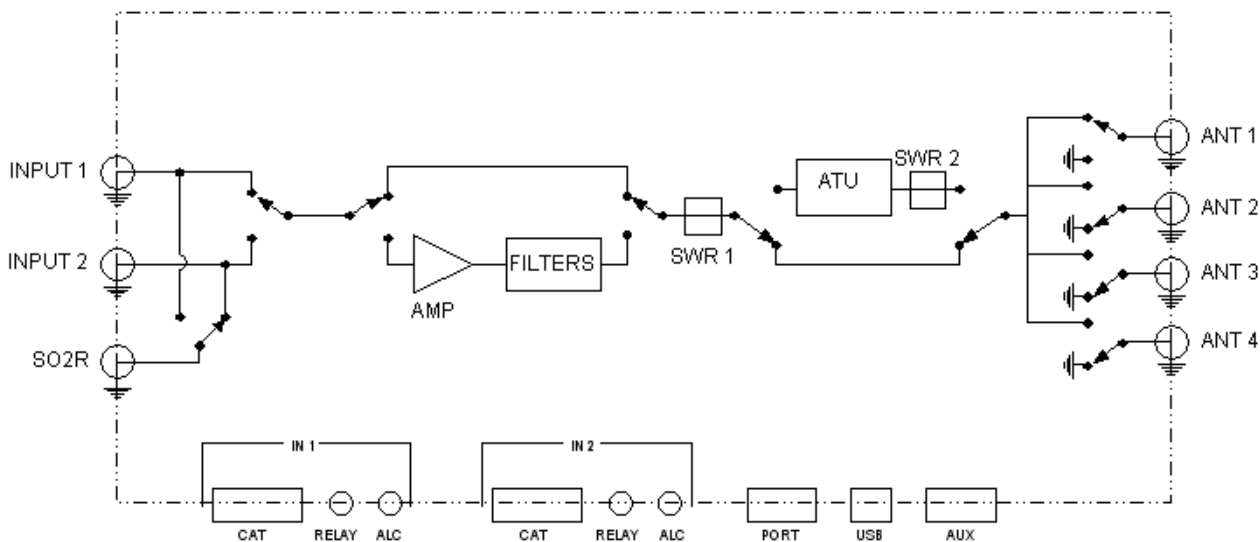

The position of the contacts, as shown in the diagram, is when the linear amplifier is in the OFF state.

The linear amplifier can be used in the following way:

- 1) OFF Only two direct connections are actuated:
 between INPUT 1 and ANT 1
 between INPUT 2 and SO2R
- 2) STANDBY All the functions are activated (band change, antenna change, tuner control) and the transmission is from the transceiver only.
- 3) OPERATE All the functions are activated and the transmission is using the linear amplifier.

Note: *Regulation of the exciter's power is automatically achieved through the ALC link. With the ALC connected, the amplifier input power in OPERATE mode is automatically adjusted to the correct driving level for the amplifier. In STANDBY the amplifier will pass the output power as set by its POWER OUTPUT control. Without the ALC connection, you have to manually adjust the exciter power to correctly drive the amplifier **in order to avoid damaging the amplifier.***

If you switch from MAX to MID or LOW without ALC connection, without previously reducing the driving power, the amplifier will go into protection for "OVER DRIVING".

Despite being protected, the amplifier is still exposed to risk with repeated "OVER DRIVING" conditions.

If you persist without investigating the causes, you will void the warranty.

4.1 SO2R (Single Operator Two Radio)

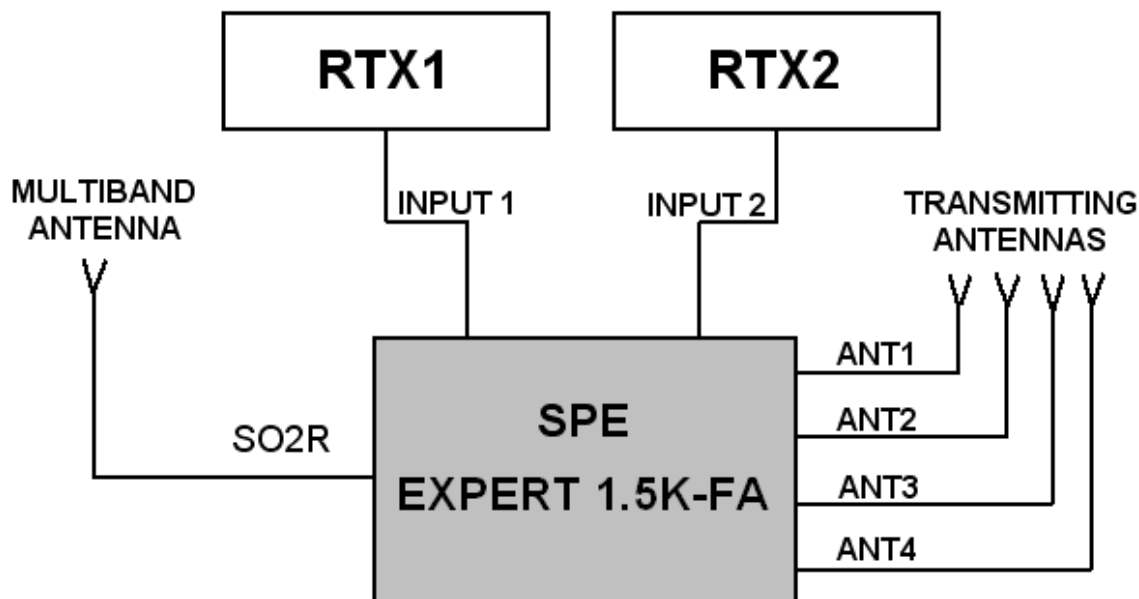

Operation of this kind is used during a contest in order to acquire a new multiplier, as quickly as possible.

The following connections are needed (see the diagram):

1. INPUT 1 connected to the first transceiver (RTX1).
2. INPUT 2 connected to the second transceiver (RTX2).
3. ANT 1/2/3/4 connected to the available antennas set.
4. SO2R connected to a multi-band antenna.

The operating mode could be the following:

If you are operating using RTX1 on a given band (e.g. 20m), the correct antenna (ANT 1/2/3/4) is automatically selected for listening and transmitting.

While RTX2 is connected to the multi-band antenna on the SO2R port, and is in the RX mode, on another band (e.g. 40m).

If, when operating on 20 m, a multiplier of interest is heard on RTX2, the only action needed is to push the PTT2 in order to connect RTX2 to the 40 m transmitting antenna.

At the same time RTX1 gets switched to the multiband antenna in order to receive on the 20 m band.

More generally, the appropriate antenna of the ANT 1/2/3/4 / park is associated with the transmitting transceiver, while the multiband will pass to the other transceiver for reception only

Instead of the multiband antenna it is possible to use one of the same antennas of the ANT 1/2/3/4 park for reception. This possibility is offered by the use of the "AM-01 REMOTE SWITCH" external unit which also **has the ability to extend the number of usable antennas from 4 to 6** according to the following figure.

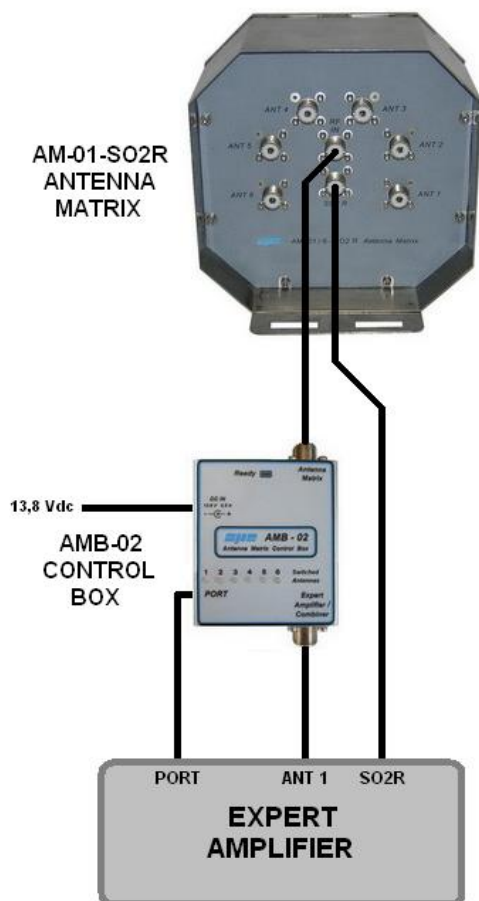

This unit is not simply a "remote antenna switch" for 6 antennas in SO2R mode, it also has the ability to become a 1 x 6 matrix, perfect for simply remoting up to 6 antennas (in this case the SO2R cable is not needed) .

This solution does not require any additional cable since the antenna coaxial cable is also used to send the commands and to power the switch.

The control signals are provided by the Expert 1.5K-FA according to the table that already exists inside the linear that associates with the maximum flexibility of the antennas to the bands.

For setting, see chapter 10 "Programming" and read the AMB-01 user manual.

Note: ATTENTION, the insulation between the transmitting antenna and the receiving antenna must be high and therefore well studied.

This can be achieved by conveniently arranging the antennas and using suitable Band Filters or Stubs.

SPE is not responsible for any damage resulting from the equipment.

4.2 Band-Pass Filters Set "SPE BPF1"

To increase the isolation between the transmitting and the receiving antenna, SPE has under design an optional unit called "SPE BPF1" which must be placed between RTX1 and INPUT1 or RTX2 and INPUT 2 of the linear.

The unit is controlled and powered from the AUX port.

(Contact the manufacturer or your distributor for availability).

The AUX port also provides all the information necessary to control a similar unit of *another manufacturer*.

This unit automatically enables the following features:

- DXpedition, Contest Multi / Multi

In this situation the amplifier is connected to a single transceiver (INPUT 1 or INPUT 2). "SPE BPF1" automatically selects the filter on the band to be used in the input where the transceiver is connected, while the other unrelated input is left unused.

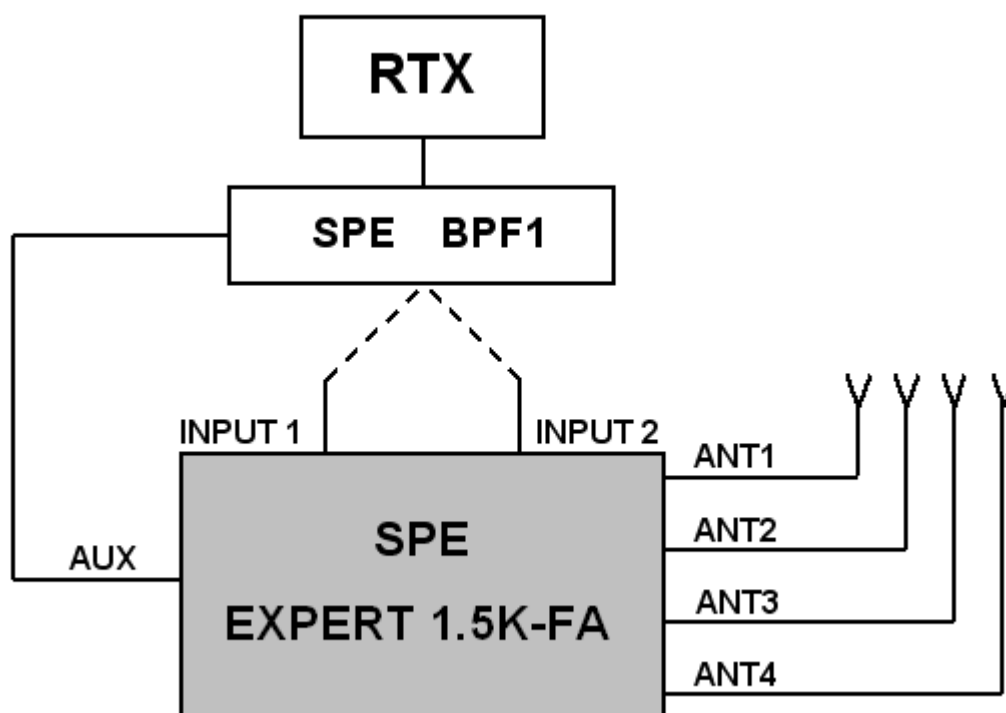

- Contest SO2R.

In this case the amplifier is connected to two transceivers and two "SPE BPF1" in order to automatically select the right filters in the output of both the transceivers.

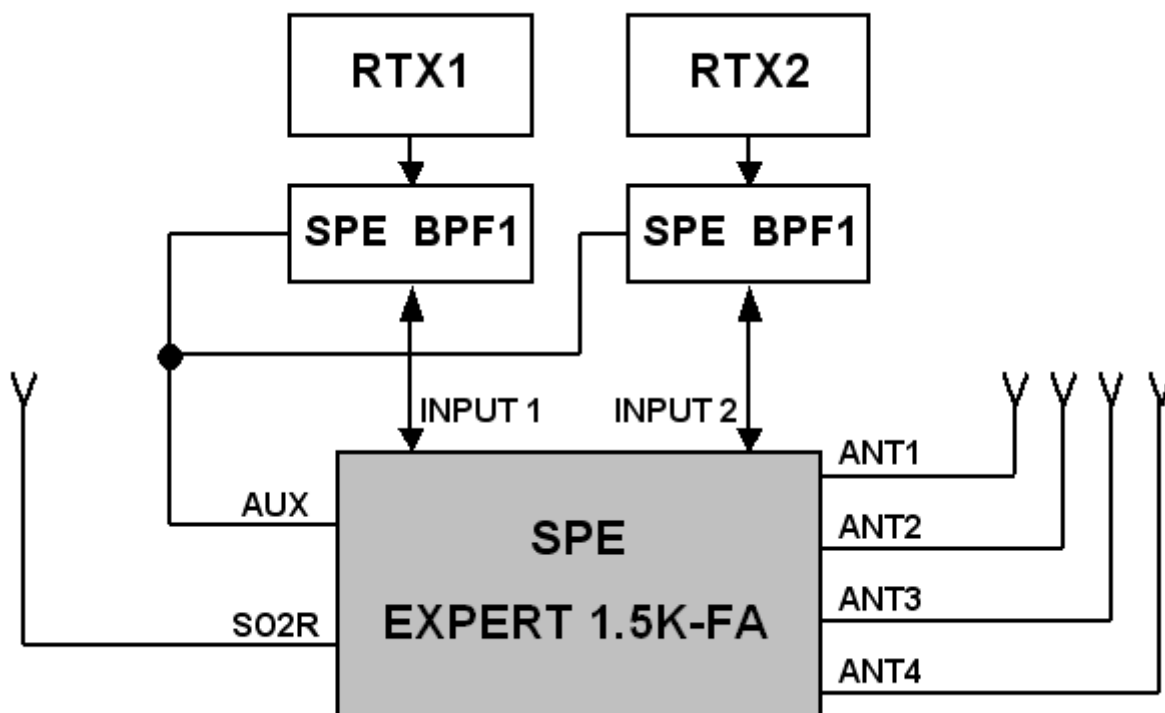

These features can be possible, as well, with the simultaneous use of the unit "AMB-01" (see item 4.1).

To ensure the proper functionality of these options, CAT connector control is mandatory.

4.3 QSK (Full Break-In) Operation

The Expert 1.5K-FA also allows QSK (FULL BREAK-IN) operation. Thanks to the correct control used on the RX / TX switching relays, any possibility of "hot switching" is avoided.

This feature is compatible with all modern transceivers, in fact the minimum delay required before a transmission is usually less than 6 msec. (check the manual of the transceiver).

In the case (and it is very remote) of minor delay needed, you can use the link TX - INH (see "CAT" paragraph).

Special very reliable, "noiseless", with high mechanical performance, gold plated relays are used so that the "vacuum relays" option is no longer required.

4.4 Tunable Antenna Control

The use of tunable antennas (SteppIR, Ultrabeam) is becoming popular.

These antennas vary the physical dimensions of the elements according to the operating frequency in order to ensure a perfect resonance.

The Expert 1.5K-FA, through the dedicated "PORT" socket linked to the antenna controller, allows automatic control by tracking the tuning knob changes.

This dedicated link makes the following advantages possible:

- Simplification of wiring, such as the complication of adding additional wiring to the CAT connector is no longer necessary.
- Compatibility with all types of CAT: The Expert 1.5K-FA converts the CAT protocol, so two different transceivers (CATs) can be used simultaneously with the same controller without any modification of the wiring.
- Thanks to the frequency counter inside the linear, the antenna can be controlled also without the use of CAT (CAT NONE).

All of the automatic features of the linear are ensured even in the most complex configurations.

Antennas of all kinds can be connected to the "ANT" PORTS and the Expert 1.5K-FA will choose the antennas according to the set-up and will manage them according to their characteristics.

The CAT is recommended, however, if the transceiver does not have the CAT or if it only has the "Band Data", the Expert 1.5K-FA will continue to drive the antenna with the frequency measured by the counter (data collected after the first transmission) .

The simplest possible configuration is a single tunable antenna according to the following diagram

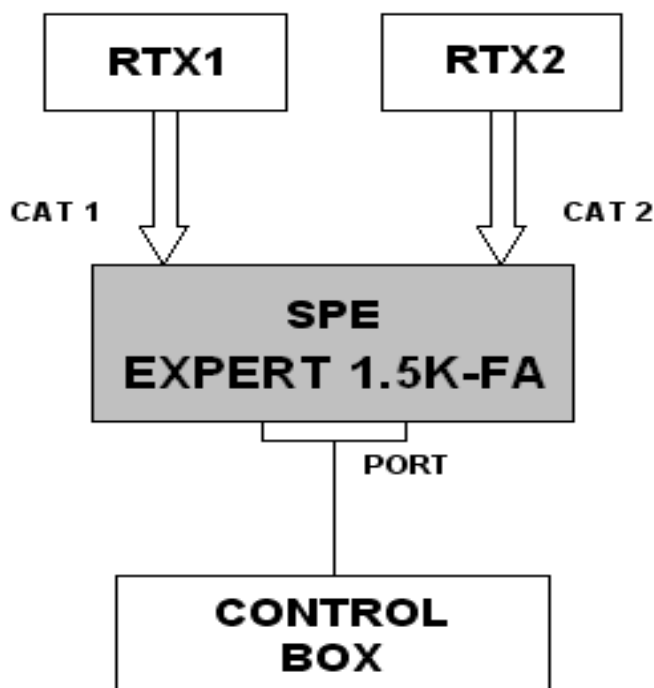

The link is configurable for any position (ANT 1,2,3,4) you want use.

To select a tunable antenna, refer to the "TUN ANT" item on the main menu. After selection, on the display, next to the number of the antenna in use a "t" will appear. In this case the ATU will be bypassed.

Set "Kenwood" in the control box as the communication protocol used, the speed of the communication is "owner settable."
For the connection cable, refer to chapter 13.5.

4.5 Setting Up of an Antenna for Reception only

In some cases it may be necessary to transmit with one antenna and receive with a more appropriate one.

A unique feature allows the Expert 1.5K-FA to have a very flexible management of the available antennas.

To select a receiving antenna, refer to the "RX ANT" item on the main menu. One of the following functions can be selected for each antenna:

- **RTX:** this is the "default" condition, an antenna marked RTX can be used for both transmission and reception regardless of whether it is in the first or second column in the "ANTENNA" menu item.
- **RX Also:** an antenna marked RX Also if, in the "ANTENNA" menu item, it is placed in the first column it behaves like a normal RTX, if it is placed in the second column it provides reception after the antenna selected in the first column has transmitted.
- **RX Only:** an antenna marked RX Only is an antenna suitable for reception only (e.g. Beverage) it can be inserted in the first or second column, the important thing is that an RTX is present in the other column. Since with linear OFF the INPUT1 is connected directly to ANT1, to avoid the danger of transmitting when the linear is off with a receive-only antenna, it is not possible to select ANT1 as RX Only.

The program admits only one RX Only.

In the "ANTENNA" menu item, in the last two cases, an "r" will appear next to the number of the selected antenna (e.g. 3r). On the main screen, the indication of the receiving antenna is placed above the transmission one.

QSK does not recommend this feature for timing reasons.

As an example, the screens are shown in the case of using ANT1 as "RX Also".

“RX ANT setting”

```

- RX-ALSO/RX-ONLY ANTENNA ON BANK "B" -
  RX-ALSO
  ANT2: RTX
  ANT3: RTX
  ANT4: RTX          SAVE
----- SET ANT 1 AS RX
[4^][v>]:SELECT          [SET]:CHANGE

```

“ANTENNA setting”

```

----- SET ANTENNA ON BANK "B" -----
160 m: NO NO | 30 m: NO NO | 12 m: 2 NO
 80 m: 3 1r | 20 m: 1 NO | 10 m: 1 NO
 60 m: NO NO | 17 m: 2 NO | 6 m: 4 NO
 40 m: 3 1r | 15 m: 1 NO
                                           SAVE
----- SET 1st ANTENNA ON 20m BAND -----
[4^][v>]:SEL [TUNE]:ATU Y/N [SET]:CHANGE

```

“OPERATE page”

```

PA OUT 0 250 500 750 1000          0 W PeP
I PA    0 12.5 25 37.5 50          0.0 A
-----
IN | BAND | ANT | BNK | CAT | OUT | SWR | TEMP
 1 | 80m  | 3  | B   | ICOM | MID | --.-- | 24°C

```

If you want to exclude the receiving antenna at the moment and also receive with the antenna with which it was transmitted, just press the [ANT] button on the front panel.

If using a preamplifier it is strongly suggested to use a sequencer.

4.6 Can also be used on 5 MHz

Where permitted, the Expert 1.5K-FA can provide the full power on 5 MHz (60 m.). It should be noted that, although permitted, this band may have power limitation, follow the laws of the country in which you operates.

4.7 Two Possible Sets of Antennas (Bank A or Bank B)

The Expert 1.5K-FA amplifier is equipped with two different memory banks, "Bank A" and "Bank B".

If you have two different QTH's, then they would certainly have two different antenna setups.

Therefore it would be useful to automatically recall data from one setup to the other with no need to adjust the configuration and the subsequent ATU matching every time.

This feature is also particularly useful if you participate in a DXpedition.

If one of the memory banks is set as your home station, upon returning, just recall the appropriate memory bank.

For setting, see chapter 11.1 "Initial Programming", refer to the "CONFIG" item on the main menu.

4.8 Predistortion

On the rear panel there is an SMA connector where the transmitted signal is attenuated by 60 dB (50 ohms).

This signal can be used to connect an SDR transceiver with appropriate software in order to improve the IMD of the transmitted signal by 25 dBc or higher (depending on the software).

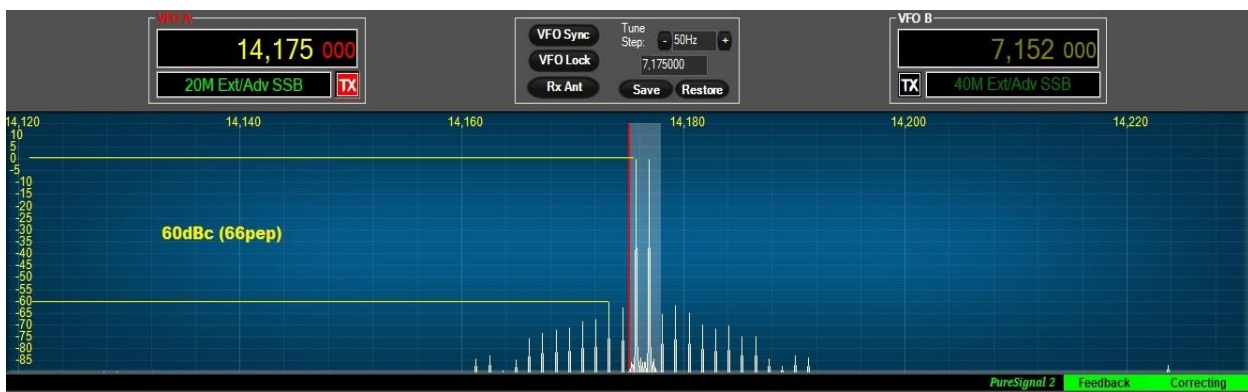

This result was obtained with an SDR transceiver currently available on the market.

An exceptional IMD of -66dB has been obtained since in the EIA standard the amplitude of the distortion products is referenced to the peak envelope power, which is 6 dB higher in power than the represented by one of the two tones.

5. EXTERNAL GROUND CONNECTION

To reduce TVI, BCI and other RF problems in the shack, it is best to connect the amplifier to a good RF ground. (Note that an RF ground is different to an electrical ground which is necessary for the prevention of electrical shock.)

The inductance of such a connection needs to be low, so the connection to ground should be as short and direct as possible.

Large-section copper conductors should be used for this purpose.

Terminating the earth connection with a small metal plate is suggested.

The best solution is to have several ground stakes, driven into the ground and these ground stakes need also to be tied to your main grounds.

Good results can often be achieved by using correct earthing clamps, connected to the main water supply pipe (attention, many water pipes are now in plastic).

DO NOT use central heating pipe work.

AVOID the electric circuit ground of the building (to be used for 50/60 Hz safety only).



WARNING! DO NOT connect to gas pipes as there will be a danger of explosion.

6. ANTENNA

Because this is a high-power amplifier, it is necessary to use properly rated antennas, connectors and feed line cables.

Much care must be paid to the use of antennas with traps, BALUNs and impedance transformers insufficient so that often, after continuous use at high power, these elements exceed the Curie temperature degenerating irreversibly, resulting in a dangerous increase in SWR during each transmission which could lead the linear to damage.

This dangerous situation is often not perceived by the operator because a normal measure of SWR is made when a balun and antenna are not under stress or have cooled down.

Ensure that your baluns, impedance transformers or traps are appropriately rated !

A unique feature of this linear is that, measurements are made not only of the SWR after the band pass filter matching, but also of the SWR of the system antenna and cable. This allows the operator to always evaluate their antenna system despite the matching and the power applied.

With the internal ATU, the amplifier is able to overcome mismatches up to 5:1 at full power.

Be aware that, with the tuner, the PA is matched but with a high VSWR the cable is mismatched and there can be consequent loss of power, heating and high voltages present, therefore always try to use resonant antennas, avoiding non-resonant antennas if possible for the reasons explained previously (insufficient impedance transformers).

Always operate with the best possible matching because, despite the amplifier's protection against high SWR, continuous use into a mismatched load (a bit lower than the protection threshold) may lead to damage.

In the case of repeated "SWR EXCEEDING LIMITS" alarms while being protected, the amplifier is still exposed to risk.

If you persist without investigating the causes, thus causing a failure, you will lose the warranty.

It is suggested that suitable static protection be given to antenna feeder cables.

The software allows you to select up to two antennas for the same band.

Note: For a mismatch from 1.7:1 to 2:1 there is an alarm, above 2:1 the amplifier is switched to STANDBY.

For setting, see chapter 10 "Programming", refer to the "ANTENNA" item on the main menu.

7. POWER SUPPLY (PSU)

The power supply of the SPE Expert 1.5K-FA, unique in its category, is switching with a PFC (Power Factor Correction) that allows a drastic reduction of the harmonic components in the mains in accordance with IEC555-2, that consists of two sources.

The first powers all the electronic circuits, with the PA being excluded.

The second feeds only the PA. Its output voltage is selected based on the required output power level.

This design was adopted as it provides maximum efficiency and therefore less heat to dissipate.

Every precaution has been adopted to eliminate any disturbances produced by switching, the figure shows the spectrum analysis in the 10 m band.

As you can see, the result is practically the limit of the analyzer.

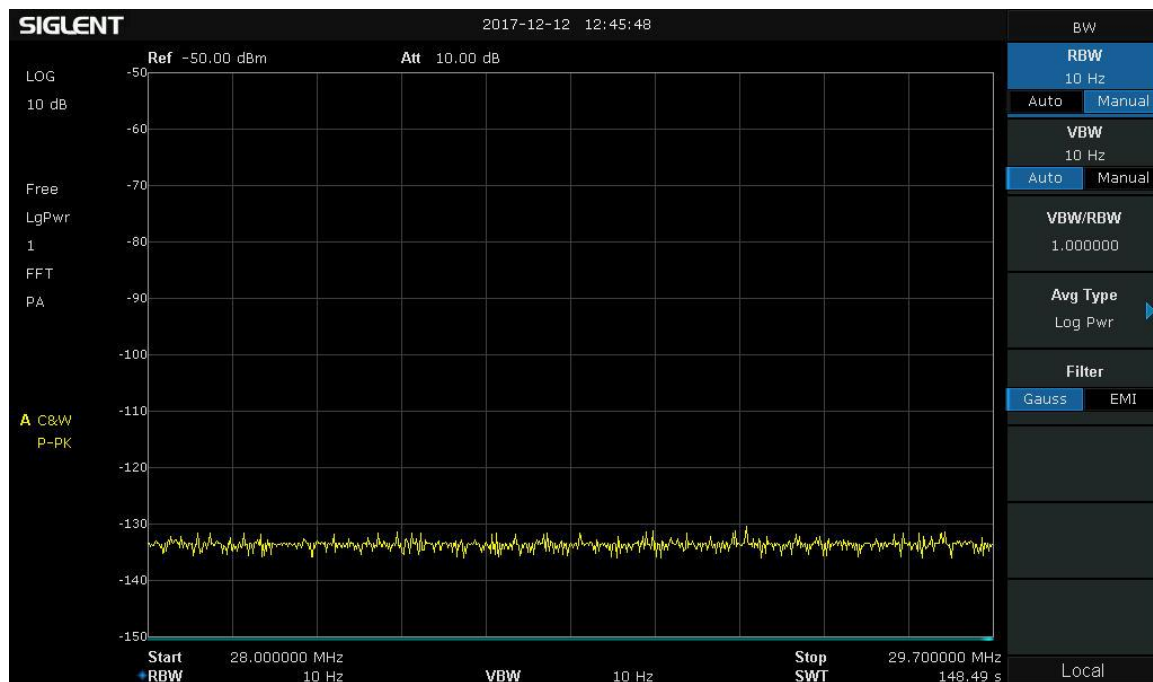

The power supply meets the following applicable standards: UL60950-1, TUV EN60950-1, EN55022, EN61000-3-2,-3, EN61000-4-2,3,4,5,6,8,11; ENV50204, EN5502.

Since the amplifier is sold all over the world, the power cord does not come with any mains plug. Some SPE distributors will fit the plug appropriate to your domestic supply network prior to purchase. Should it be necessary to rewire the plug due to relocation in a different country, please ask for advice from a qualified electrician.

To fit the plug (20 A minimum rating below 120V AC, 10A minimum rating above 120V AC) proceed according with the following fig.

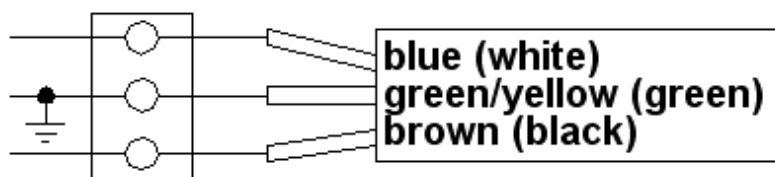

You should observe all precautions in accordance with national legislation.

The amplifier is supplied by a power supply that automatically adapts between **100 and 255 VAC, 47-63 Hz**.

In some particular cases, mains that are 100 to 120 VAC, the power in MAX may be reduced somewhat.

In the case of a "FATAL" alarm, the power supply is locked. To restore the linear, switch it to OFF for about 30 seconds, via the rear switch, then back ON.

If the alarm persists, contact the Distributor.

Note: In some conditions it is possibly to perceive a small "hiss" coming from the power supply.

This sound should not worry you as it is the action of the PFC, essential circuit mandatory in the CE area, to optimize the efficiency of the power supply and to reduce the introduction into the mains of noise generated by the request for high power.

The PFC takes into account not only instantaneous load requests but also the momentary conditions of the mains itself.

8. TUNER (ATU)

The amplifier has an automatic tuner that handles load mismatches up to **5:1** VSWR (2.5:1 for 6 m).

The amplifier is supplied by default with all bands in bypass, a “b” is present next to the selected antenna.

To remove the bypass go to [SET] >> “ANTENNA” and press the [TUNE] key.

To return to the bypass press the [TUNE] key again.

The amplifier contains a look-up table with all the permitted bands.

For tuner management, antenna data and other working data are stored.

Every band has a sub-band set, and for each of those, data related to the antenna and auto-ATU tuning is stored.

The CAT and the frequency counter detect the operating frequency and the correct sub-band.

Due to the stored data, the tuner and the antenna are automatically set correctly.

As described earlier (see item 4.6), the amplifier has two different memory banks.

It is possible to use the two different presets when the amplifier operates at two different locations.

Furthermore, table-driven management is useful to inhibit operations of the amplifier, for example, when an antenna for a particular band is not available.

All auto-tuner functions remain operational in standby, while using the transceiver only.

Setting of the match data to write to the tables is performed automatically by pressing the [TUNE] key.

The system will then find the correct match for minimum SWR.

In some cases (low bands) it may be useful to repeat the above operation.

To achieve a better match than that achieved with the automatic tune procedure (which is rather unlikely) it is possible to set the tuning manually by using the keys [◀C], [C▶], [◀L], [L▶].

When a manual tuning is performed, it is possible to read the tuning value, the working frequency and the associated sub-band on the appropriate screen page.

Both types of tuning must always be implemented in the “STANDBY” mode.

Before starting a matching process, the tuner measures the SWR of the system cable / antenna. If it is greater than 5:1, the procedure does not begin and an alarm is displayed.

It is possible to bypass the tuner with a specific command, in order to use an external tuner.

NEVER USE THE INTERNAL TUNER IN SERIES WITH AN EXTERNAL ONE, IF YOU WANT TO USE AN EXTERNAL TUNER, FIRST DISABLE THE INTERNAL ATU.

USING THE EXTERNAL TUNER ALWAYS MAKE THE MATCHING IN “STANDBY” NEVER IN “OPERATE” USING ONLY THE RF OF THE TRANSCEIVER (with its ATU excluded).

IF DONE IN “OPERATE” THE HIGH POWER AND THE SUDDEN ABRUPT MISADJUSTMENTS DURING THE MATCHING PROCESS COULD SERIOUSLY DAMAGE THE PA OF THE AMPLIFIER.

FOR THIS REASON IT IS RECOMMENDED TO USE THE INTERNAL TUNER BECAUSE IT GUARANTEES THE NECESSARY AUTOMATION EVEN WITH A HIGH SWR RATIO (5: 1).

NOT FOLLOWING THESE RECOMMENDATIONS WILL BE CONSIDERED "MISUSE" OF THE EQUIPMENT WITH CONSEQUENT LOSS OF WARRANTY.

The internal tuner may be bypassed as follows:

- Totally.
- For single band.
- For a single band and a specific antenna.

It is always automatically bypassed:

- With a "receiving only" antenna (If set in programming).
- With a tunable antenna (If set in programming).

Note: The tuner, like all analog circuits, introduces a loss (0.8 dB max.) that may vary with matching conditions.

The power meter of the amplifier does not show this loss as the power is measured at the tuner input where the load resistance is always constant (50 ohm).

Do not expect external power meters to match the displayed power.

It should be understood that an external measure of power might be lower depending on the matching attenuation.

Note: Sometimes, especially in the low or high frequency bands, even if the cable/antenna mismatches are lower than the declared maximum, it is not possible to reach an acceptable match.

This is technically explainable with the help of Smith's chart where it appears that the values of R and X for a certain SWR values are infinite, some of which are not technically practicable for the ATU.

This is evident by going into the MANUAL MODE and verifying that C and/or L are at the ends of their possible values.

Note: ATTENTION: When the amplifier is either in the "STANDBY" or in the "OPERATE" mode, always disable the automatic tuner in your transceiver.

Note: On the display, next to the number of the antenna in use, the following indications may appear.

Below identifies those meanings (see specific chapters):

"b" = ATU bypassed.

"t" = tunable antenna.

"r" = receiving antenna.

9. PROTECTIONS / ALARMS

The SPE EXPERT 1.5K-FA has a sophisticated protection system that constantly monitors and controls the amplifier's most important parameters.

The main parameters are:

Temperature of the heatsink; max. / min. voltage on the PA; max. PA current; SWR; reflected power; max voltage RF in the tuner; input power.

The protection system is carried out in two different ways:

- 1) Through hardware circuits to ensure minimum intervention time.
- 2) Through software, with a combined action of the two CPU's, to ensure maximum precision.

These two results get constantly compared; every difference produces a protection trip and a consequent alarm.

There are three types of protections/alarms:

- a) **SIMPLE** This is the most common case. An acoustic warning beep sounds, but no operator intervention is required, as the control system automatically restores the correct operating conditions.
- b) **SERIOUS** When automatic system recovery is not possible (e.g. the temperature climbs over the limits due to obstruction of the fans, SWR is too high, etc.). In this case the amplifier switches back to the standby mode and the alarm message gets stored. Normally transmission will continue with the exciter only.
- c) **FATAL** If the amplifier is in the (b) state, but one CPU has a fault or it can't continue operating or some fault appears in the power-supply module, then the amplifier will be turned OFF with no further warning. Obviously nothing can be written in the log. To restart the amplifier, the main switch in the rear panel has to be switched to [O], and then to the [I] position.

Note: It is possible to read the alarm history in the standby mode using [SET] and then [ALARMS LOG] keys. To empty the alarm stack press [TUNE] and [OPERATE] keys together.

For further details, please consult the next paragraphs..

Note: If the acoustic alarm is very frequent during transmission, the possible causes should be investigated.

In order not to lose the warranty, in the event of a repeated serious alarm, the possible causes must be investigated immediately.

Note: Before the temperature limits are reached, the output power will change from MAX to MID automatically and then possibly from MID to LOW, so that transmission with the amplifier may continue with reduced power. If the temperature, in LOW, is allowed to rise further, a "SERIOUS" alarm will eventually be activated and the linear amplifier switches back to STANDBY.

Note: During a SERIOUS alarm, there will be an acoustic alarm for 10 sec. Pressing the [DISPLAY] key, will enable the system to switch back to 'STANDBY' state immediately and the sound will cease.

Note: ATTENTION : when a "FATAL" alarm occurs, immediately contact your reseller.

10. PROGRAMMING

The three keys: [SET], [◀▲] and [▼▶], allow programming the amplifier. They can be used in the following way:

[SET] Use this key to open a menu page, to validate choices and to exit from a menu page.

[◀▲], [▼▶] Use these keys to select options.

A green led illuminates during the programming process. Programming the system is very easy. You will find your programming choices confirmed by the items shown at the lower part of the display.

Note: Programming operations are only possible in 'STANDBY' mode.

Note: Programming changes take effect only after exiting from a menu page (the green led turns off).

Pressing the [DISPLAY] key for more than 1 sec. it will immediately exit to STANDBY with no programming effect.

10.1 Ways to operate

Pressing the [SET] key opens the menu page, on the display there are the following options:

- a) CONFIG: Select "BANK A" or "BANK B", "REMOTE, / SO2R MATRIX", "COMBINER"



- b) ANTENNA: An antenna may be assigned to each band selecting the (ANT 1, ANT 2, ANT 3, ANT 4) connector. If you don't have an antenna for a particular band, set it to "NO".

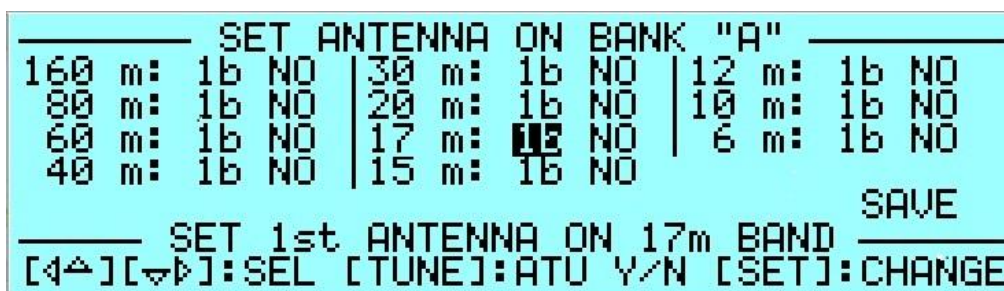

This setup allows you to preset up to 2 antennas for the same band.

The selected antennas can be switched using the [ANT] key while working either in the "OPERATE" or in the "STANDBY" mode and there is no transmission in progress.

- c) CAT: Allows you to program the amplifier to accept control commands from specific transceiver types.
You should refer to your transceiver user manual to ensure that it is correctly programmed to handle such a link.

```

_____ SET CAT INTERFACE ON INPUT 1 _____
10000
KENWOOD      TEN-TEC      BAND DATA
YAESU        FLEX-RADIO  NONE
              ELECRAFT  EXIT

_____ SET INTERFACE TYPE _____
[←▲][▽▶]:SELECT      [SET]:CONFIRM
  
```

Choose the brand of transceiver or function.

For the proper link wiring, see "CONNECTIONS" in this manual.

- ICOM Set to "CI-V" protocol. You also need to choose the baud rate, which is usually 9600.
- KENWOOD You have to choose the baud rate (almost always 9600).
- YAESU If you use the CAT connection (read the "CONNECTIONS" chapter of this manual), select the model of the transceiver and then select the baud rate (almost always 4800). If the model isn't in the list, select "Band Data" and read the "CONNECTIONS" chapter of this manual. For new transceiver models not listed, select FT 2000/9000 or try "Kenwood".
- TEN-TEC Make the CAT connection (read the "CONNECTIONS" chapter of this manual) and follow the menu instructions.
- FLEX-RADIO Make the CAT connection (read the "CONNECTIONS" chapter of this manual) and follow the menu instructions.
- ELECRAFT Make the CAT connection (read the "CONNECTIONS" chapter of this manual) and follow the same indications as for KENWOOD.
- BAND DATA Alternative connection to the CAT (see the chapter "CAT connections" of this manual).
- NONE (Not recommended), to be set only when the CAT connection with the transceiver is not possible, only the internal frequency meter is used (see page 11).

Note: When using the CAT link, check that the baud rate of your transceiver is set to the same value as the amplifier.

Attention: if a new CAT is set up, the linear must be switched OFF and then ON.

- d) **MANUAL TUNE:** Allows you to tune the amplifier manually.
However achieving a better setting than that obtained by automatic tuning is very unlikely.

```

MANUAL TUNE ON BANK "A"
CAT: 21.275 MHz          SUB-BAND: 110
[◀L] ..... [L▶]      1.00 μH
[◀C] ..... [C▶]      87.5 PF(Hi)
[TUNE]: TUNING          SWR ANT: --.--

IN | BAND | ANT | CAT | OUT | SWR | TEMP
 1 | 15 m | 1   | ICOM | MAX | --.-- | 24°C

```

Set your exciter to transmit a continuous RTTY or FM signal.
Then press the [◀L], [L▶], [◀C], [C▶] keys until you obtain the minimum SWR.
To memorize, press the [TUNE] key in addition to the PTT.
The operating frequency and the sub-band are also shown on the Display.

- e) **DISPLAY:** Adjusts the backlight and the contrast of the display.
- f) **BEEP:**
On : All acoustic warning alarms operate and a beep confirms a keystroke.
Off : *In this condition, when you press a key there is no beep feedback, but for all warning conditions and alarms, the acoustic warnings are still functional.*
- g) **START:**
Stby: Sets STANDBY mode at startup.
Oprt: Sets OPERATE mode at startup.
- h) **TEMP / FANS:**
Celsius: Displays the temperature expressed in "Celsius".
Fahrenheit: Displays the temperature expressed in "Fahrenheit".
Normal: The speed of the fans is set for minimum noise.
Contest: The speed of the fans is increased.
- i) **ALARMS LOG:** Shows only the ten most recent "SERIOUS" alarms.
- j) **TUN ANT:** Allows you to associate a tunable antenna to one of four ANT connectors.
A "t" highlights the selected antenna and the ATU is in BYPASS.
- k) **RX ANT:** Allows you to set a single receiving antenna.
A "r" highlights the selected antenna.

11. INITIAL OPERATION OF THE AMPLIFIER

Before turning ON the amplifier, **read this manual carefully.**

The following preliminary operations are necessary:

- 1) Ensure that the mains voltage is within the proper range of the amplifier's power supply requirements.
- 2) Connect the amplifier to a good ground circuit.
- 3) Connect the antennas.
- 4) Connect the amplifier to the transceiver (read the "CONNECTIONS WITH THE TRANSCEIVER" chapter of this manual).

Operate [I] on the main switch on the back panel. Press the [ON] key on the front panel. Select the INPUT where the transceiver is connected, always perform programming with the amplifier in STANDBY.

If you change memory BANK you have to repeat this programming.

Note: You may have to repeat some programming if you change antenna, transceiver, etc.

Note: **ATTENTION:** The 'RELAY' and 'CAT' signals in some types of transceivers are only turned ON from a transceiver menu. Refer to the user manual.

Note: **ATTENTION:** When the amplifier is in the 'STANDBY' and 'OPERATE' modes, always disable the transceiver's autotuner.

11.1 Initial Programming

You must carry out the next steps in the sequence below:

- 1) To Set CONFIG:

Press [SET] and open the "CONFIG" menu page.



Select: [BNK A] or [BNK B].

If you are using the AMB-01 system or the CO1-2 Combiner, select also one of the three other choices.

In this case "R", "S" or "C" will appear before the antenna number.

If you are not using the AMB-01 or the Combiner, go directly to SAVE.

2) To Set ANTENNAS:

Press [SET] and open the “ANTENNA“ menu page.

Assign an appropriate antenna output number for the desired band.

If you don't have an antenna for that band, select “NO“.

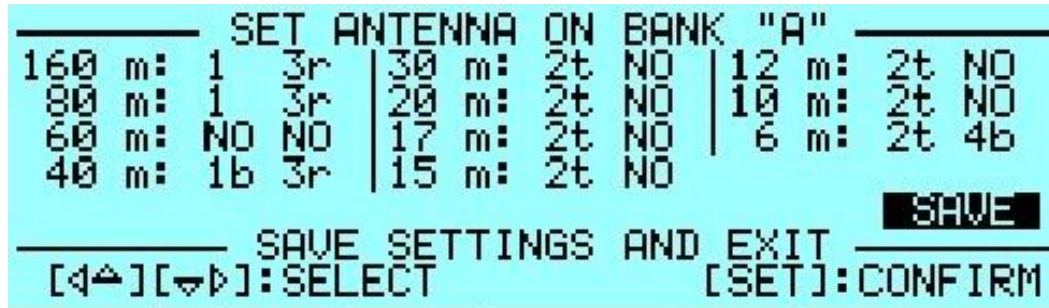

To bypass the Tuner on a certain band and/or a certain antenna, just press the [TUNE] key, you will see a "b" next to the antenna number.

To remove the bypass, just press [TUNE] again.

To select a tunable antenna, refer to the “TUN ANT” item on the menu.

Next to the number of the tunable antenna in use will appear a “t”.

To select a receiving antenna, refer to the “RX ANT” item on the menu.

An “r” will appear next to the number of the receiving antenna in use.

When all the antennas are programmed, press [SAVE] to exit and the screen will go back to STANDBY.

3) To Set CAT:

Press [SET] and open the “CAT“ menu page

Select the transceiver brand and proceed with programming according to the type of connection between the amplifier and the transceiver (read the “CONNECTIONS” chapter of this manual).

At the end of programming, exit and go back into STANDBY.

To verify the correctness of your programming, press the [CAT] key, and all the data stored will appear on the display.

To verify proper “CAT” operation, press [SET], step to “MANUAL TUNE” and push SET. When moving your transceiver's VFO you should see the same frequency on the display.

If “CAT” is set to “NONE”, only the internal frequency meter will work, so to check the frequency transmit in RTTY or FM mode.

ATTENTION: to avoid possible inconveniences, limit the use of the “NONE” to only those instances where the classic CAT connection is not feasible (see page 11).

If “BAND DATA” is used, check that the amplifier follows band changes of the transceiver, then transmit in RTTY or FM in order to verify the frequency.

Exit and return to STANDBY

If it does not do so, verify that your programming (or your connection) has been correctly made.

4) Use of the Automatic Tuner (Internal ATU)

To complete the programming it is necessary to match the antennas to the amplifier by operating the “TUNE” function (read the “TUNER” chapter of this manual).

Select each band (with the proper antenna) and then program the tuner for all the sub-bands of every band.

Refer to the table in section 19 of this manual.

You are strongly advised to proceed with the utmost accuracy, not just match the current frequency, but all the sub-bands of every band

Matching all the antennas on all bands that are available allows you to enjoy all the features of the automatic linear.

To program the sub-bands, proceed as follows:

- For every band find the central frequency in the table of each sub-band (refer to section 19 of this manual).
- Then set the transceiver to that frequency.
Next, set your transceiver to transmit a continuous tone (RTTY or FM).
- Now press the [TUNE] key and then activate the PTT of your transceiver. The procedure for automatic tuning will start, you will hear the ATU relays operate and when they stop, the SWR will be at a minimum.
Sometimes it is possible to improve the tuning by repeating this last step. The use of the “MANUAL TUNE” sometimes helps.
- Repeat the previous steps for all sub-bands.
- Repeat the previous steps for the other antenna (if present) of the same band after having selected it using the [ANT] key.

*Note: If the ALC link is not used, it is **very important** to set the transceiver power to about 30/40 Watts during the above operation.*

The initial programming concludes after steps 1), 2), 3), 4).

11.2 Operating

You need only take a few precautions when using the amplifier, thanks its high level of automation.

The use of both the ALC and CAT connections is highly recommended.

If ALC is not used, SPE reminds you that it is better to lose a fraction of dB in transmitted power, by slightly reducing the driving power, than to over drive the amplifier and have a poor quality transmission and frequent alarms.

During transmission always glance periodically at the parameters on the display. SPE has selected, designed and adjusted them with care for your use in monitoring your amplifier.

SPE recommends, when using the ALC link, that the transceiver be set to its maximum output power as the ALC will automatically reduce the driving power to the optimum driving level.

To reduce the linear output, if required, just switch the amplifier to "MID" or "LOW" with the [POWER] key.

Of course you may also continuously regulate the amplifier's output power by changing the level of drive power from your transceiver , even with the ALC connected.

If an output power less than 1 KW or 500 Watts is desired, for best efficiency begin reducing drive from the "MID" or "LOW" power state. **It is not recommended to reduce the drive while in MAX or MID to an output that is close to the next lower power.**

For example, delivering only 500 Watts in MAX thinking not to stress the amplifier you will get exactly the opposite result.

In fact in this case the MOSFET dissipates about 680 W, while in LOW delivering the same output power would dissipate just 250.

430 W lost used only to raise the temperature of the MOSFET and possibly damage it.

If the ALC link is not used, at each switching from MAX to MID or LOW, remember to first manually reduce the driving power to avoid dangerous overdriving.

The heatsink temperature is continuously monitored:

in MAX it switches to MID at 75°C (167.00°F), it switches to LOW at 76°C (168.80°F), it is switched to STANDBY at 77°C (170.60°F). If this last unlikely state is reached, it is a good idea to investigate the possible causes starting with cleaning the air filter where present.

Setting Driving Levels

- a) SSB: Regulate the "MIC GAIN" of the transceiver until, speaking normally into the microphone, the signal peaks on the display and does not quite reach the maximum rated output power. Monitoring the transmission is a good way of checking your settings. If there is however some distortion, decrease the mike gain or decrease the power of the transceiver until a small reduction of the output power of the amplifier is seen.

In any case the indication of the ALC on the transceiver display must be respected.

b) CW: In key down, you get the maximum output power automatically.

c) Digital modes: The amplifier is full I.C.A.S. able to manage at full power SSB, CW FT8 and JT65 modes.

A suitable SW automatically switches from MAX to MID for a continuous transmission longer than 1 min.

In the modes in which audio signals coming from PC are transmitted, to bypass the possible delay action of the internal ALC of the transceiver, we suggest:

1. Maintain the ALC link with the linear.
2. Set the transceiver Pout to maximum.
3. Adjust the PC audio output exclusively through PC commands until the maximum (or less) available RF power is obtained. The indication of the ALC on the transceiver display must be respected.

Probably the most common causes of problems are overdriving the rig, and ground loops. Avoiding ground loops is generally not too difficult if you use isolated (galvanically or optically) inputs and outputs.

It is assumed that a fixed gain audio input is used in the transceiver.

In case of input via microphone connector, leave the "MIC GAIN" set in the position used in SSB and adjust the audio level via PC.

The presence of the ALC connection allows you to adjust the driving signal by switching to MID and LOW without having to readjust the signal via PC.

With Flex or Elecraft transceivers, where the ALC is not usable, always follow steps 2, 3. but you have to manually adjust the audio via PC if you move from MAX to MID or LOW or refer to page 45.

d) AM: This transmission mode radiates a continuous carrier which is 25% of its PEP value (e.g. 400W PEP AM = 100W carrier power).

To get an output signal without distortion, proceed as follows:

Transmit the AM carrier with your transceiver's "MIC GAIN" set to zero, then increase the transceiver's drive until the 25% of the maximum output power you want have is reached.

Speak into the microphone normally, then set the "MIC GAIN" of the transceiver until the peak output power shown on the amplifier display is no more than 800W (MID) or 400W (LOW).

SPE suggests to monitor your transmission closely to check that the "MIC. GAIN" setting is correct.

e) FM: By monitoring your transmission you can easily get the correct emission by adjusting the. "MIC GAIN".

A suitable SW automatically switches from MAX to MID for a FM transmission longer than 1 min.

12. CONNECTIONS

Since the connectors are identical in all Expert models, standard cables can be used for each model.

12.1 CAT 1 / CAT 2 Connectors

The pin outs are shown in the schematic below.

The connections are the same for our 1K-FA, 1.3K-FA, 1.5K-FA and 2K-FA amplifiers.

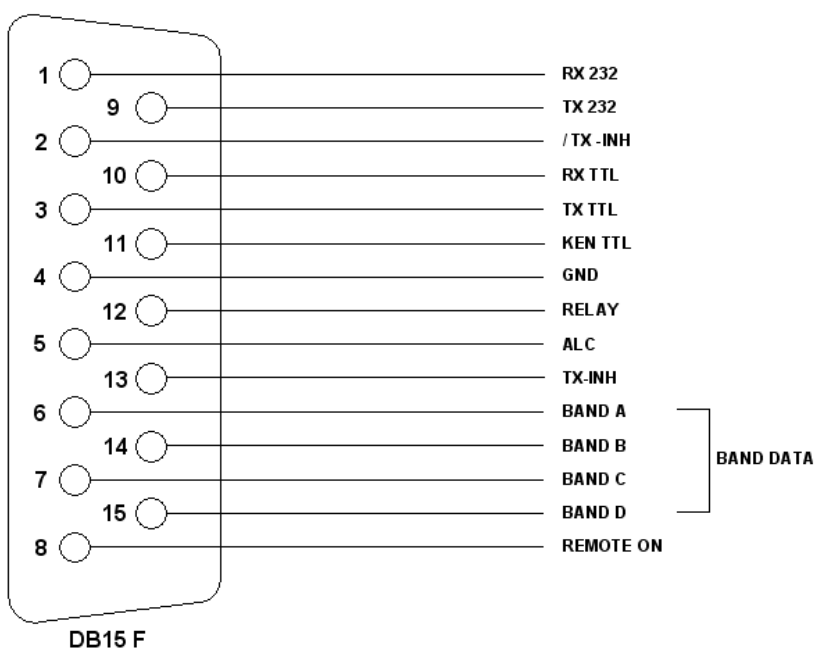

pin n.	pin name	Description
1	RX 232	Used on KENWOOD and YAESU transceivers for linking with a RS-232 connection.
9	TX 232	
2	/ TX - INH	Open collector normally OFF, it stops transmission when grounded. (ON).
10	RX TTL	Used on Icom, KENWOOD and YAESU transceivers for the CAT 5V TTL connection.
3	TX TTL	
11	KEN TTL	Connect to GND if CAT 5V TTL KENWOOD connection.
4	GND	Signal ground.
12	RELAY	Connected in parallel with the RCA phono RELAY connector.
5	ALC	Connected in parallel with the RCA phono ALC connector.
13	TX - INH	Normally to gnd. (550 ohm), it stops transmission when + 12V
6	DATA A	Bit A of Band Data.
14	DATA B	Bit B of Band Data.
7	DATA C	Bit C of Band Data.
15	DATA D	Bit D of Band Data.
8	REMOTE ON	Applying a voltage from 9 to 15 VDC, turns the amplifier ON.

BAND DATA CODES

Band	BCD code	Band	BCD code	Band	BCD code
60 m.	0x0	30 m.	0x4	12 m.	0x8
160 m.	0x1	20 m.	0x5	10 m.	0x9
80 m.	0x2	17 m.	0x6	6 m.	0xA
40 m.	0x3	15 m.	0x7		

The construction of the connection cable between this connector and the transceiver is described below according to its brand and type of interfacing (see page 11).

The linear side connector is supplied, while the opposite side one is normally supplied with the transceiver (called Radio in the following figures).

For connections, consult the specific operating manuals.

12.2 Icom

CAT CI-V Interface

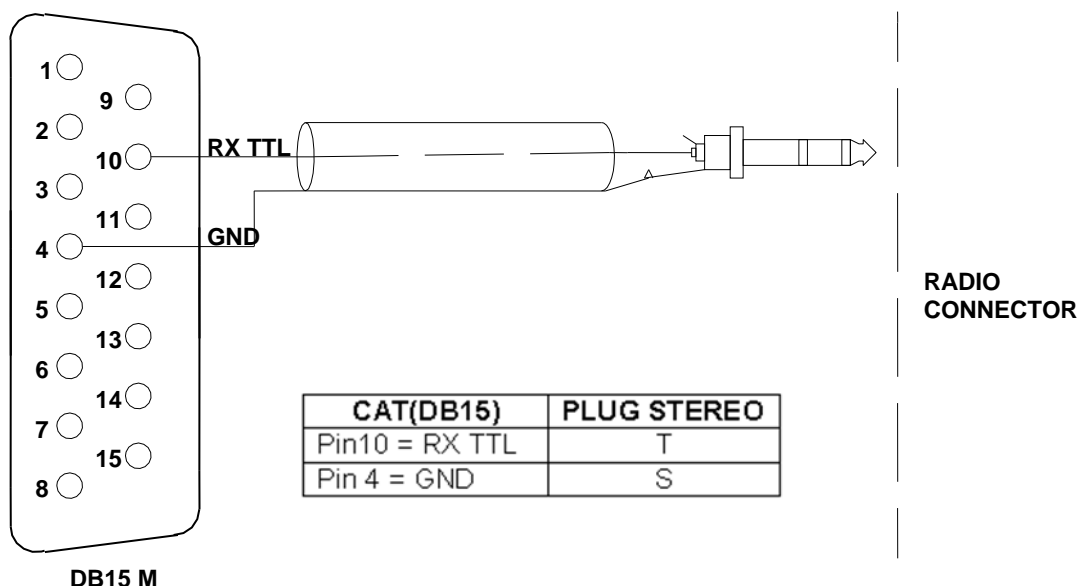

This interface is standard for all the Icom models equipped with CAT. The cable always terminates into a 3.5 mm. mono plug. It is possible to use a stereo plug according to the above diagram. The plug is inserted into the "Remote" connector of the transceiver.

In addition to the standard cable which only contemplates the passive reception function of the data coming from the transceiver, the addition (optional) of the "TX interface" (see fig.) is foreseen to enable the amplifier to interrogate the transceiver cyclically as happens in the Yaesu and Kenwood protocols.

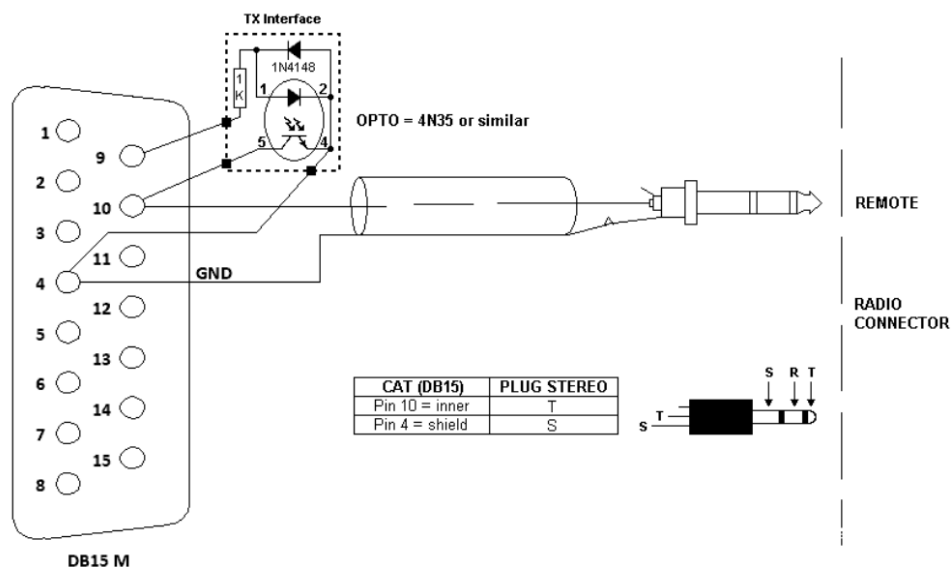

By using the cable without said interface (standard cable), complete operation will be achieved only in the presence of an external software that cyclically interrogates the transceiver (e.g. LOG in a PC).

The addition of the "TX interface", despite its simplicity (only three components to be inserted in the cable cover), gives the linear / transceiver system an exceptional operating stability which is only necessary when no external element (e.g. PC) provides for a cyclical request.

When using a standard cable, the CAT address in the Expert must be set as "DISABLED".

When using a cable with "TX interface", the CAT address in the Expert 1.5K-FA must be the specific address of the transceiver.

In the transceiver menu:

Set "CI-V Output (for ANT) ON" (if present).

Set "CI-V Transceive ON" (in the absence of the previous one).

With one of the previous settings, the transceiver transfers the frequency at each tuning variation even in absence of the cyclic interrogation.

If the transceiver is still interrogated (PC or "TX interface"), "CI-V Transceive OFF" is also a possible setting.

Make sure that the baud rate is the same on both the transceiver and the amplifier.

The following simplified TX interface is possible, valid only if linear and transceiver are simultaneously ON.

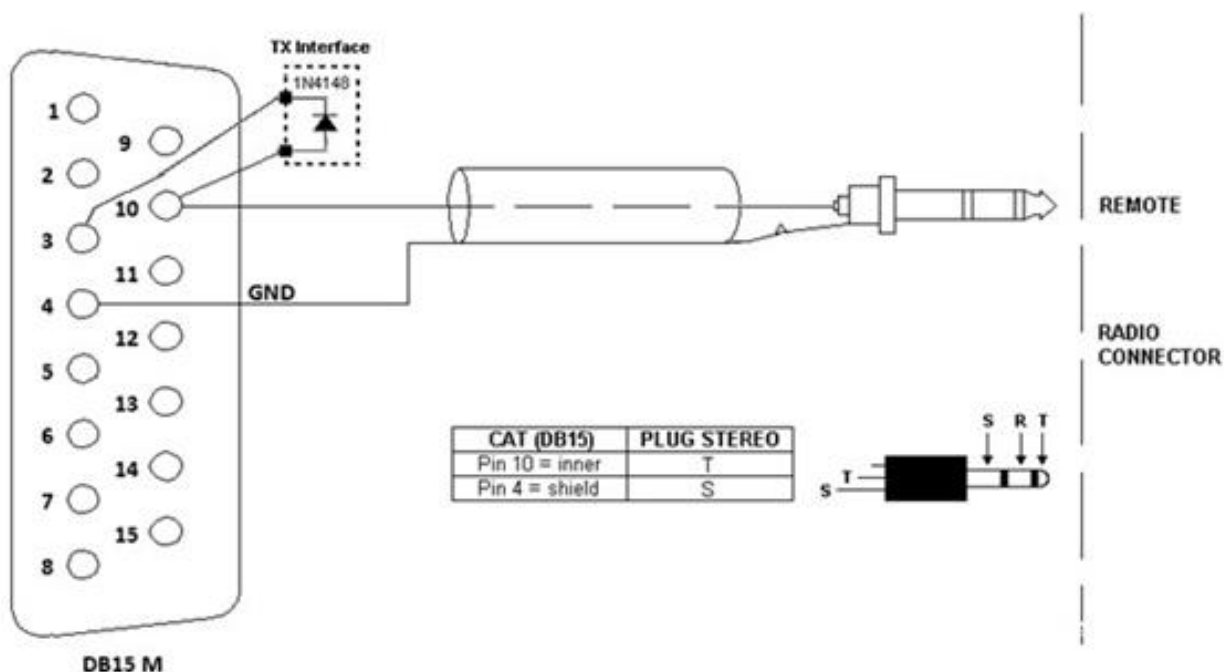

ATTENTION: If there is, in addition to the amplifier query, another CI-V query (e.g. Log, FT8 or other program), a conflict could be generated. If this happens, set the CAT as "DISABLED" in the amplifier.

12.3 Kenwood

CAT RS232 Interface

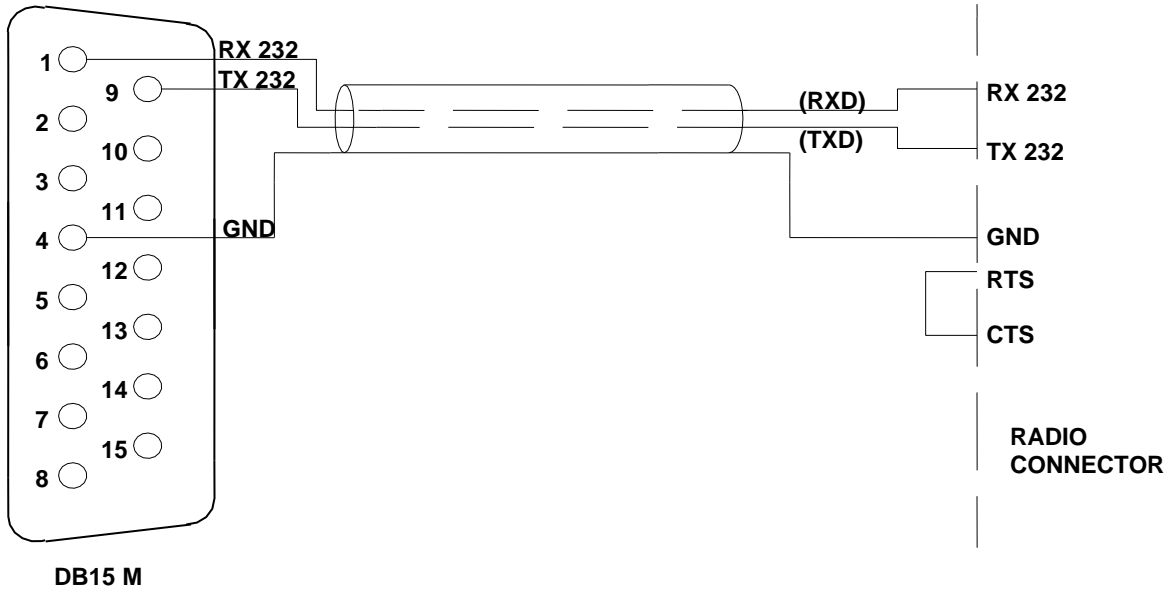

The Radio connector could be DB-9 or DB-25 male connector or female connector (read the specific manual). In the manual, also verify if the RTS–CTS link is required.

CAT 5V TTL Interface

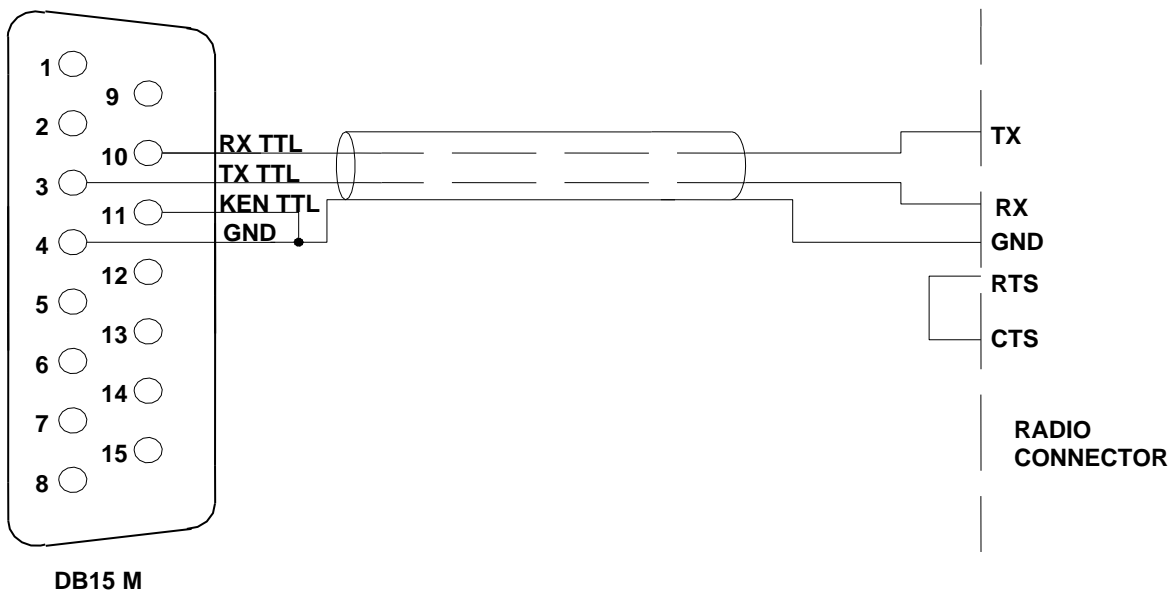

The connector is described in the transceiver’s manual. Verify if the RTS–CTS link is required by the transceiver.

12.4 Yaesu

CAT RS232 Interface

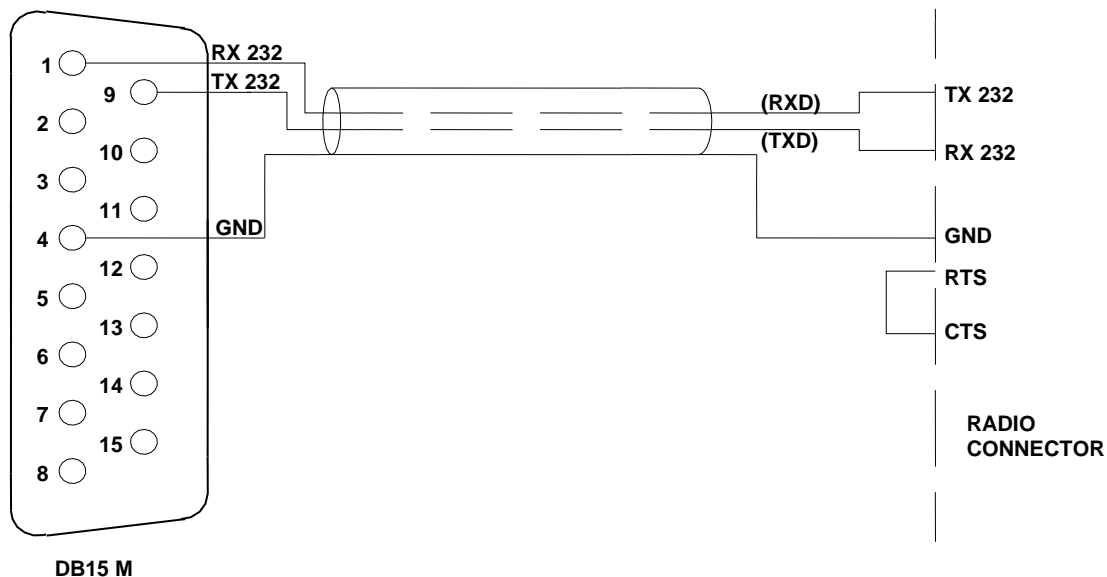

The radio connector may be a DB-9 or DB-25 male connector or female connector (read the specific manual). Verify from the manual if the RTS–CTS link is required.

CAT 5V TTL Interface

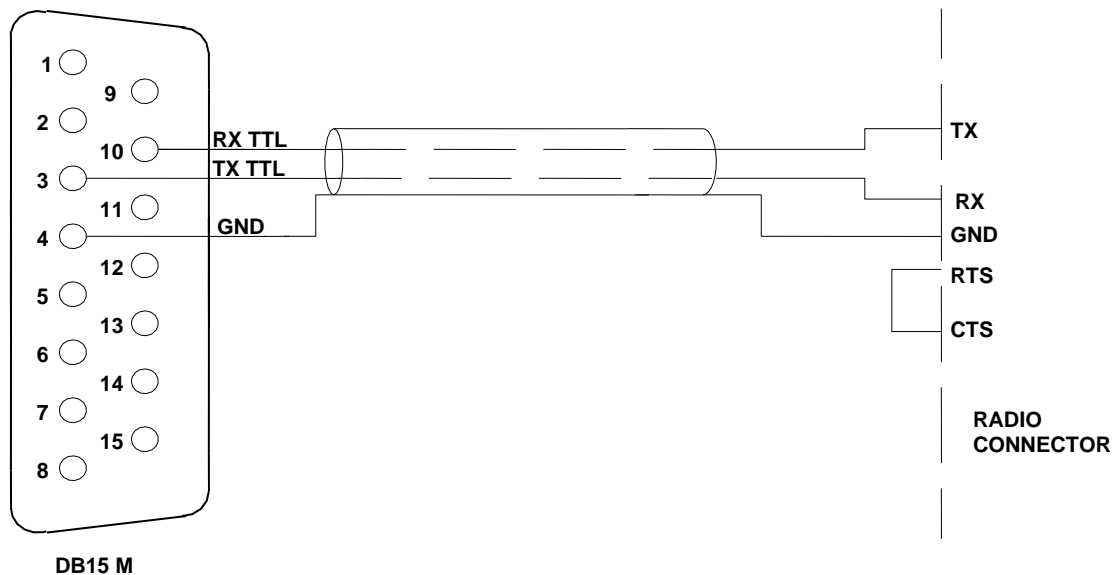

The connector is described in the transceiver’s manual. Verify if the RTS–CTS link is required by the transceiver.

15.5 BAND DATA Interface

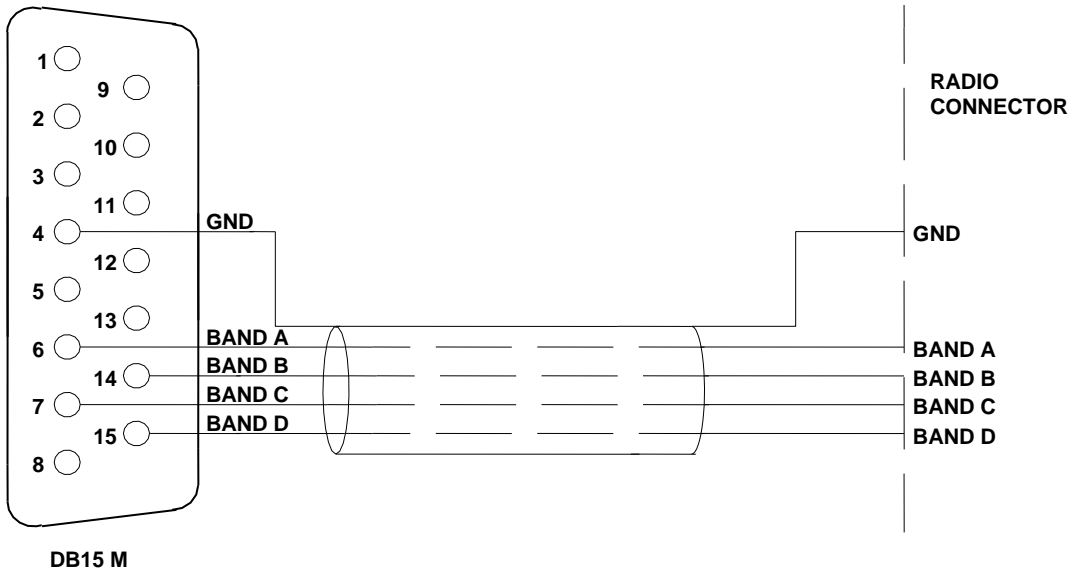

Using Band Data, instead of CAT, use the four digital signals (Band A, Band B, Band C, Band D) from the transceiver. Refer to the transceiver’s manual.

12.6 Ten - Tec, Flex-Radio, Elecraft

CAT RS232 Interface

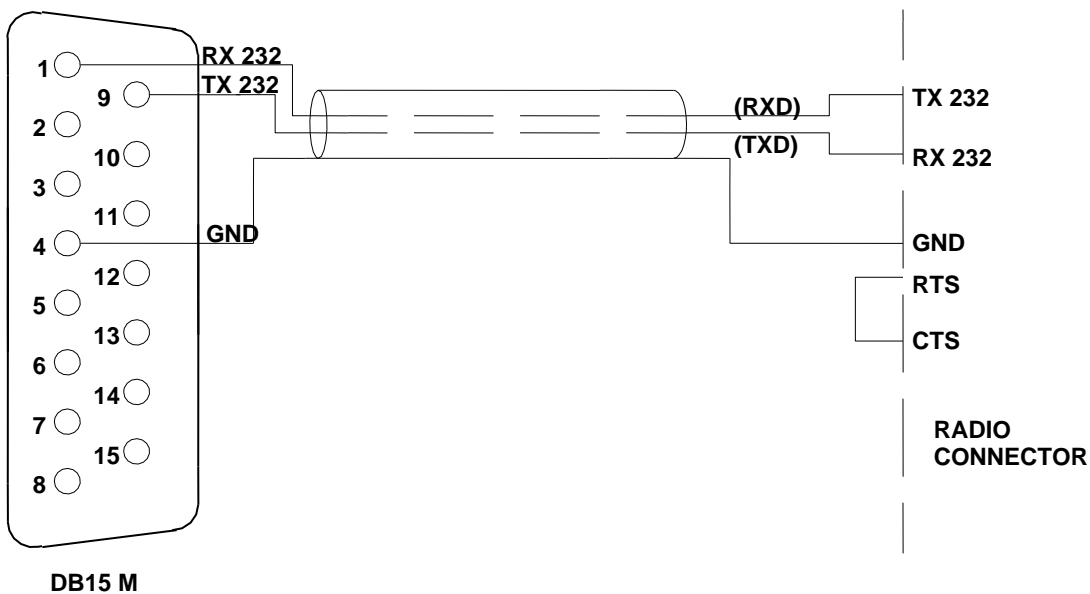

The radio connector may be a DB-9 or DB-25 male connector or female connector (read specific manual). Verify from the manual if the RTS–CTS link is required.

12.7 ALC with Flex-Radio (other SDR, Elecraft)

Since Flex-Radio transceivers, like any SDR equipment, do not have the necessary input to receive the analog ALC signal from the amplifier, it is possible to manually preset the transceiver output power at MAX, MID and LOW levels in order to avoid the danger of over-driving the Expert.:

For every ham band three settings are allowed (storage memories):

- One setting for MAX mode.
- One setting for MID mode.
- One setting for LOW mode.

The following table shows an overall vision of these settings:

Band	160 m	80 m	60 m	40 m	30 m	20 m	17 m	15 m	12 m	10 m	6 m
MAX	Preset Max	Preset Max	Preset Max	Preset Max	Preset Max	Preset Max	Preset Max	Preset Max	Preset Max	Preset Max	Preset Max
MID	Preset Mid	Preset Mid	Preset Mid	Preset Mid	Preset Mid	Preset Mid	Preset Mid	Preset Mid	Preset Mid	Preset Mid	Preset Mid
LOW	Preset Low	Preset Low	Preset Low	Preset Low	Preset Low	Preset Low	Preset Low	Preset Low	Preset Low	Preset Low	Preset Low

To set the memories proceed as follows:

- 1) Connect the CAT of the amplifier with the CAT of the Flex-Radio with the appropriate cable (consult the respective manuals), then select the "FLEX-RADIO" CAT in the Expert menu.
- 2) Switch to "OPERATE".
- 3) Set the transceiver in the band of interest using the CAT.
- 4) Select LOW.
- 5) Without going into transmission, press one of the two arrow keys ([◀▲] [▼▶]) on the EXPERT keyboard, an indication will appear on the Status Bar (above the BAND label) with the following format "[PC=xxx]" where xxx is a numerical value ranging from 000 to 100 which represents the Pout level (expressed as a percentage) of the transceiver relative to the set band at LOW mode.
- 6) Using the arrow keys ([◀▲] [▼▶]) you can decrease / increase the value presented to reach the desired Pout level.
It is advisable to initially start from low values (e.g. 005) and then gradually increase, this is to avoid overdriving the linear.
At the end of the setting you must wait (about 3 seconds) for the "[PC:xxx]" indication to disappear.
- 7) Then go to transmit (RTTY, CW) to check the output power obtained.
If you have not reached the desired Pout, return to point 6 until you reach the rated level or lower (don't overdo it, you risk putting the amplifier into compression).
- 8) Select MID and repeat steps 6 and 7.
- 9) Select MAX and repeat steps 6 and 7.
- 10) Repeat steps 3, 4, 6, 7, 8, and 9 for each available band.

End of programming.

The following picture shows (as an example) the **Power Control** of the **15 m** band in **MAX** power mode:

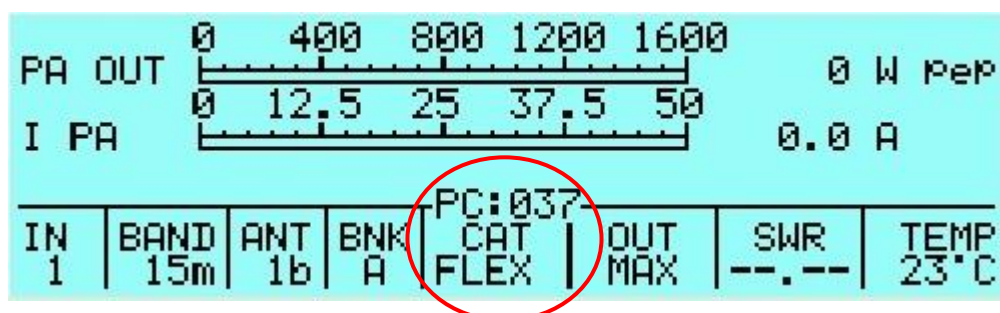

The following empty table is suggested as a template for the Flex Radio user's Power Control adjustments.

Band	160 m	80 m	60 m	40 m	30 m	20 m	17 m	15 m	12 m	10 m	6 m
MAX											
MID											
LOW											

N.B. This procedure has been studied and verified for FLEX transceivers, it should also be valid for all SDRs with Kenwood protocol (check).

Even if the Elecraft transceivers have an ALC input this is not compatible, as they use a Kenwood protocol, to control the Pout of the amplifier it is possible to use the procedure described for the FLEX setting the CAT FLEX-RADIO.

Attention: it is recommended not to exceed the Pout setting, respecting the following levels: LOW (500 W), MID (1000W), MAX (1500W).

The settings must be redone if you change transceiver.

The procedure is valid for both memory banks.

12.8 Transceivers without CAT

Select CAT "NONE":

A special link is not necessary as the internal amplifier frequency counter will measure the input frequency and will control the amplifier (not recommended if a CAT connection is possible, see page 11)..

Note: WARNING, SPE is not responsible for any failure resulting from misuse of hardware interfacing.

13. OTHER CONNECTIONS

On the CAT connector, in addition to the CAT signals, the ALC and RELAY controls are the same as the RCA phone connectors. REMOTE ON, /TX-INH, TX-INH are also available.

If you use this connector to connect the ALC and RELAY lines, the separate RCA phono cables are not recommended. It is possible also to turn the amplifier on / off by turning on / off the transceiver using the REMOTE ON function.

The following are the possible solutions that could be integrated into the same CAT cable.

13.1 ALC, Relay Connections

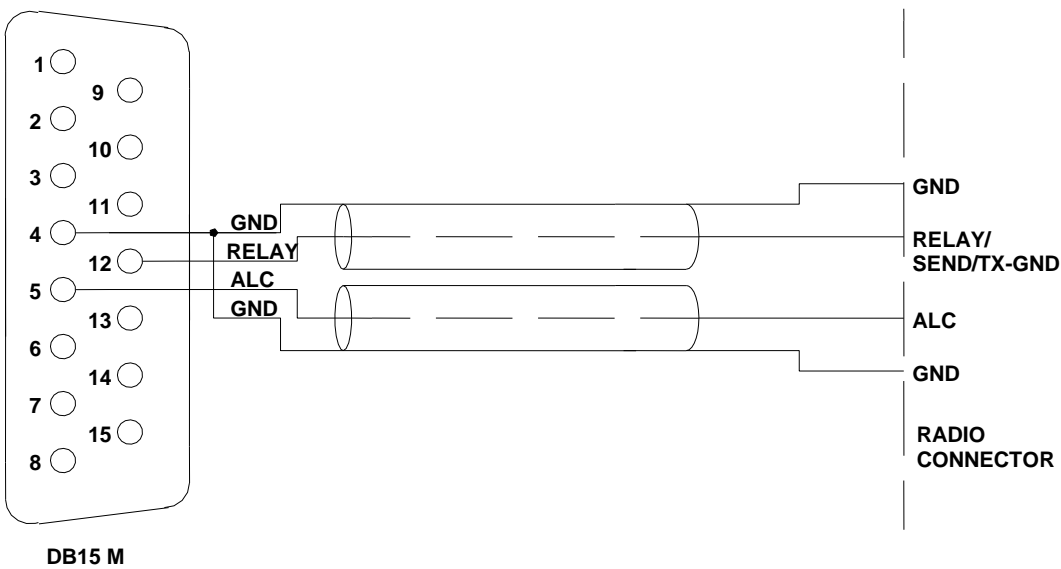

13.2 Remote- ON Link

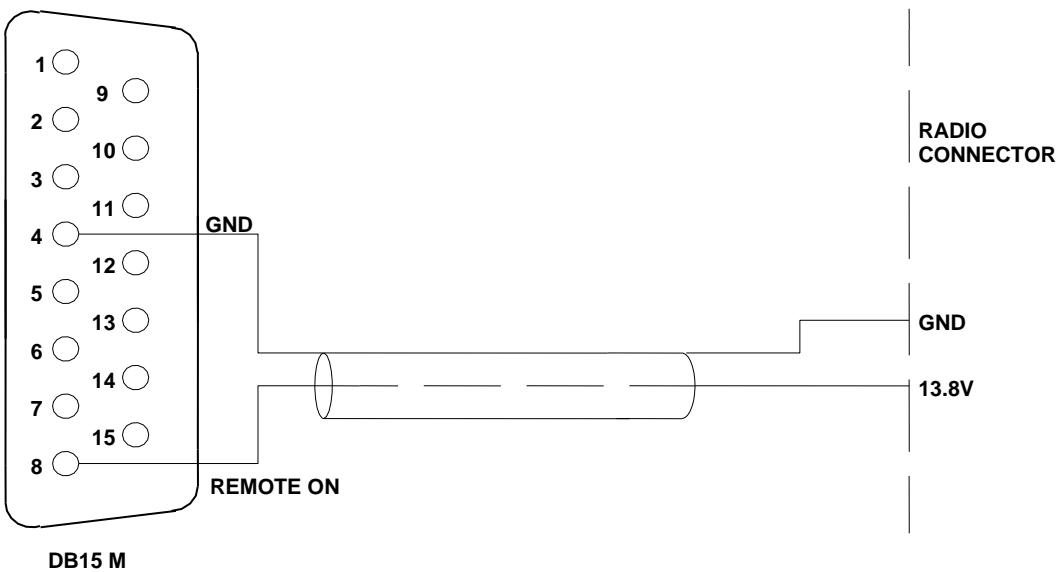

13.3 Connections TX-INH, / TX-INH

All modern transceivers have a delay before the transmission to allow the linear to stabilize their relays avoiding damage to the contacts as a result of "Hot Switching".

The Expert 1.5K-FA has a settling time of less than 6 msec. compatible with all modern transceivers (see the manual of the transceiver).

Some transceivers have an input (called TX-INHIBIT, LINEAR, MUTE, etc..) which disables the transmission.

This input can be used with transceivers that do not have such delay or, more generally, to improve the safety of switching.

The Expert 1.5K-FA has two outputs that can be connected to the TX-INHIBIT of the transceiver:

a) TX-INH, usually gnd. (550 ohm), stops the transmission when at a + 12VDC.

b) / TX-INH, open collector normally OFF, stops the transmission when this line goes to ground (ON).

To choose a) or b) as well as to enable the TX-INHIBIT input , refer to the manual of the transceiver.

TX-INH Link

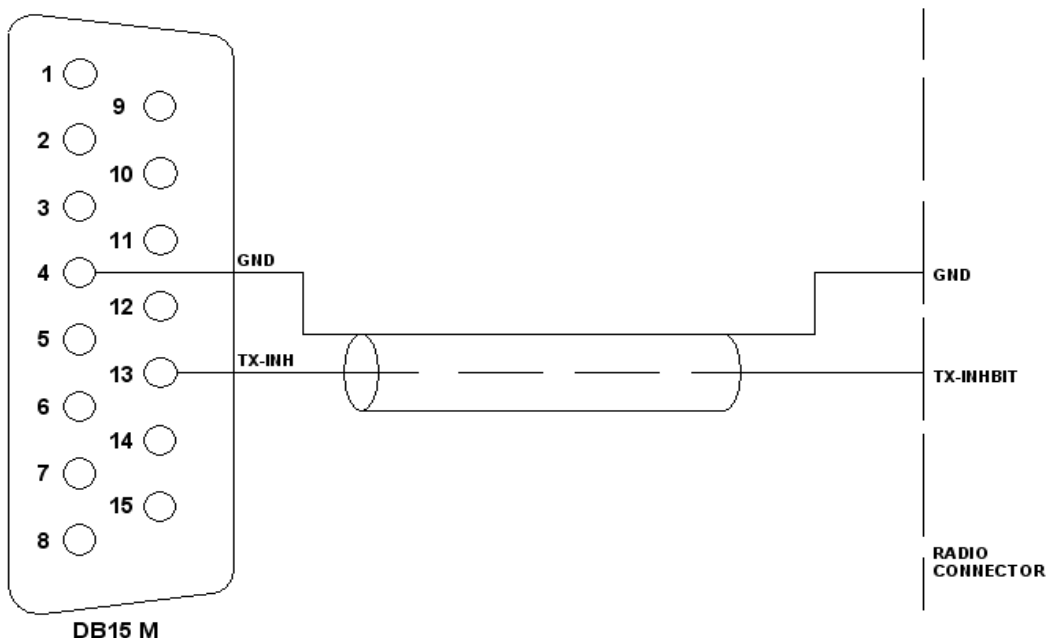

/ TX-INH Link

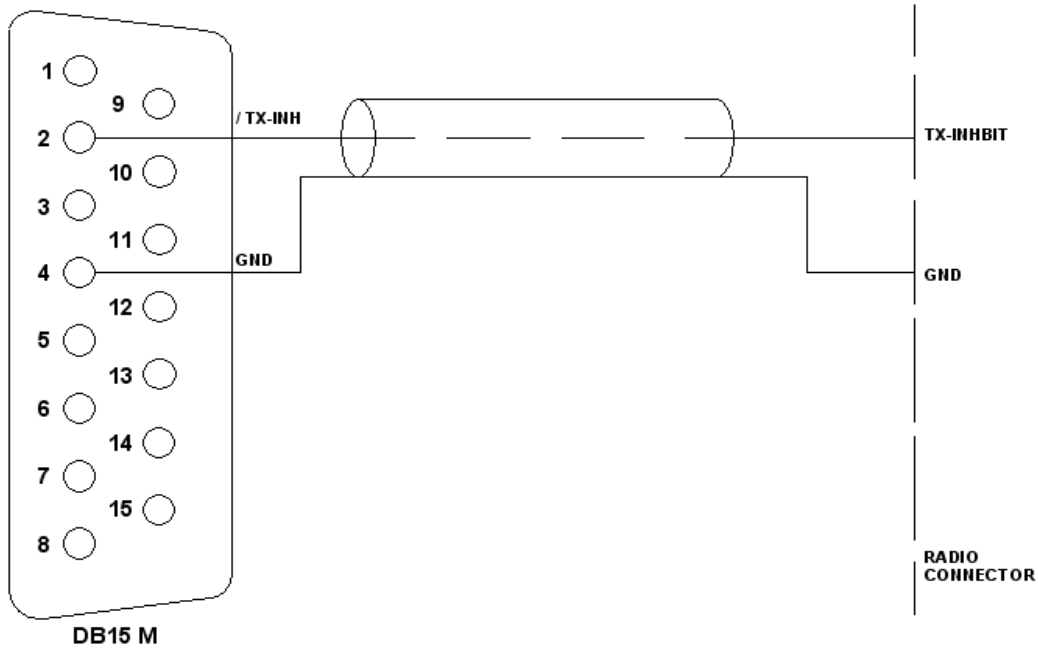

Note: WARNING, SPE is not responsible for any failure resulting from misuse of hardware interfacing.

13.4 AUX Connector

This connector provides data about the bands currently being switched on both INPUTs, indicating which input is connected to the antenna ANT 1/2/3/4 and which is connected to the SO2R socket.

In this way you will know which one of the two transceivers is currently connected to the switched output antenna and when it is in transmission etc.

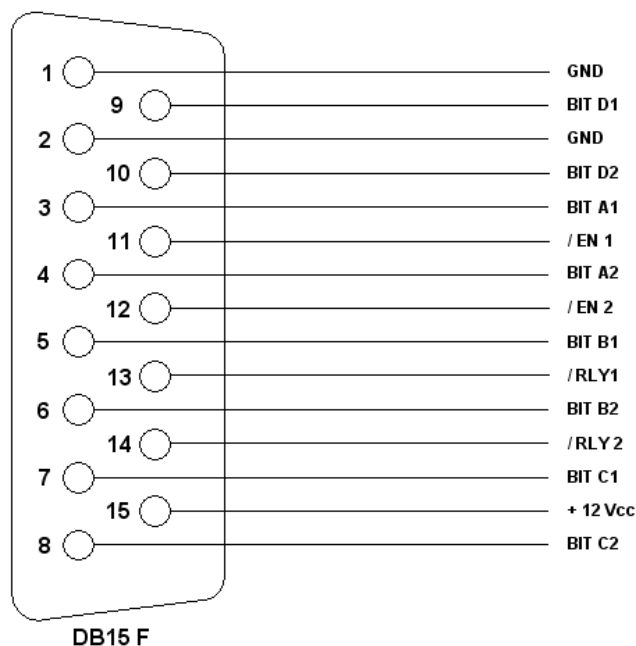

Pin n.	Pin name	Description
3	BIT A1	BIT A INPUT 1 (as for BAND DATA)
5	BIT B1	BIT B INPUT 1 (as for BAND DATA)
7	BIT C1	BIT C INPUT 1 (as for BAND DATA)
9	BIT D1	BIT D INPUT 1 (as for BAND DATA)
11	/ EN 1	INPUT 1 0 = not connected with ANT, 1 = connected with ANT
13	/ RLY 1	INPUT 1 0 = TX state 1 = RX state
1	GND	GND
4	BIT A2	BIT A INPUT 2 (as for BAND DATA)
6	BIT B2	BIT B INPUT 2 (as for BAND DATA)
8	BIT C2	BIT C INPUT 2 (as for BAND DATA)
10	BIT D2	BIT D INPUT 2 (as for BAND DATA)
12	/ EN 2	INPUT 2 0 = not connected with ANT, 1 = connected with ANT
14	/ RLY 2	INPUT 2 0 = TX state 1 = RX state
2	GND	GND
15	+ 12 Vcc	OUT + 12 VDC 0.2 A max.

Each output is an open collector.

Note: **WARNING**, SPE is not responsible for any failure resulting from misuse of hardware interfaces.

13.5 PORT Connector

This connector provides:

- a) BITS A/B/C select in bcd the ANT port currently in use (each output is open collector).
- b) RS 232 port for connection to a controller of a tunable antenna.
- c) RS 232 port for remoting use (as an alternative of USB port).

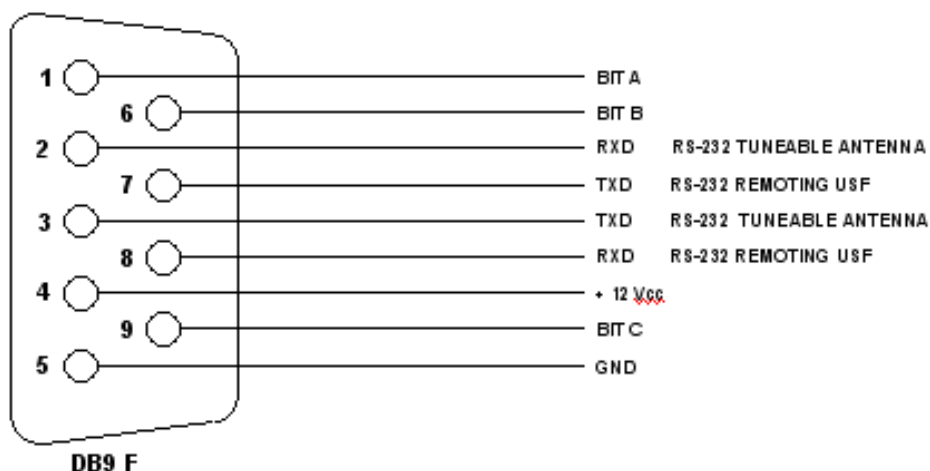

Pin n.	Pin name	Description
1	BIT A	BIT A of the antenna number in use (see ANTENNA menu)
6	BIT B	BIT B of the antenna number in use (see ANTENNA menu)
9	BIT C	BIT C of the antenna number in use (see ANTENNA menu)
5	GND	GND
2	RXD	RS232 port Tunable Antenna
3	TXD	RS232 port Tunable Antenna
7	TX_232 (formerly RTS)	RS232 port Remote use
8	RX_232 (formerly CTS)	RS232 port Remote use
4	+ 12 VDC	+ 12 VDC 0.2 A max.

When connecting to a control box of a tunable antenna a suitable cable should be wired.

SteppIR cable:

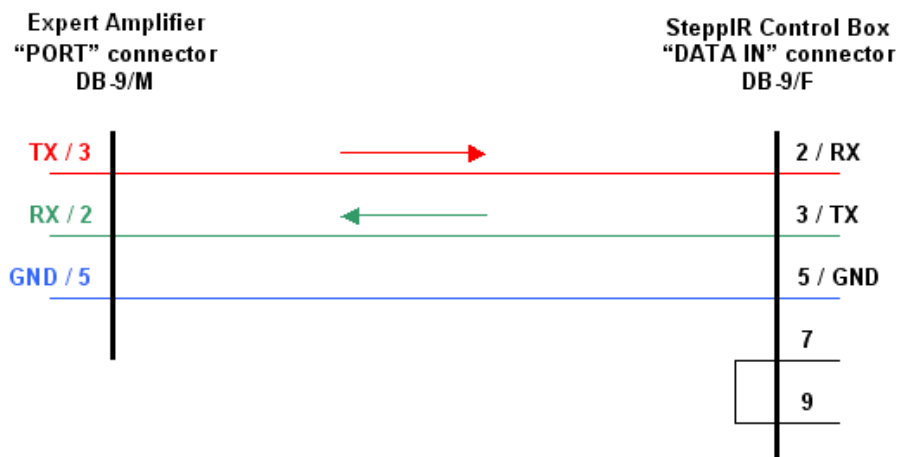

Ultrabeam cable:

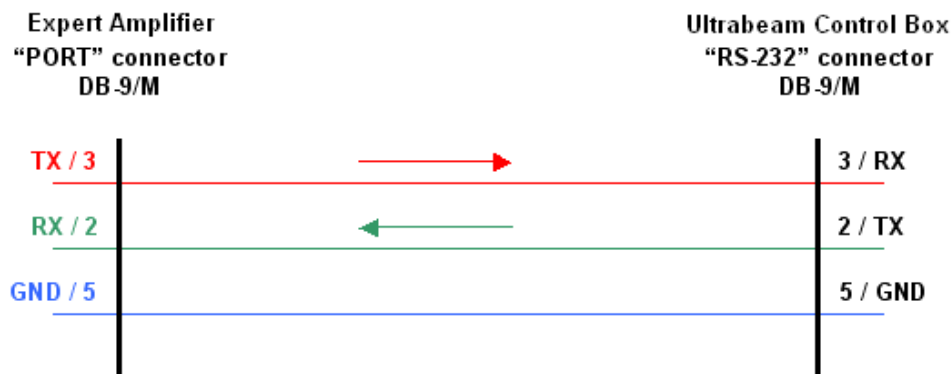

Note: *WARNING, these types of antennas, sometimes need several seconds to adjust to resonance..*
Transmitting with high power while the antenna elements are still moving may cause damage to the antenna and the linear.
To avoid this danger you can utilize some circuitry that inhibits the PTT during the movement of the motors, such as "tuning relays" that are available from the antenna manufacturers.
This solution is highly recommended!!!

Serial connection to a standard PC RS-232 port for remoting use.

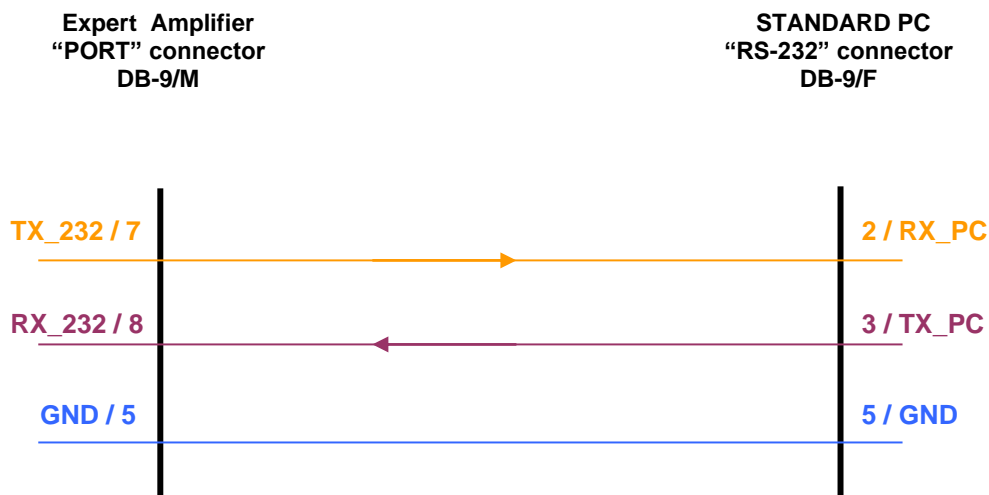

Note: *WARNING, SPE is not responsible for any failure resulting from misuse of hardware interfaces.*

14. TRANSCEIVER CONTROLLED BY PC

If the transceiver is controlled by a PC using the CAT utility, the link with the amplifier can be made as described in the following paragraphs.

Note: BEWARE, SPE assures only the direct connection between the Linear and transceiver. The use of external control software could create malfunctions that must be resolved by the provider of such software and is totally the responsibility of the owner / operator.

14.1 Icom CI-V Interface

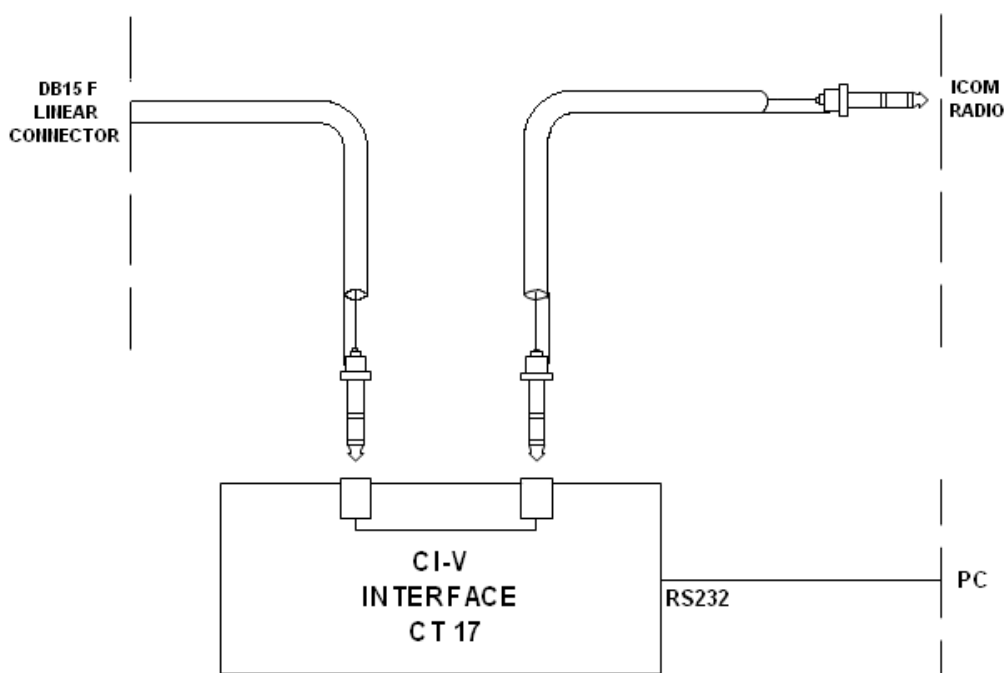

If the PC has an RS232 port, use a CT17 or similar interface and the standard cable for CI-V connection (see page 39).

If the PC has a USB ports only, use an external USB / RS232 converter.

If the transceiver has a USB CAT port, connect it directly to the PC and, with a standard CI-V cable, connect the Expert 1.5K-FA to the "REMOTE" connector of the transceiver.

The following types of connections as described in sections 14.2, 14.3 and 14.4 are common for Kenwood, Yaesu, TEN-TEC, Flex-Radio and ELECRAFT links. The DB-15 connector side of the amplifier remains the same. On the opposite end of the cable, it is necessary to connect only the GND and RX 232 (RX TTL) to the cable PC / Radio.

In this way, the interrogation to the transceiver is no longer requested by the linear but is requested by the PC. The linear analyzes only the data exchanged.

In this case, **DO NOT CONNECT the TX 232 (TX TTL) of the linear because it would create conflict in the software and could damage the hardware as well. (see following diagrams)**

14.2 RS232 Interface

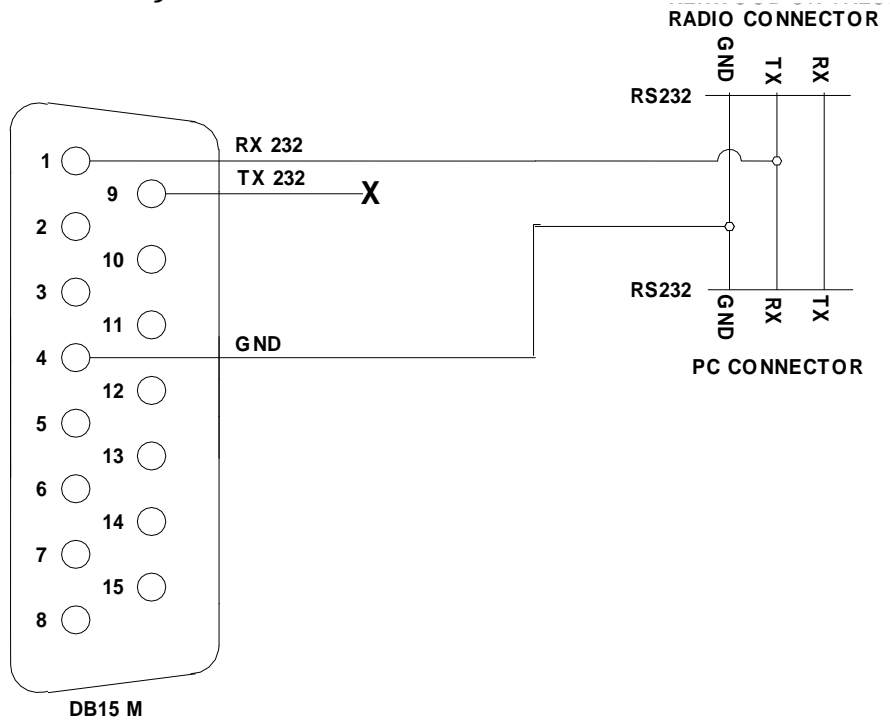

14.3 5V TTL Kenwood Interface

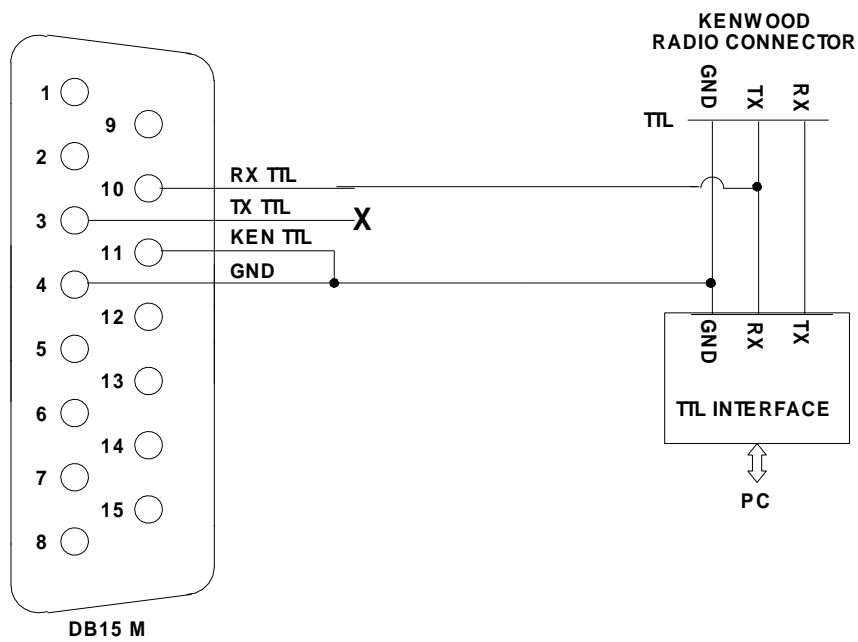

14.4 5V TTL Yaesu Interface

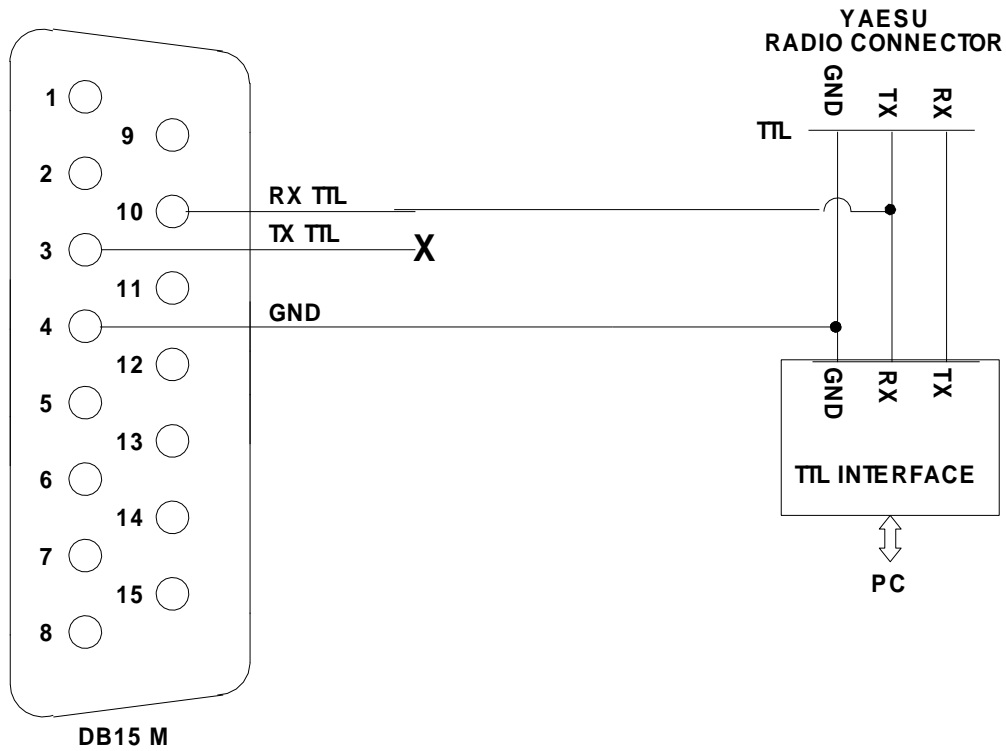

Note: WARNING, SPE is not responsible for any failure resulting from misuse of hardware interfaces.

15. USE OF THE USB / RS232 PORTS

Through the USB / RS232 ports on the rear panel it is possible to interface the amplifier with a PC.

Two features are possible:

- a) To remote the linear.
- b) To download newer and updated firmware releases.

The USB port is recommended in order to directly link the linear with a PC. In this case the Software “Term_1.5K_USB” must be used.

The RS232 port (see “13.5 PORT Connector”) is more suitable for Internet use. In this case the Software “Term_1.5K_232” must be used.

**Both ports should not be used simultaneously !!
Only one port should be used at a time.**

These programs can be downloaded from www.linear-amplifier.com

Note: For Internet use, please refer to the manual of the remote use equipment.

15.1 LAN port

For space reasons it is not possible to put a LAN connector on the rear panel. This can be overcome by using a commercial RS232 / LAN converter externally, a very common and economical product offered by various manufacturers.

Connect the converter to port 232 of the PORT connector (pins 7, 8 and 5). If the converter consumes less than 0.2 A it is possible to use the 12 Vdc present (pins 4 and 5), alternatively use an external source.

For programming, refer to the procedure suggested by the converter manufacturer.

15.2 Remote Control

The software provided allows the operator to display two separate windows.

The first window provides an exact copy of the display and is adjustable in size to fit any need on the control screen.

The second window provides a copy of the keyboard. When not in use, it may be removed to make space on that screen.

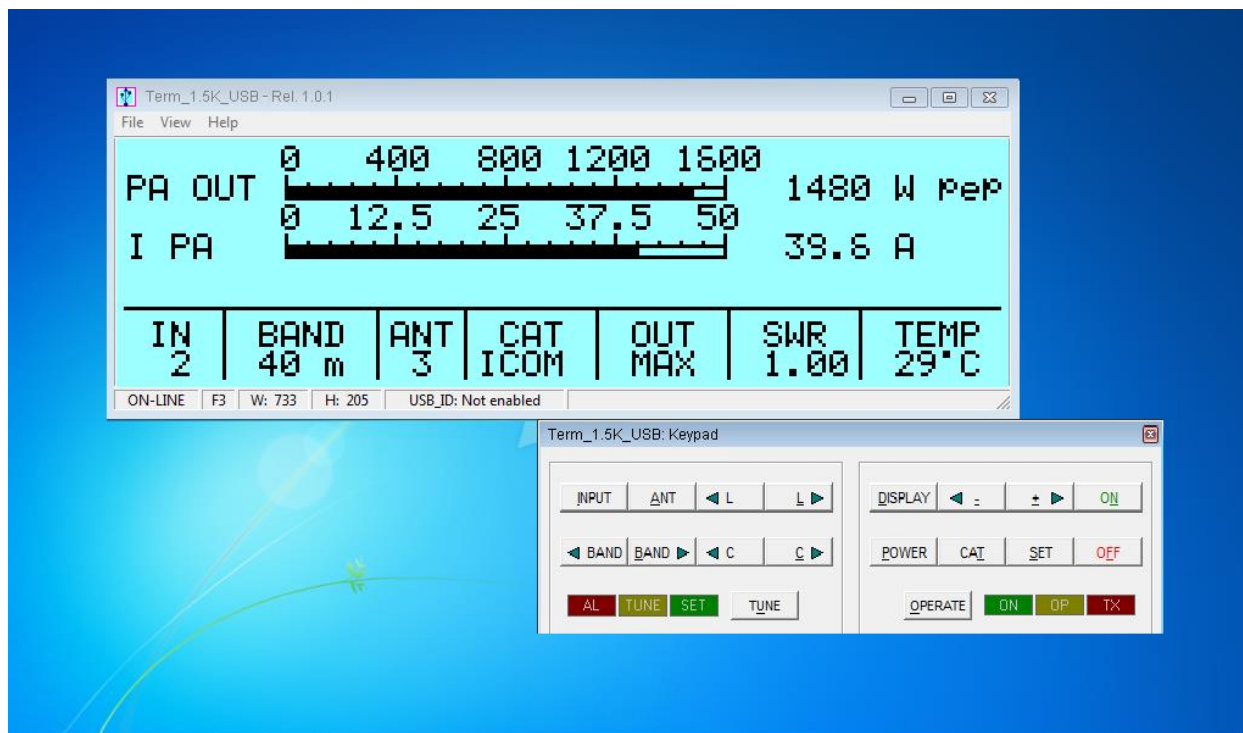

This software allows the same operation as when standing in front of the amplifier.

See "Appendix 1" on this manual.

15.3 Download

The sophisticated design of the Expert 1.5K-FA allows you to download any new versions of Software from the following site:

www.linear-amplifier.com

On this site a software for vision-impaired people is also freely available as well as the "Application Programmer's Guide" where SPE provides its proprietary protocol and necessary explanations.

16. MAINTENANCE

If used in very dusty environments the air filter supplied separately can be installed behind the front panel grid.

Therefore the user only needs to periodically check and clean the air filter on the front panel (if any).

The frequency of air filter inspection depends how dusty the amplifier location is and how much it is used. We recommend monthly cleaning of the filter.

Twice yearly cleaning of the fans with a soft brush is also recommended.

To clean the filter

- a) Remove the front grid cover with the two small screws.
Place small screws in a secure place. **DO NOT LOSE THEM.**
- b) Remove the filter and clean it with care.
- c) Reassemble the filter and the grid after having carefully cleaned the mechanical structure that includes them. Dry filter before re-installing.

Note: Check the filter if an unexpected rise of temperature of the linear is noticed.

Note: To allow the most efficient heat-dissipation of the power amplifier circuits, large copper parts have been used.

17. CHARACTERISTICS / SPECIFICATIONS

- **Double MOSFET with 1.8 KW dissipation each.**
Granting great robustness, efficiency and linearity.
- **The smallest in its class:**
Built-in Power supply and Automatic Antenna Tuner.
Dimension: L 28, H 12, P 38 cm (11.02" W, 4.72" H, 14.96" D) connector included. Approx. weight about 9,5 Kg (20.9 lbs).
- **The most technologically advanced in the world:**
Two powerful CPUs are used.
Over 30,000 lines of software, for performance that cannot be found together in any other amplifier.
- **Fully automatic:**
Easy connection with all models "ICOM, YAESU, KENWOOD, TEN-TEC, FLEX-RADIO, ELECRAFT" for immediate management of the bands, tuner and antennas.
Same performance with all makes and some homemade rigs.
The operator only has to move the "Frequency Tuning Knob" of the transceiver.
- **Wide frequency coverage:**
1.8 MHz to 50 MHz including WARC's.
60 m band, where permitted.
- **Fully solid state:**
Solid 1.5 KW out, HF (+/- 0.5 dB), 50 MHz (+/- 0.8 dB).
Switchable in MAX (full power), MID (1KW) or LOW (500 W), power selected according to the operator's requirement or automatic for amplifier protection.
No warmup time, immediately ready!
- **Automatic antenna tuner built-in:**
Capable of matching up to 5:1 SWR on HF, and 2.5:1 SWR on 6 meters.
Capable of program controlling 4 aerials (SO239 connectors).
Program up to 2 aerials for each band.
Management of SteppIR / Ultrabeam aerials (tunable).
Also measures the SWR of the antenna and cable system.
Bands, aerials, tuning conditions are changed in 10 msec.
Bands, aerials and tuning conditions are managed so that in "STBY", only the exciter is passed through to the output.
Max. attenuation 0.8 dB. ATU bypass capable.
- **SO2R.**
- **Two inputs available:**
SO239 connectors.
- **High power gain (up to 15 dB):**
In "OPERATE" the required drive power is automatically set with the ALC connection.
In "STANDBY" the exciter is automatically reset to full power.

- **Very clean and low distortion output:**

Spurious emissions FCC, CE, RCM (C-Tick) compliant.

3rd order distortion (two tone test) from -32 dB to -38 dB, -35 dB (typ.).

- **Input / Protections:**

50 ohm always perfectly matched, SWR always better than 1.2:1.

Temperature, Voltage, Current, reflected PW, out PW, SWR, Vrf max on tuner, etc. are continuously monitored. The same protection is realized in two different ways:

Via hardware circuits (HW) to assure great speed.

Via software (SW), to assure great accuracy.

Due to the sophisticated software, the transmit relay changeover is carried out with zero current on the contacts. Protection against first spike.

- **Full break-in operation (QSK).**

- **Quiet operation:**

Linear management of the speed of the cooling fans of the heatsink.

The amplifier develops a significant amount of heat that must be removed.

Therefore, every precaution is taken to keep the fan noise at the lowest possible level. Fan noise is significantly lower than with tube type amplifiers.

- **Use:**

Full I.C.A.S. in SSB, CW, FT8, JT65.

In FM the amplifier automatically switches to "MID" if for 1 min. a continuous signal is emitted in "MAX".

- **Switching power supply:**

Continuously operable at inputs between 100 – 255 VAC, 47-63 Hz.

(100-120 VAC may cause slightly reduced output power).

PFC (Power Factor Correction).

- **The linear can be switched ON / OFF by switching the exciter ON / OFF.**

- **Can be operated fully remotable.**

- **With a large LCD display, it is possible to have a great deal of information:**

Watts pep out, Vpa, Ipa, Watts, Temperatures, SWR (after and before the ATU), Input setting, CAT setting, Band and other indications including the alarms log.

- **Easy to operate:**

Powerful and sophisticated software gives you a user-friendly unit.

- **USB / RS232 ports:**

For remote control.

For new software releases download.

- **Easy transportation:**

A sturdy carry-bag is supplied for QSY, FIELD DAY, DXpeditions etc.

- **Certifications:**

CE, FCC. RCM (C-Tick)

N.B. These specifications are subject to change without notice.

18. DIAGNOSTICS.

During normal operation, the sophisticated monitoring system continuously monitors several measurements directly acquired from internal test-points.

When a dangerous situation occurs, an alarm is generated.

The user can either immediately restore the **Main Display Page** by pressing the **[DISPLAY]** key or wait for the visual alarm time-out expiration (about 10 seconds).

The following table shows all the "serious" alarm messages that are recorded in the **Alarm History** stack (the amplifier is switched from **OPERATE** to **STANDBY**).

Message	Description
SWR EXCEEDING LIMITS	Protection for SWR greater than 2.5:1.
INPUT OVERDRIVING	Protection for excessive input power.
EXCESS OVERHEATING	Protection because the internal temperature has exceeded safe limits.
LOW EFFICIENCY	High current with low output power.
RAPID SWR INCREASE..CHECK ANT	Important warning, see § 18.1.

The following table shows all the main warning messages that are **not** recorded in the Alarm History stack:

Message	Description
BAND NOT PERMITTED	Band not allowed or not set.
ANTENNA NOT AVAILABLE	Antenna not set.
TX ANTENNA NOT AVAILABLE	In the selected band only an antenna for reception is set.
INTERNAL OVERHEATING	Appears when the internal temperature reaches 75°C (167°F)). The amplifier automatically switches to the next lowest power level.
HIGH SWR ANTENNA: TUNING NOT ALLOWED	When the antenna SWR is over 5:1, the auto tuner is disabled.
ATU BYPASS: TUNING NOT ALLOWED	Since the tuner is bypassed, it is not possible to match automatically or manually.
NO INPUT POWER: TUNING HALTED	The tuner cannot work at such a low input power.
CAN'T SWITCH-OFF: POWER HELD BY REMOTE	The amplifier does not turn OFF by the keyboard because it is kept ON by a remote device (transceiver or USB port).
CAT ERROR	Wrong hardware or software setting of the CAT.
BAND DATA ERROR	If the BAND DATA communicates an unknown code.

ATTENTION: In the case of repeated alarms, especially of the "serious" type, avoid insisting but try to identify the problem.

If a "serious" alarm occurs 3 times consecutively, to make the operator aware, a "warning" message is written on the display.

Insisting without intervening does not cure the problem but you risk damaging the amplifier thus losing the warranty due to "misuse".

18.1 Rapid SWR Increase... Check ANT

This visual and acoustic alarm is unique in a solid state amplifier because the electrical stability of the antenna is constantly monitored, the operator is alerted of any abnormal increase in SWR during transmission.

Often, without the operator's knowledge, a gradual degeneration of the antenna system can occur during transmission mainly due to excessive heating of the ferrite cores used in the Balun or in the matching transformer if they are insufficient to handle the power sent in the presence of high SWR values,

This extremely dangerous situation is usually attributed to some defective component of the amplifier and not to the antenna as it should be because, at a measurement made at low power, this appears perfect.

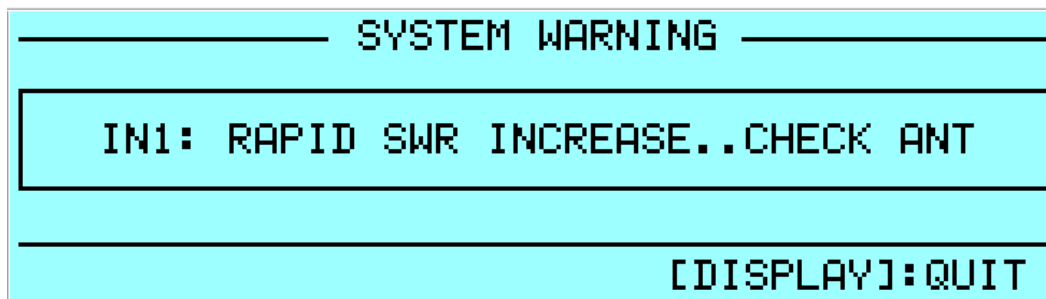

WARNING: Once the Curie temperature is reached, the core loses all its magnetic characteristics, irreparably damaging the amplifier.

For a better understanding of the phenomenon, in OP press the [DISP] key to obtain:

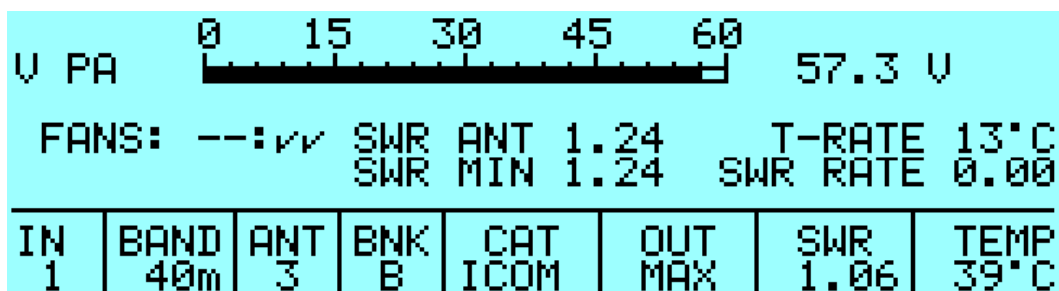

Meaning of the measures:

SWR = Measures the matching of the amplifier.

SWR ANT = SWR of the antenna only during transmission.

SWR MIN = SWR of the antenna detected at the first transmission in OP for each band.

SWR RATE = SWR increase with respect to SWR MIN on which the alarm is calculated.

FANS = The two flags on the left are of the amplifier, those on the right are of the PSU.

TEMP = Temperature of the heatsink.

T-RATE = Variation of the heatsink temperature during transmission.

WARNING: the use of CAT is recommended.

19. TABLE

BAND TABLE, SUB-BAND, CENTRAL FREQUENCY SUB-BAND

160 m	[0] 1785	[1] 1795	[2] 1805	[3] 1815	[4] 1825	[5] 1835
	[6] 1845	[7] 1855	[8] 1865	[9] 1875	[10] 1885	[11] 1895
	[12] 1905	[13] 1915	[14] 1925	[15] 1935	[16] 1945	[17] 1955
	[18] 1965	[19] 1975	[20] 1985	[21] 1995	[22] 2005	[23] 2015
80 m	[24] 3470	[25] 3490	[26] 3510	[27] 3530	[28] 3550	[29] 3570
	[30] 3590	[31] 3610	[32] 3630	[33] 3650	[34] 3670	[35] 3690
	[36] 3710	[37] 3730	[38] 3750	[39] 3770	[40] 3790	[41] 3810
	[42] 3830	[43] 3850	[44] 3870	[45] 3890	[46] 3910	[47] 3930
	[48] 3950	[49] 3970	[50] 3990	[51] 4010	[52] 4030	
60 m	[53] 5013	[54] 5038	[55] 5063	[56] 5088	[57] 5113	[58] 5138
	[59] 5163	[60] 5188	[61] 5213	[62] 5238	[63] 5263	[64] 5288
	[65] 5313	[66] 5338	[67] 5363	[68] 5388	[69] 5413	[70] 5438
	[71] 5463	[72] 5488				
40 m	[73] 6963	[74] 6988	[75] 7013	[76] 7038	[77] 7063	[78] 7088
	[79] 7113	[80] 7138	[81] 7163	[82] 7188	[83] 7213	[84] 7238
	[85] 7263	[86] 7288	[87] 7313	[88] 7338		
30 m	[89] 10075	[90] 10125	[91] 10175			
20 m	[92] 13975	[93] 14025	[94] 14075	[95] 14125	[96] 14175	[97] 14225
	[98] 14275	[99] 14325	[100] 14375			
17 m	[101] 18075	[102] 18125	[103] 18165			
15 m	[104] 20975	[105] 21025	[106] 21075	[107] 21125	[108] 21175	[109] 21225
	[110] 21275	[111] 21325	[112] 21375	[113] 21425	[114] 21475	
12 m	[115] 24891	[116] 24963	[117] 25038			
10 m	[118] 28050	[119] 28150	[120] 28250	[121] 28350	[122] 28450	[123] 28550
	[124] 28650	[125] 28750	[126] 28850	[127] 28950	[128] 29050	[129] 29150
	[130] 29250	[131] 29350	[132] 29450	[133] 29550	[134] 29650	[135] 29750
6 m	[136] 49875	[137] 50125	[138] 50375	[139] 50625	[140] 50875	[141] 51125
	[142] 51375	[143] 51625	[144] 51875	[145] 52125	[146] 52375	[147] 52625
	[148] 52875	[149] 53125	[150] 53375	[151] 53625	[152] 53875	[153] 54125

Note: [sub-band] Central frequency (KHz)

20. APPENDIX 1 - REMOTE CONTROL

Overview:

With reference to that described in Section 15. “**USE OF THE USB / RS 232 PORTS**”, this appendix contains the following sections:

SW installation

Term_1.5K_USB.exe usage

Term_1.5K_232.exe usage

Firmware update

The host PC must have the minimum of a correctly installed Windows XP operating system, or a newer release of Microsoft’s operating system, with a typical minimum of RAM and hard disk space.

20.1 SW (Software) installation.

The installation package is contained in a compressed **.ZIP** archive named “**Term_1.5K_Package_1_0.zip**” which requires to be expanded into a work folder and then processed as described. This package is included in the accessory CD or can be downloaded from our website at www.linear-amplifier.com.

Once the compressed archive **Term_1.5K_Package_1_0.zip** has been stored into a work folder, it must necessarily be expanded; that is all. the files therein contained must be extracted and properly placed into the host system.

In this example the compressed archive **Term_1.5K_Package_1_0.zip** has been placed into a folder named **tmp** which is, in turn, located on the local disk unit **C:** as shown in the picture below:

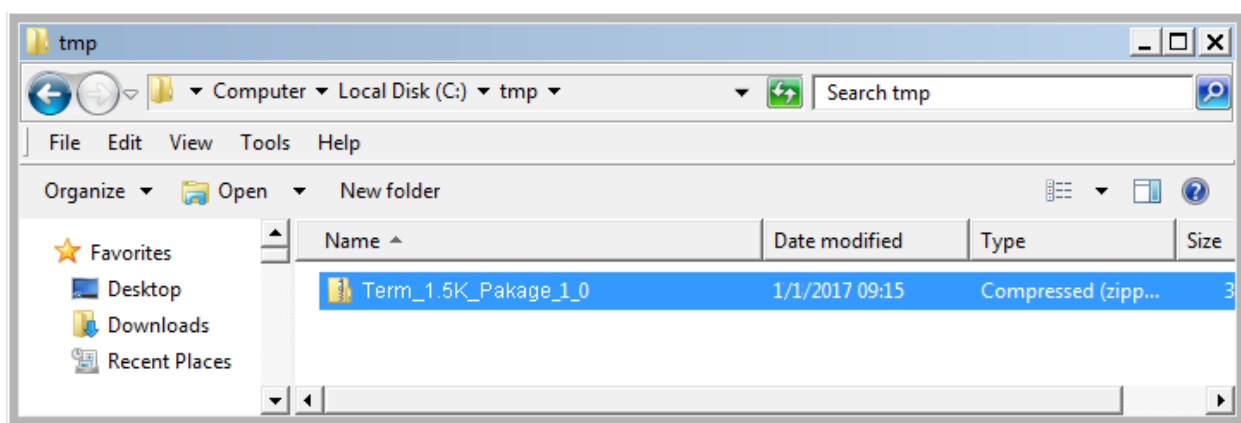

Next step is the archive expansion. This can be obtained by selecting the filename and then right-clicking over it. A local menu will appear, with **Extract All...** this process will automatically sort unzip and sort the files:

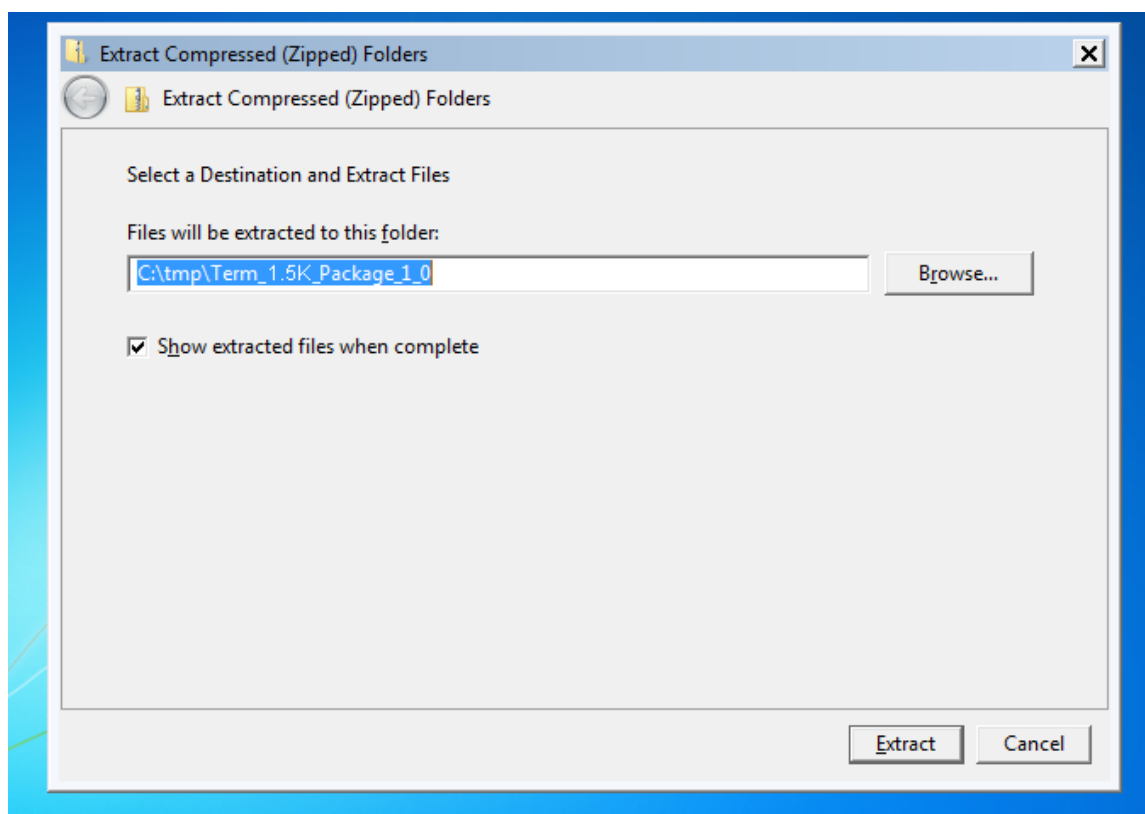
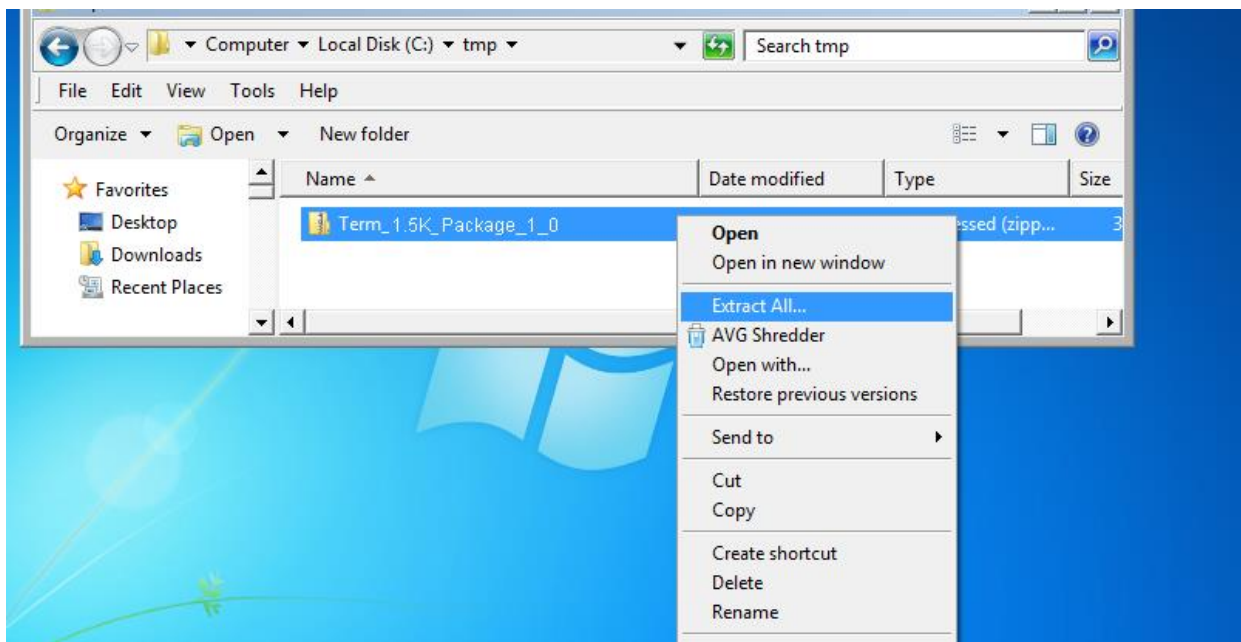

The default destination folder is good for this use, so complete this operation by using the **Extract** key as shown in the picture above.

This step reveals a new uncompressed folder, having the same name of the original compressed one contained in the installation package. Everything is contained in our work folder as shown in the picture above:

Once opened, the **C:\tmp\Term_1.5K_Package_1_0** folder will show the following contents:

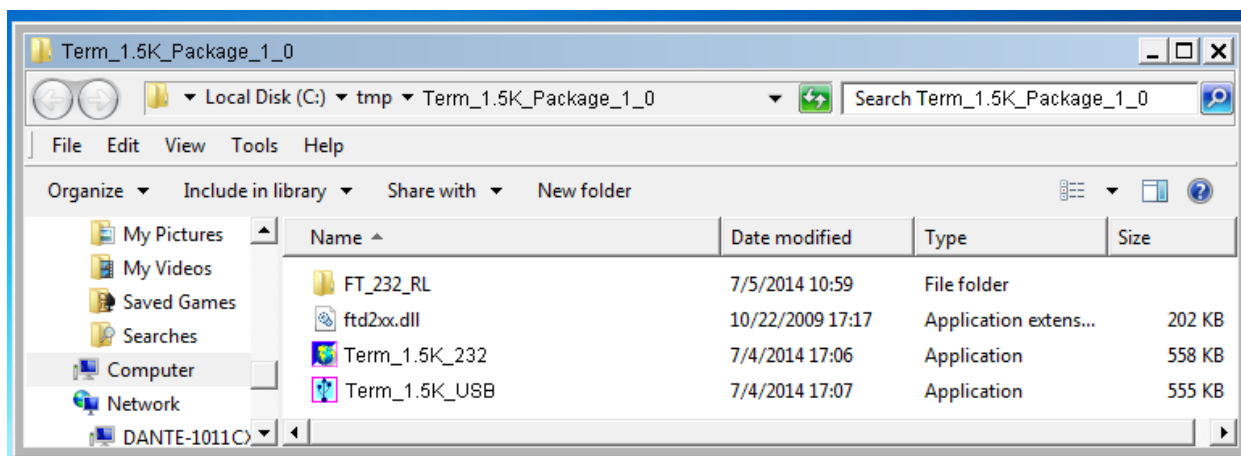

Where:

FT_232_RL is a folder containing the USB drivers and an automatic installation program, which must be run just once to prepare the operating environment which sorts out everything needed, such as the USB drivers and their support files on the Windows host system.

Term_1.5K_USB.exe is the remote control application that can be launched only after having installed the USB drivers properly.

ftd2xx.dll is a support library file for the **Term_1.5K_USB.exe** application. It must be accessible by **Term_1.5K_USB.exe** application, so it is required to be either manually copied into the same folder of the application or into another system-wide folder (e.g. **C:\Windows\System32**, which is one of the most used repositories for libraries and application support files).

Term_1.5K_232.exe is the remote control application specially designed to establish a connection using the devoted RS-232 serial port which is available on the rear panel of the linear amplifier. This application does not require any preparation related to FT_232_RL drivers, since it uses the proprietary Windows resources.

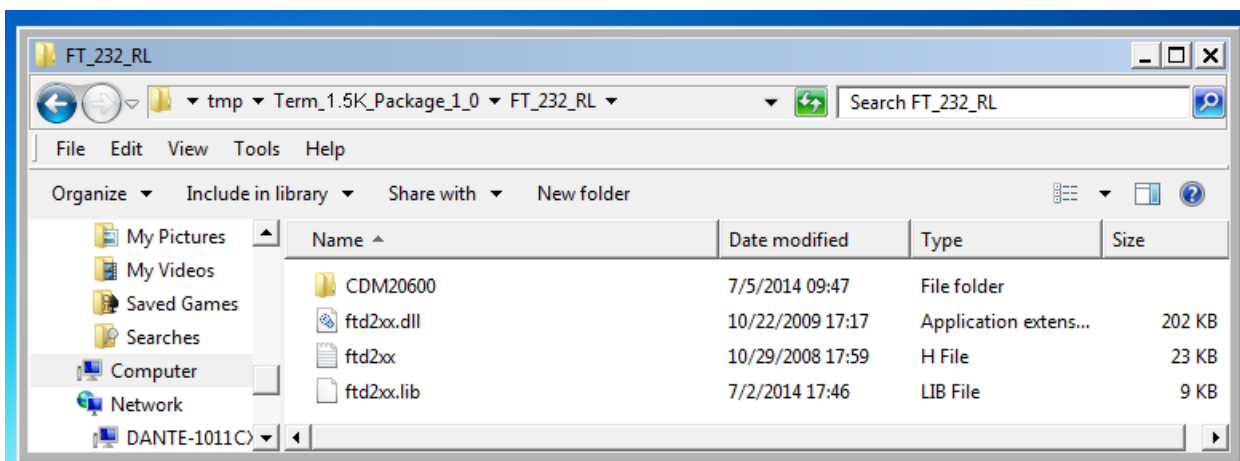

Once opened, **FT_232_RL** folder will show the above contents

A very important part of the installation procedure is the **CDM20600** folder, which contains among the other files, the **CDM20600.exe** Windows application as highlighted in the picture below:

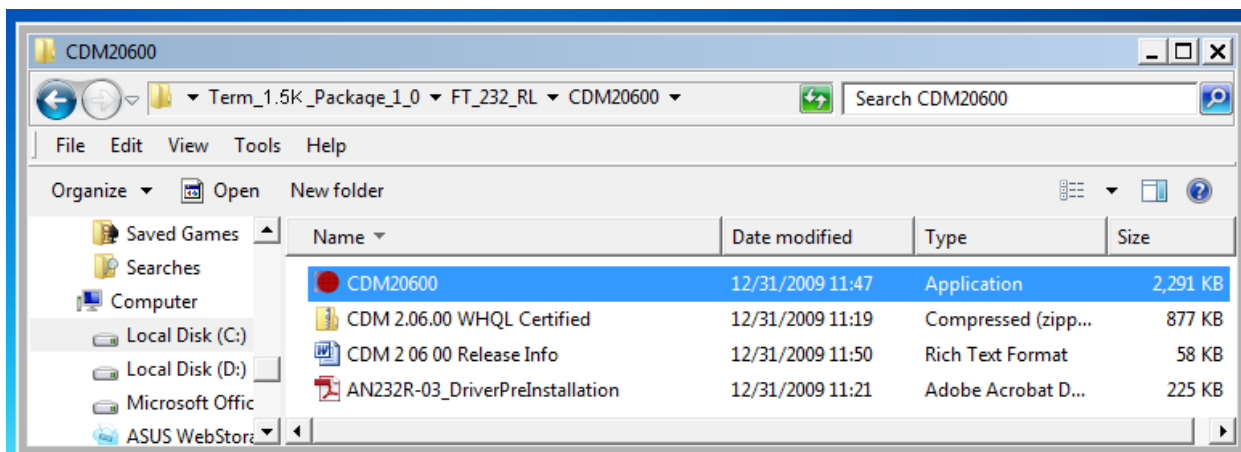

This application has been specially designed for a correct installation of the specific **FTDI** USB drivers.

So, **remove any physical link between the EXPERT 1.5K-FA and the PC for now.** Then double-click over the "red ball" icon of **CDM20600.exe** application and wait for its preparatory job to be completed.

As soon as **CDM20600.exe** starts running, a DOS window similar to the one shown in the following picture will pop-up for several seconds then disappearing after its automatic preparatory job is completed.

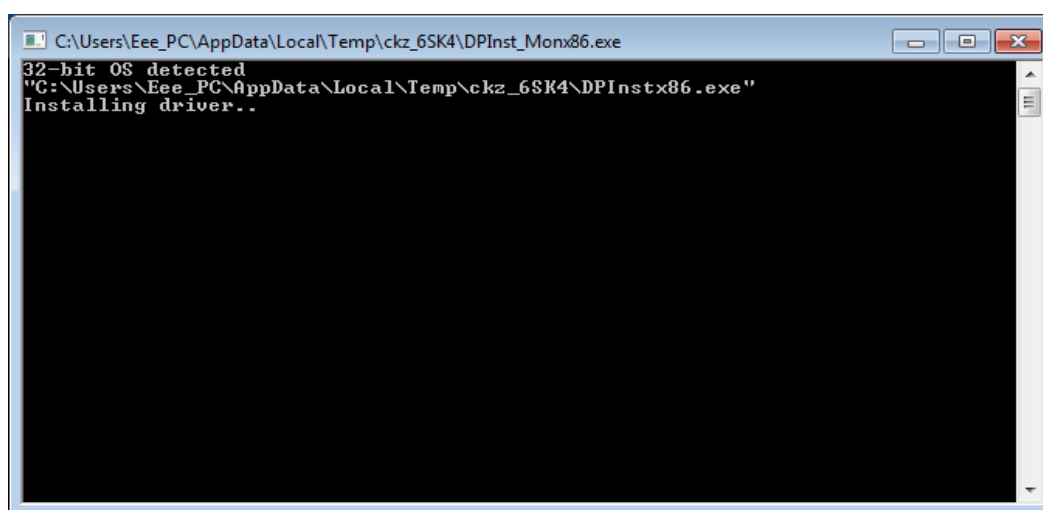

The next step is to connect the PC and the EXPERT 1.5K-FA by using the supplied USB cable and waiting for the identification of the newly created USB connection.

A notification window will pop-up as shown in the picture below

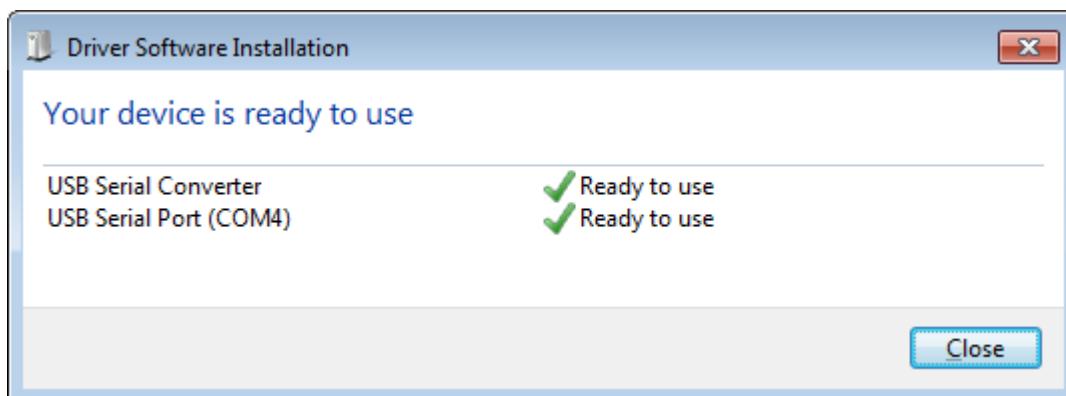

The USB port installation and its setting is now complete.

Now that this fundamental step has been successfully completed, the application **Term_1.5K_USB.exe** remote control application can be launched.

For this purpose a back-step to the starting uncompressed folder **Term_1.5K_Package_1_0** must be performed and double-click on the application filename, as indicated in the picture below

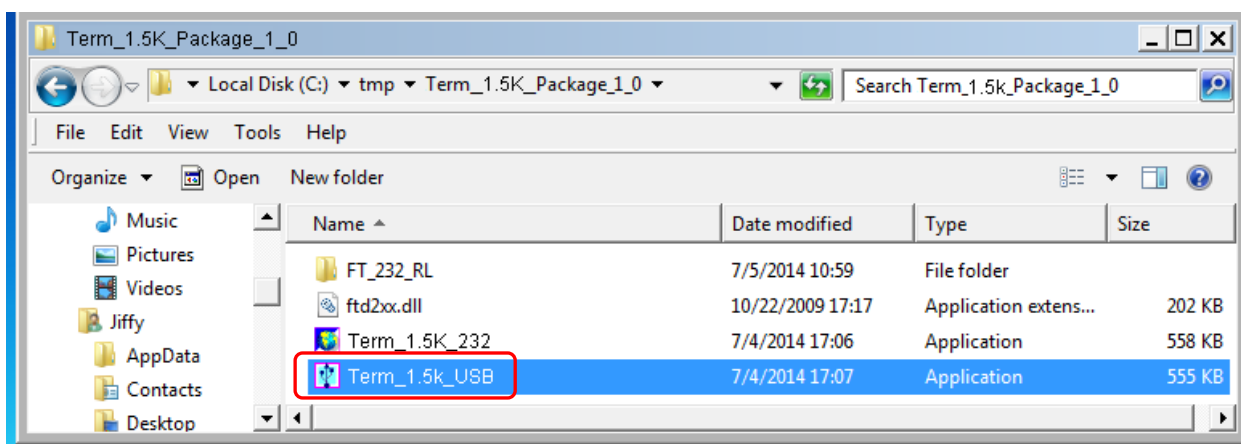

*Note: Do not forget that **Term_1.5K_USB.exe** requires full accessibility to the **ftd2xx.dll** application extension.*

So, in case the application itself gets copied into another work folder, please correct that action.

*A good practice is to copy both **Term_1.5K_USB.exe** and **ftd2xx.dll** into the same work folder.*

20.2 Term_1.5K_USB.exe usage

To test, connect the USB cable from the PC and the linear and double-click on the application's icon (the USB icon symbol), by using the mouse left-button, just to see if everything works fine.

It is a good idea to create a link to the application on the desktop.

As a result the applications main window will show up, as in the following picture:

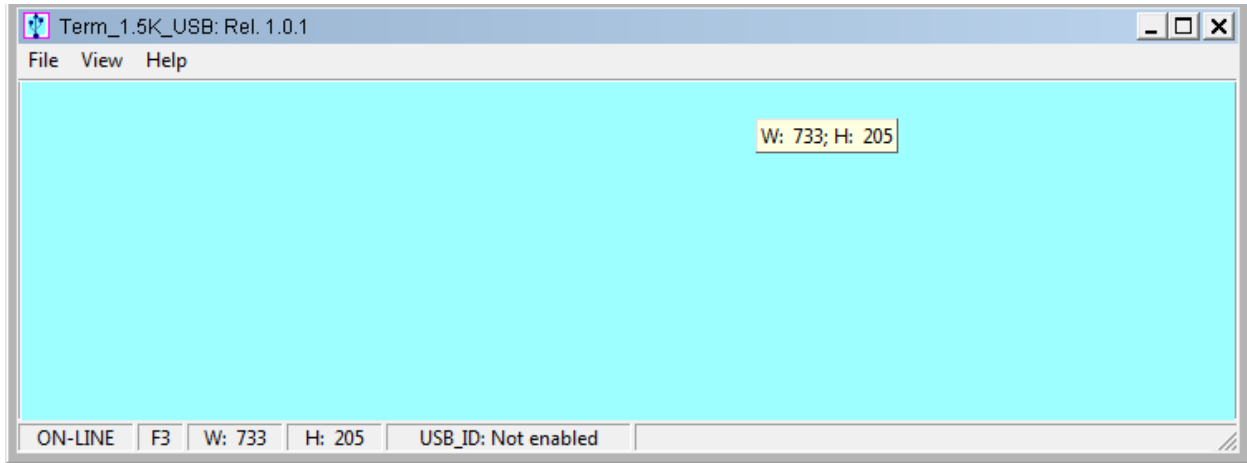

This is the main window of **Term_1.5K_USB.exe** application.

It is a realistic reproduction of the **EXPERT 1.5K-FA** LCD display, and it is also equipped with a pop-up virtual keypad having almost the same look and feel as the real keypad placed on the front panel of the linear amplifier.

To activate/deactivate this keypad the user must check/uncheck the **View/KeyPad On/Off** menu item as shown in the following screen snapshot:

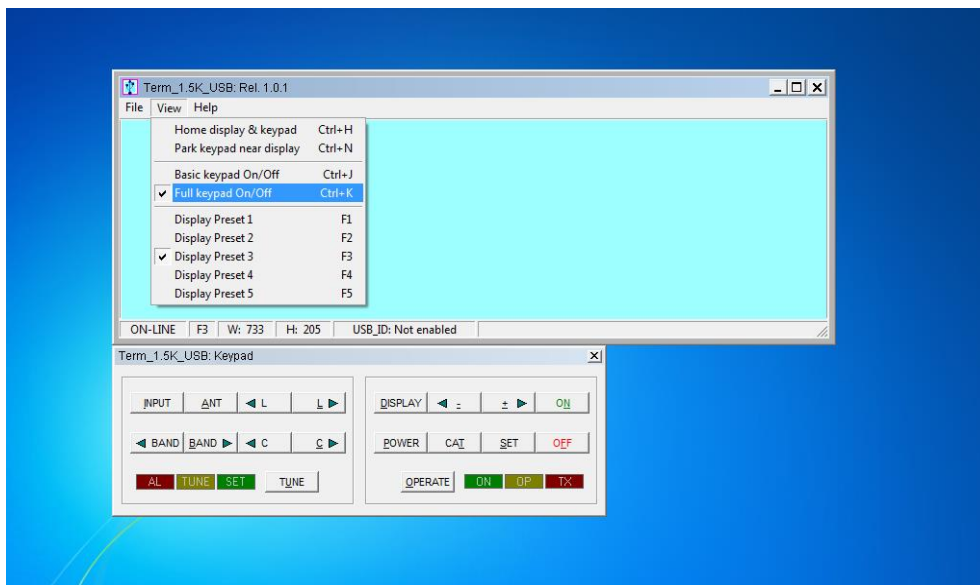

The **V**iew menu also contains five items related to the application window size presets which can be either selected by the menu itself or by their equivalent [**F1** ... **F5**] shortcut keys.

Feel free to test all the **V**iew menu options in order to find an optimal and comfortable vision of the display main window.

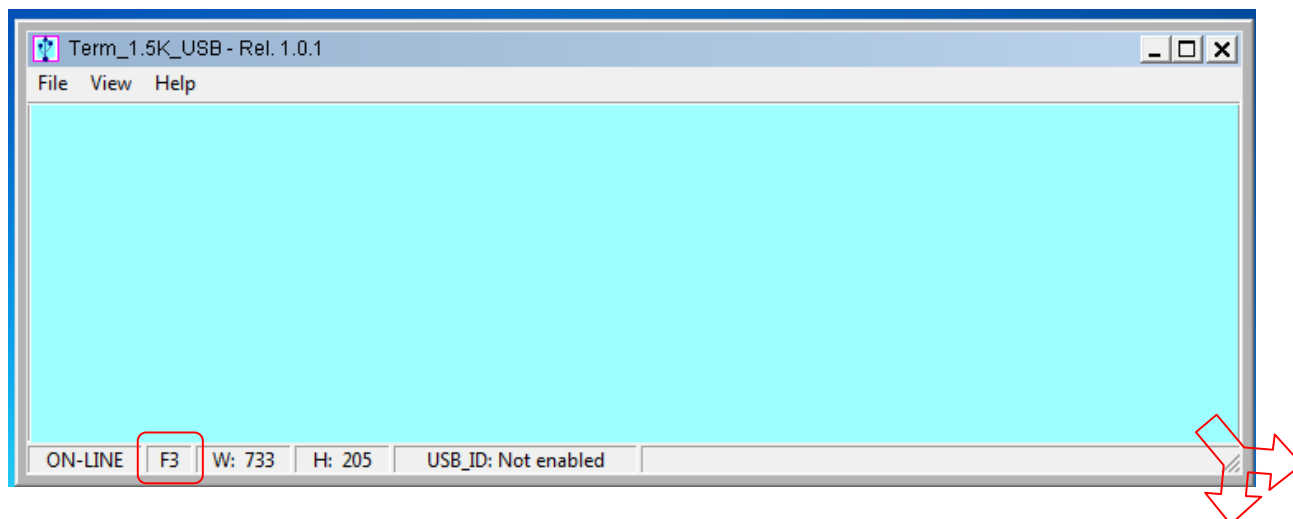

The display window can easily be resized. That is, either enlarged or reduced by acting on the right-bottom corner of the window. Also by using the mouse as shown in the picture above and in the same way as any other window-resizing operation.

In case the user wants to restore the original size-preset lying behind any [**F1**...**F5**] key, you must select the **Fx** preset and, then, press the **Ctrl+Fx** key combination on his PC keyboard.

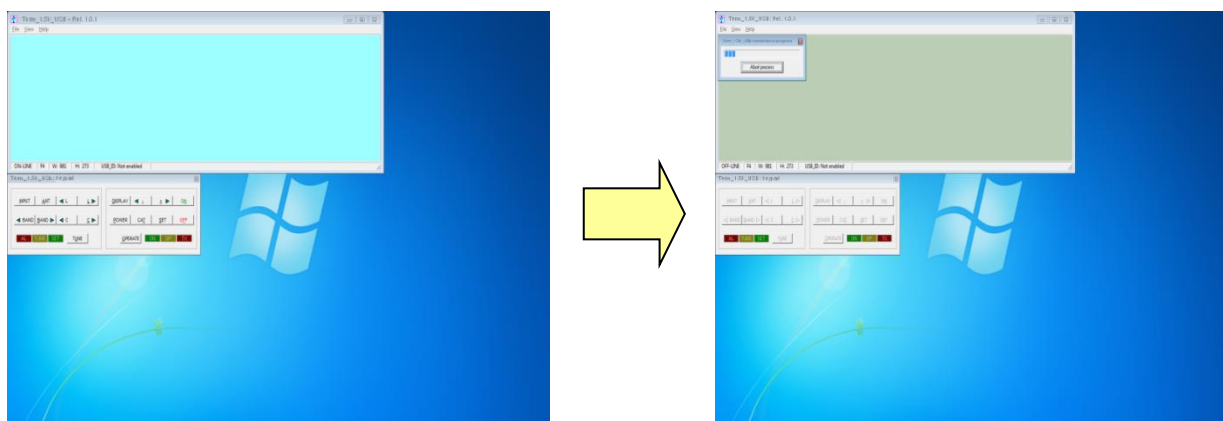

When **Term_1.5K_USB.exe** gets launched an automatic **Connect** command also starts and if a USB link to the linear amplifier was already active, it should have shown a result similar to the picture sequence above.

In case this doesn't happen, there's also a chance to try connecting by using the **File/Connect** menu item (or by using its equivalent **Ctrl+Q** shortcut key...).

The final visual result will be a "bright backlight" display and a function-keys enabling of the virtual keypad.

In case the **EXPERT** linear is already switched on, after the connection established by **Term_1.5K_USB.exe**, an immediate update on the current display contents will result. However, if the **EXPERT** linear was already switched off, it would be turned on by using the [ON] virtual key on the application keypad.

Similarly, all the other virtual keypad keys perform the same actions as their equivalent mechanical keys forming the real front panel keyboard of the **EXPERT 1.5K-FA**.

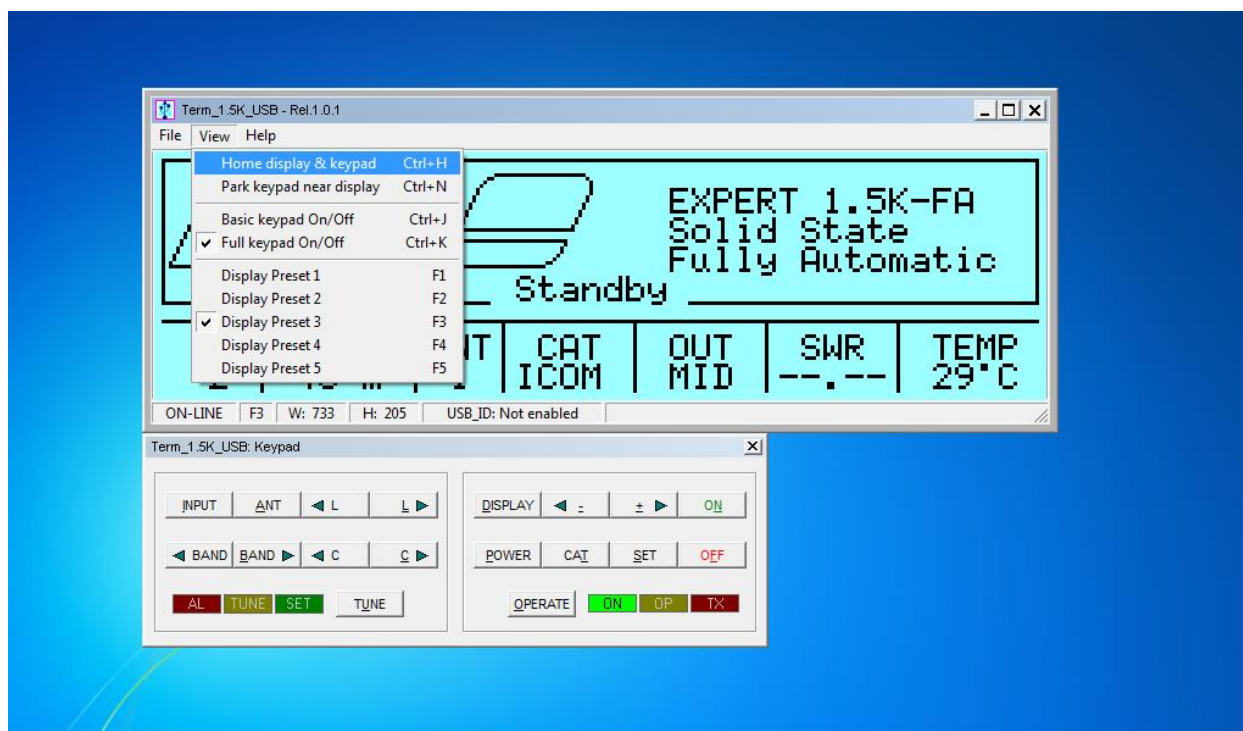

The **View** menu is also equipped with the useful **Home...** and **Park...** items which have been specially designed to allow an automatic repositioning of the application along the PC desktop area.

In more detail:

- **Home... (Ctrl+H)** This item positions the display window to the upper-left corner of the desktop area and aligns the keypad to its bottom edge.
- **Park... (Ctrl+N)** This item leaves the display window where it currently stays and just aligns the keypad to its bottom edge.

The above described operations could be helpful whenever a quick and safe repositioning of the application windows is desired.

The **Basic keypad...** item in **View** menu allows you to set to a reduced-size keypad, having fewer keys than the complete keypad, which could be useful when no setting actions are required on the linear amplifier.

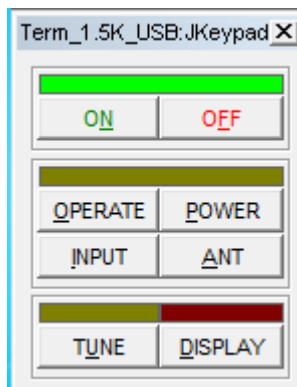

Note: The keypad types, both Full and Basic, are certainly very useful since they both can be directly accessed using the mouse pointer. It is helpful to know that all the operations allowed using the virtual keys can be also performed using short commands directly typed on the PC keyboard.

The following one is the “shortcut-keys” table:

1.5K-FA Function key	Equivalent shortcut-key from the PC keyboard
[INPUT]	I
[ANT]	A
[<L]	Ctrl+L
[L>]	L
[<BAND]	Ctrl+B
[BAND>]	B
[<C]	Ctrl+C
[C>]	C
[TUNE]	U
[DISPLAY]	D
[< -]	-
[> +]	+
[ON]	N
[POWER]	P
[CAT]	T
[SET]	S
[OFF] (*)	F
[OPERATE]	O

Please bear in mind that the [OFF] command as accessed from the virtual keypad or by shortcut key, that it always asks for a confirmation, to its amplifier shutdown operation, by showing the dialog form below:

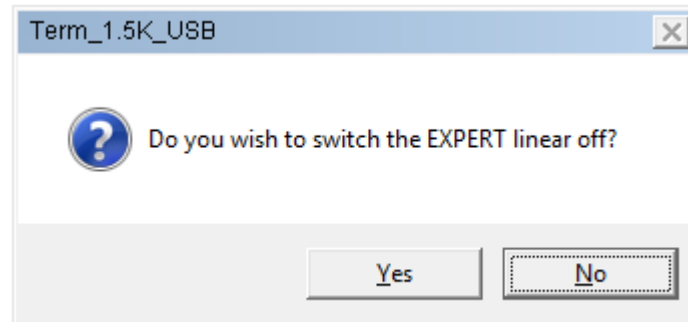

When trying to connect the linear amplifier to a PC, some problems could occur because other peripherals sharing the same USB internal hub may conflict with it. To avoid this kind of conflict it is necessary to go to “selective addressing”.

Selective addressing thru the USB port.

This options has been designed to allow selective addressing of an EXPERT linear amplifier connected to any given PC USB port.

In contrast to similar devices using the popular FT232RL USB microcontroller where the typical way for providing selective addressing of a specific device is based upon its serial port ID parameter (e.g. COM1, COM2, etc.), our method is based upon a unique feature of the popular **FTDI** chip that is known as “**ID String Property**”.

That is a sequence of 8-alphanumeric characters, programmed by the FT232RL’s manufacturer during the production process of their components, which is something similar to the MAC address typical to any PC LAN card.

It is important to understand that this unique coding parameter does not allow addressing ambiguity when correctly applied to FDTI chips that are connected to the same USB bus.

Preliminary programming for “ID string property” with Term_1.5K_USB.exe .

This special setting, based upon an easy “self-learning” procedure, must be performed once, however only after having put the Expert 1.5K-FA into an **OFF-LINE** state.

Then, select **File/Configure USB connection...** from the main menu as shown in the picture below:

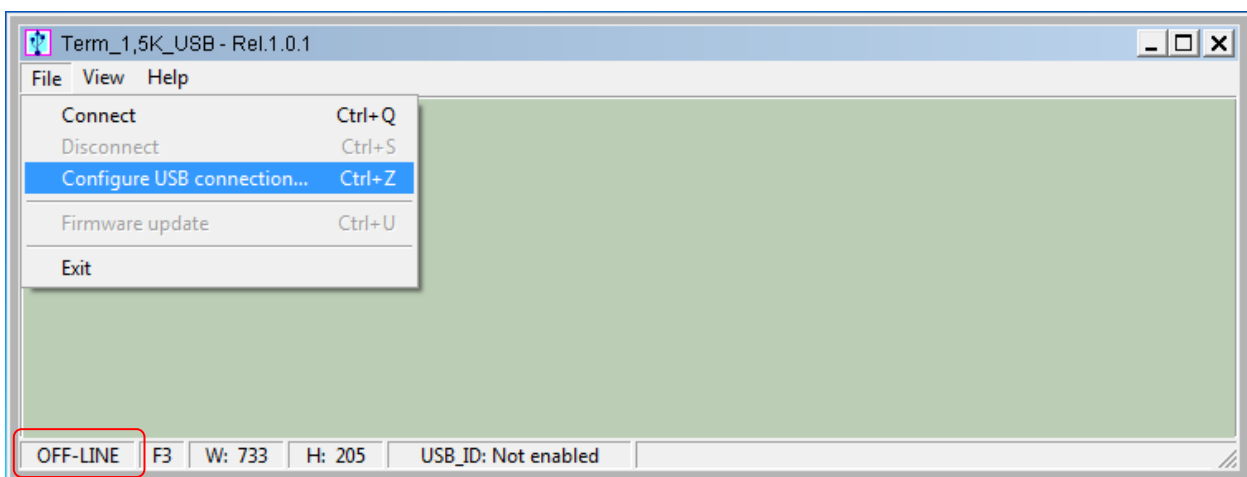

A dialog window will pop up:

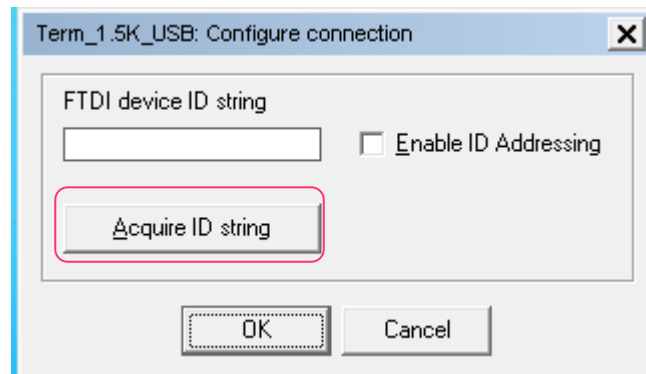

Press the **Acquire ID string** key, marked in the picture above, in order to start the **ID string** characters acquisition process across the USB data-link.

This is a guided self-learning procedure.

In case more than one USB communications is linked to the system, directly or indirectly thru an external USB hub, the following notification pop-up window will be shown:

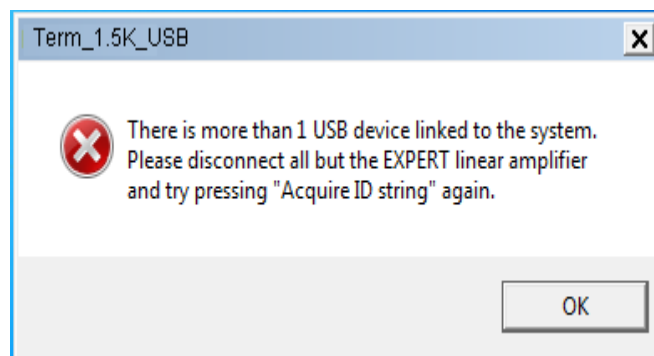

In such a case the user should disconnect all other devices except the EXPERT amplifier and to retry again using the acquisition procedure above described.

In case the user detaches all of the connected devices, including the linear amplifier, the **Term_1.5K_USB.exe** acquisition system will notify the user by showing the following self-explaining pop-up message.

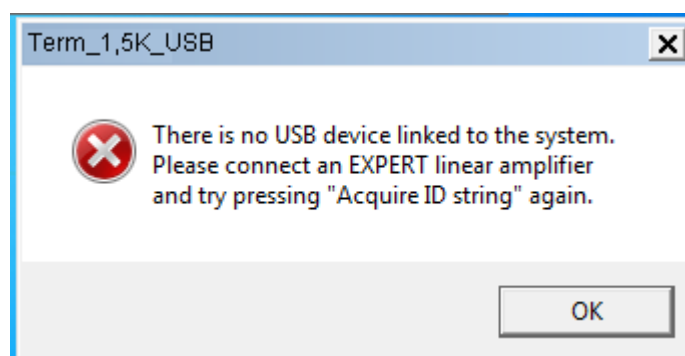

The following pop-up notification message will be displayed when a successful connection via USB occurs:

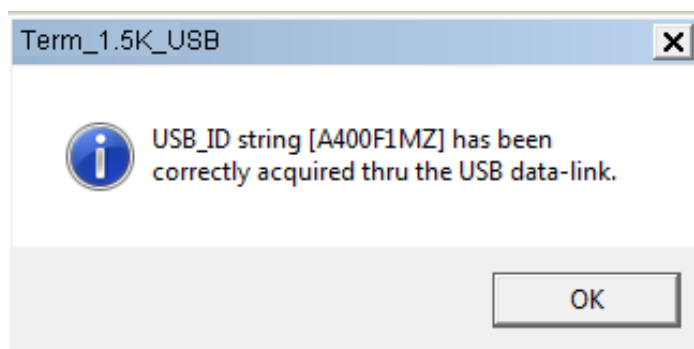

The picture above shows the acquisition report of a device that its **ID String Property** is **A400F1MZ**.

As explained earlier, this parameter is unique to any given specific chip, so it doesn't allow duplicates among other components from the same manufacture.

As soon as the notification message is validated, using its OK key, the dialog box previously popped-up will appear properly filled-in as the following picture shows:

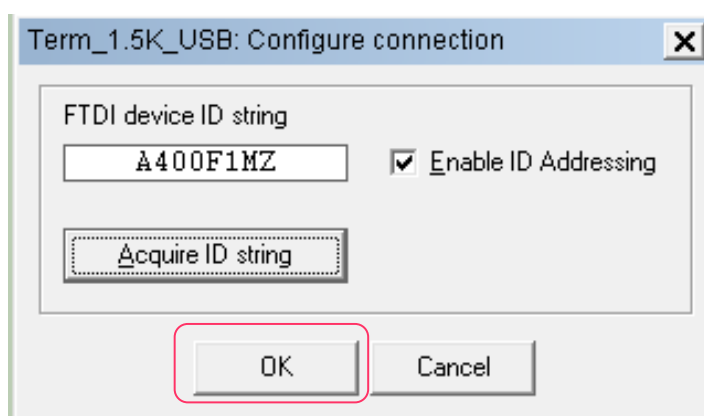

Once the user validates the data acquisition, by pressing the OK key as marked in the picture above, the **Term_1.5K_USB.exe** internal database will be properly updated and as confirmation, the application status bar will be updated, as shown in the following picture:

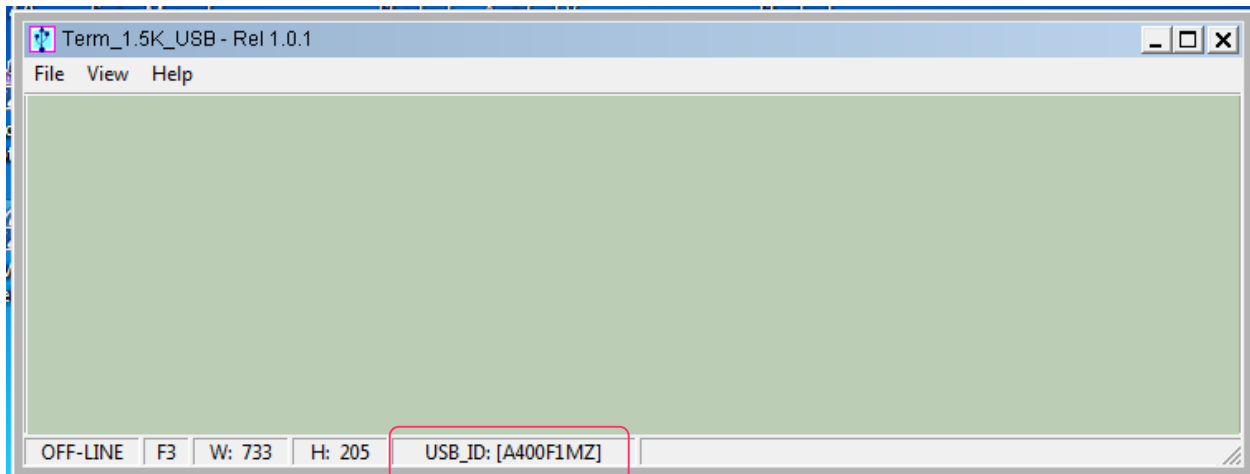

When the above described steps are completed, **Term_1.5K_USB.exe** will only be able to recognize and address the **EXPERT** linear amplifier whose unique **ID String** matches the one written after the **USB_ID:** label of the picture above.

As explained earlier, this setting is permanent. So there is absolutely no need to repeat the acquisition procedure described as long as the user connects to that specific unit.

Of course the acquisition procedure must be restarted again in the case of another **EXPERT** linear amplifier be required to be addressed in the same selective way; this is because a different device has acquired, by force of circumstances, another **ID String** parameter to be reconsidered.

After having carried out all the setting and configuration steps listed in the earlier pages, you should be all set for using the FT232RL selective addressing features as described so far.

All the operations tied to the **C**onnect / **D**isconnect menu items are still the same as in the case of the non-selective addressing procedure.

A last note.

If, for whatever reason, all the selective addressing capabilities are no longer needed, to open a connection to an EXPERT linear thru its USB link, they can be temporarily disabled.

The next operation is quite easy to perform.

After having recalled the **Configure USB connection** dialog box, using its specific item contained into the **File** menu, using your mouse click on the **Enable ID Addressing** option, as shown in the following picture, and confirm this entry using the **OK** button.

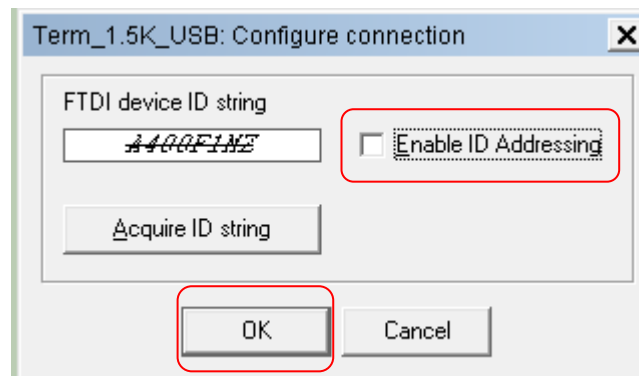

You will see this new setting in the application status bar with the **"Not enabled"** attribute following the **USB_ID:** label, as shown below:

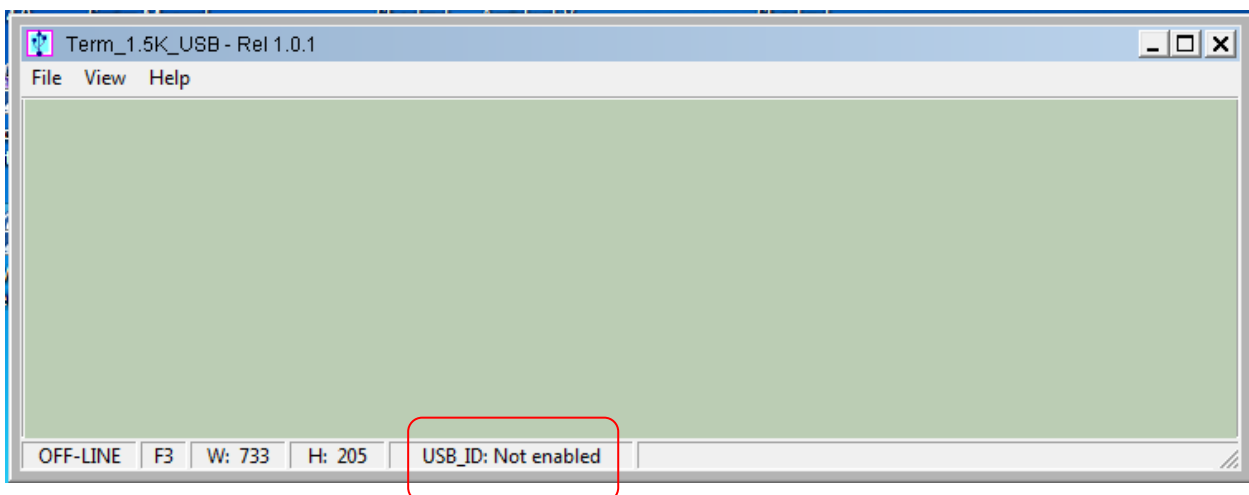

20.3 Term_1.5K_232.exe usage

To start running the **Term_1.5K_232.exe** application, it is necessary to go back into the **Term_1.5K_Package_1_0** uncompressed folder and select the related filename as shown in the picture below:

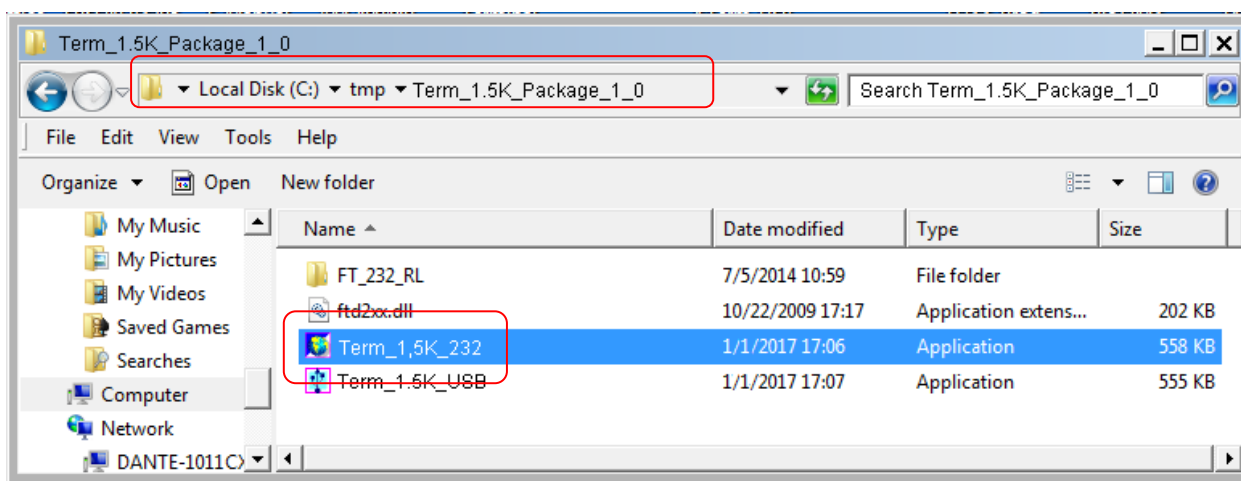

A suggestion is to create a link to the application and place it on the Windows desktop. A double-click using the left-button of the mouse on the application icon should render a result as the one shown in the following picture:

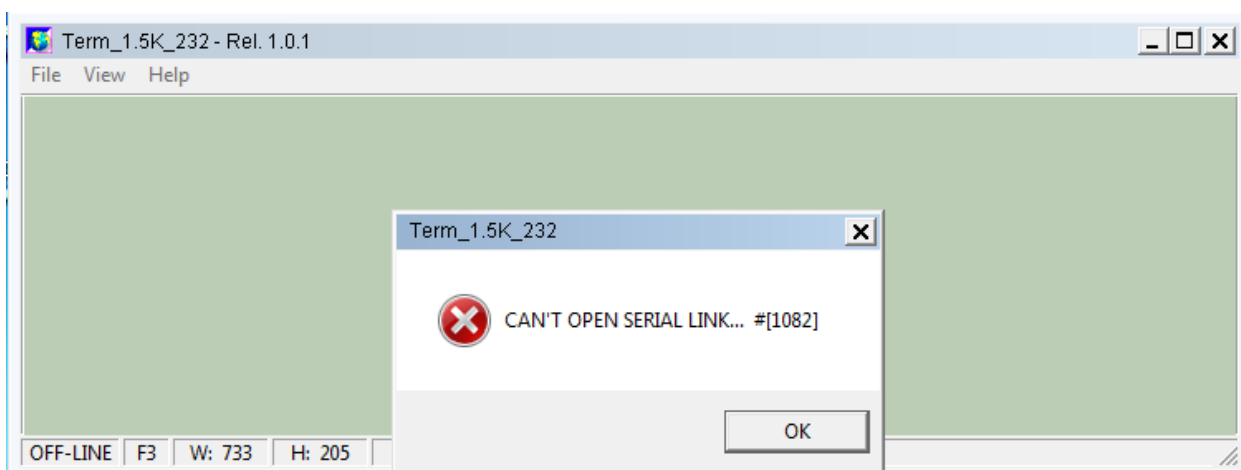

The very first time **Term_1.5K_232.exe** is launched, a notifying pop-up message, like the one in the picture above, is shown.

This is for just warning the user that there is still no valid RS-232 port being set on the application itself.

To correct this, click OK on the pop-up window and select **File/Virtual Com Port setting**, as shown in the following picture:

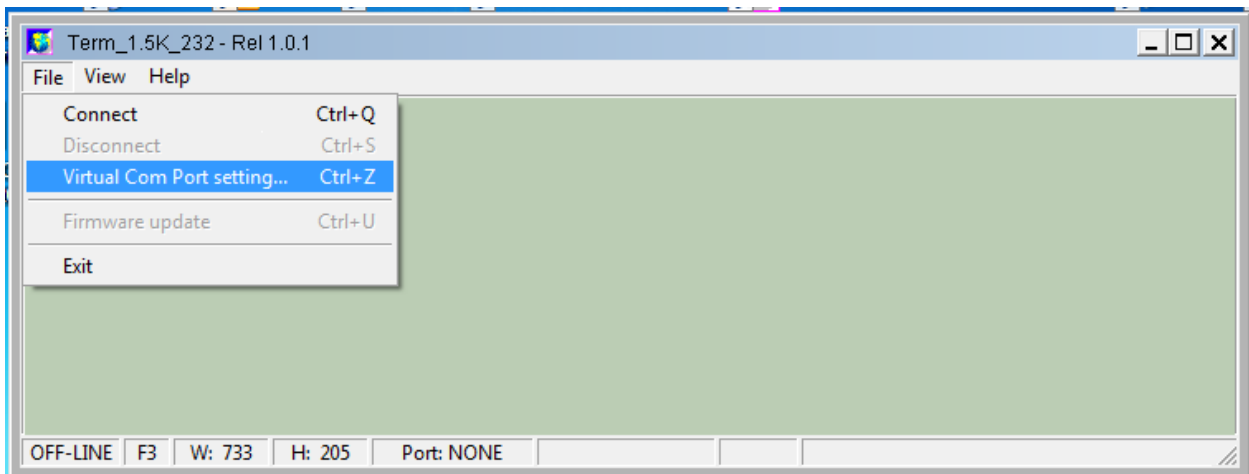

The above menu item makes it possible to access the following dialog box, which allows a direct setting of the desired **COMx** serial port for connecting to the **EXPERT 1.5K-FA**.

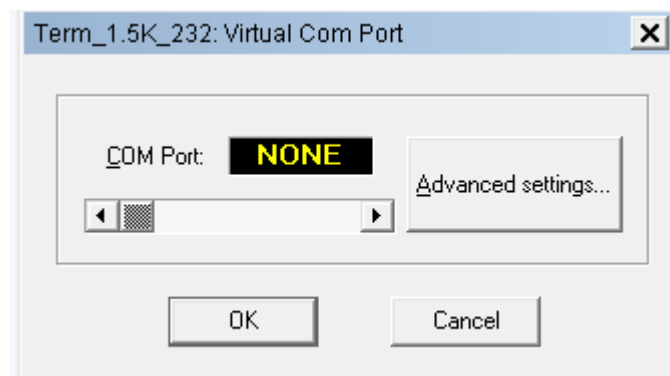

If the number of an unused COM is unknown, proceed as the following page.

With all your serial resources properly connected, proceed to the **Control Panel >>> Hardware and Sound >>> Device Manager** and choose a serial COM listed in the hardware configuration that is not used by other applications.

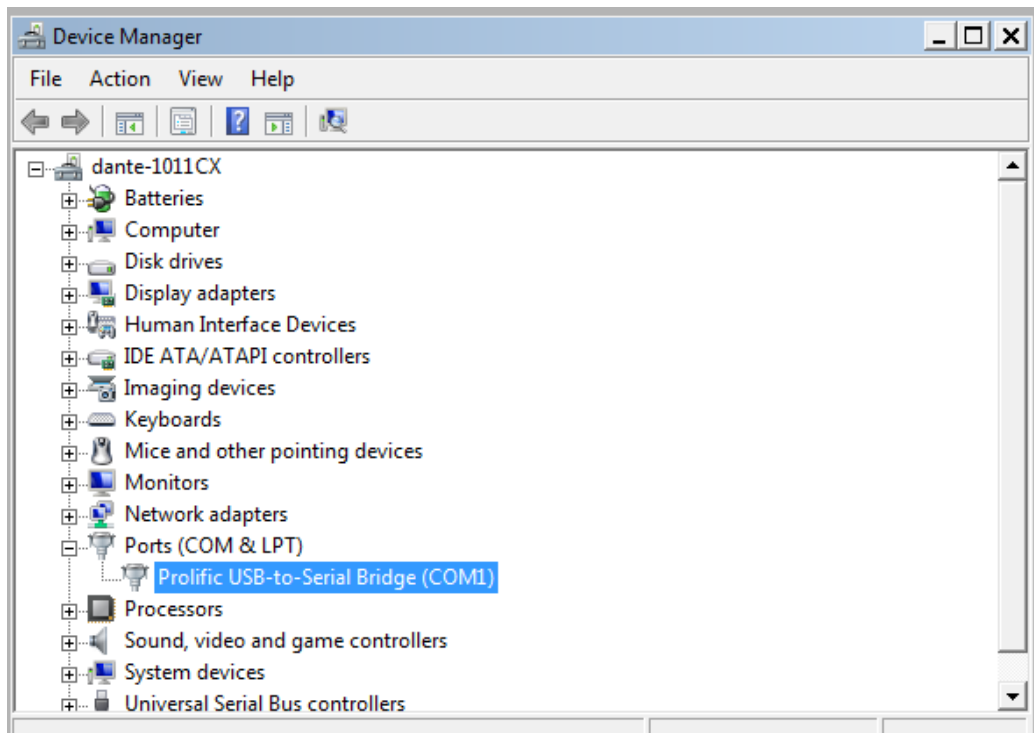
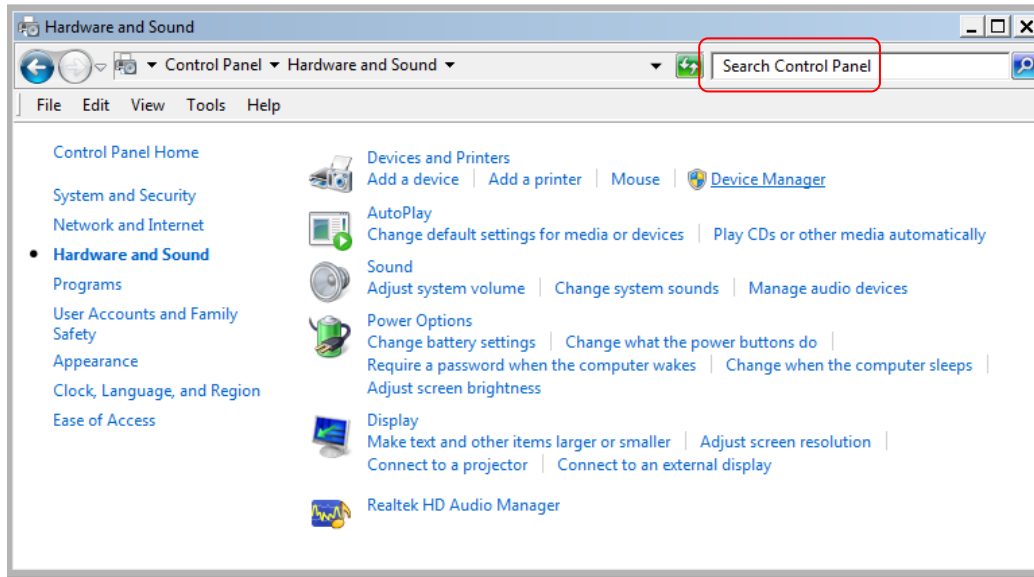

In the case that USB-to-RS232 serial converters are being used, as shown in the picture above, please proceed, as explained below, to check all the COM ports polled by the system.

To check a **COM** port identifier related to any given adapter, disconnect it from the USB socket of the PC and detect which **COM** item disappears from the proposed list after this configuration change.

In that case, use the detached COM port ID to properly set the **Virtual Com Port** dialog box, as shown in the picture below, and then reconnect the serial adapter so that it can be accessed by the application.

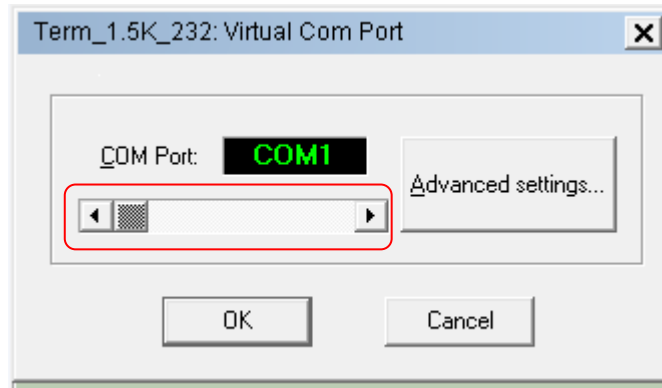

The available selection range spans thru the [**COM1...COM256**] set, which can be accessed using the framed slider-control placed above the OK and CANCEL keys.

After the COM port setting is validated by pressing the OK key, all the other communication parameters become set as follows:

- **Baud rate: 115200**
- **Bit per character: 8**
- **Parity check: No**
- **Stop bit: 1**

Also, the Baud-rate setting can be changed by pressing the **Advanced settings...** if needed.

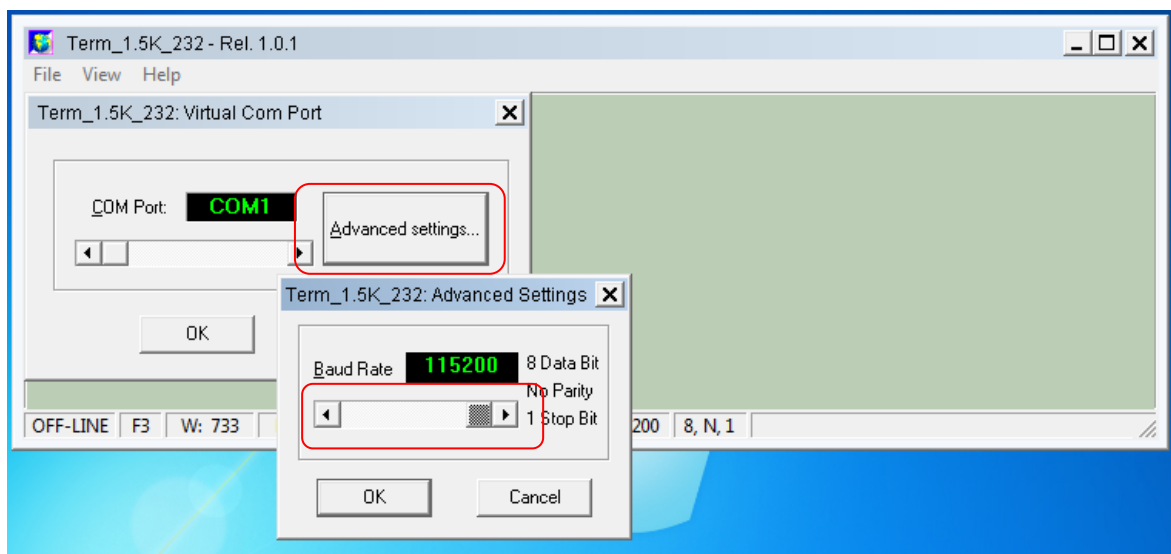

The **Baud rate** setting can be selected by using the available slider-control marked in the picture above:

- **9600 baud**
- **14400 baud**
- **19200 baud**
- **28800 baud**
- **38400 baud**
- **57600 baud**
- **115200 baud**

And then by pressing the **OK** button.

All the other framing and parity parameters cannot be changed by the user because they are set by the program initialization.

It should be noted that the **Baud rate** setting has to be set on the **Term_1.5K_232.exe** application's side before a remote connection can be made.

And it may need to be changed due to a previous setting of a different baud rate.

The reason for this is because it is a permanent setting, which is stored into a private data-base system, and will be recalled by the application whenever needed.

On the **EXPERT 1.5K-FA** side, the baud-rate is automatically synchronized by the data-pattern being sent to it by **Term_1.5K_232.exe** upon any query to the linear.

As mentioned above, the application usage is still the same as for the USB interface version described earlier, but there are just some minor “look-and-feel” changes as shown in the picture below:

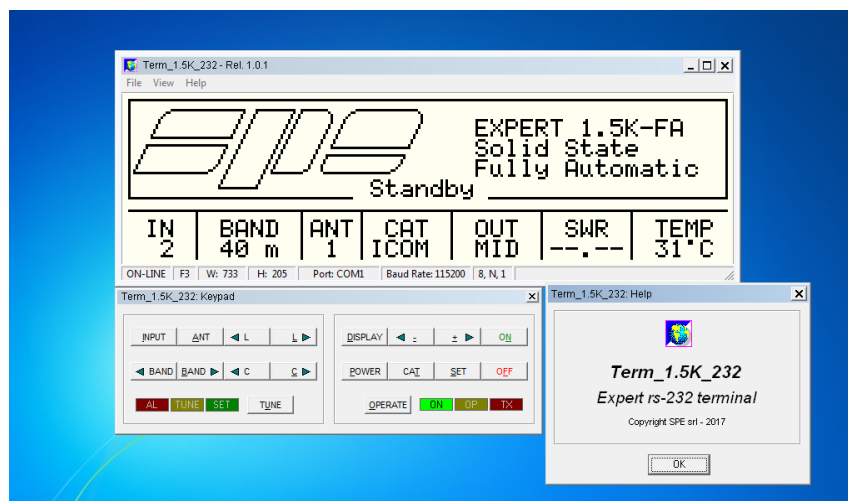

The use of RS 232 port becomes a necessity when the device needs to be remotely controlled via the Internet. And since most specially designed devices, currently available on the market, do not implement the USB port feature to being compliant to the USB front-end of the EXPERT linear amplifiers.

Remote ON/OFF using RS-232.

With this new software release, the **[ON]** and **[OFF]** keys are fully enabled and work the same way as they work on the USB version of the application.

However, there is a small technical detail to take into account about the **[ON]** key's behaviour.

Since the "PORT" connector on the rear panel of the amplifier is not equipped with any DSR, the DTR output of the PC's RS-232 port is used to activate the [ON] function, which generates a timed positive pulse about every second.

This pulse, duly integrated, is injected into the "Remote ON" pin of one of the two CAT connectors according to the following diagram

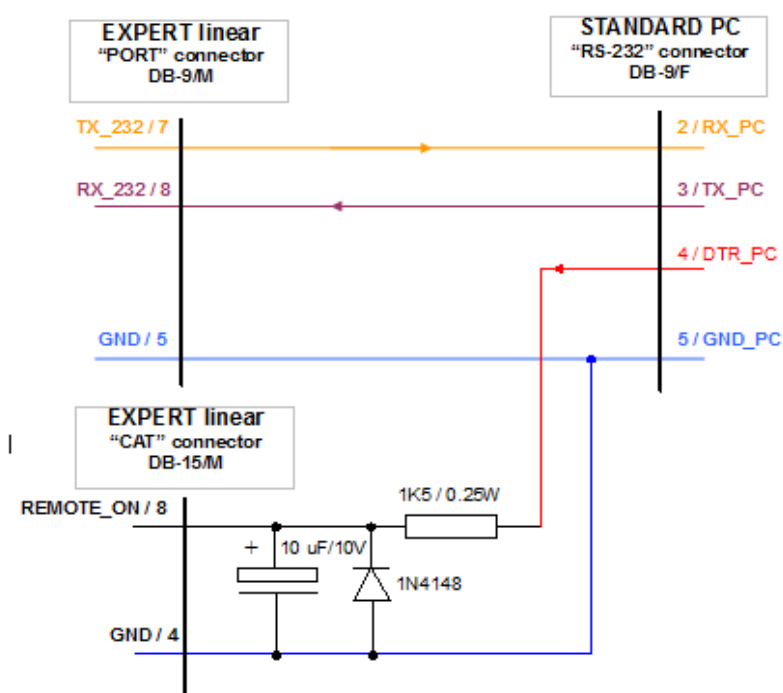

Cable with which you can control, turn on and turn off the amplifier using the RS 232 port

A note about the DTR-link behaviour.

Even though this circuit seems to work correctly when driven by software, it could cause unexpected switching-on of a connected linear amplifier having its rear panel's mains-switch enabled, when the linked PC re-boots or when an external serial device (e.g. a USB to serial adaptor...) is physically connected.

The reason for this odd behaviour is related to some uncontrolled OFF-to-ON transitions of a DTR output line.

So, please, take this unpleasant side effect into account when using this kind of branch in external links.

20.4 Firmware update

A very useful feature of the **Term_1.5K_USB.exe / Term_1.5K_232.exe** applications is one that enables software updating of the built-in firmware in the linear amplifier.

To update the linear amplifier it is necessary to use a suitable **.PK4** firmware file, which must be downloaded from our website www.linear-amplifier.com and then stored into a proper working folder.

Switch the linear on leaving it set to the **STANDBY** mode during the firmware updating.

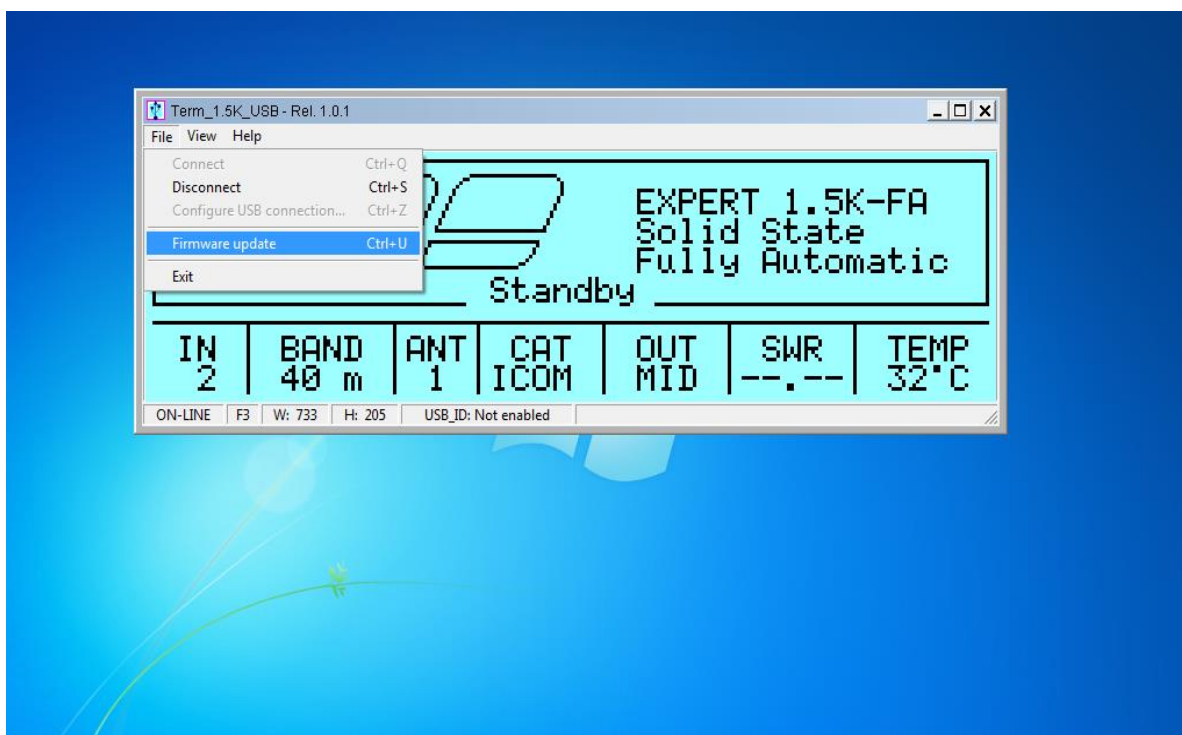

Under these conditions the **File\Firmware update** menu item becomes active and, after being selected, it sets the **EXPERT 1.5K-FA** into its firmware update mode (**FIRMWARE UPDATE PROCEDURE**).

Pressing [CAT] key twice, the current software revision is shown.

NOTE: It is highly recommended that prior to carrying out a firmware update, that all cabling except the AC power and USB cable, are disconnected from the SPE.

After that a dialog box pops-up, and the user must select a proper firmware package, that data will be sent to the linear amplifier to update all its embedded functions

Note the example in the picture below where a firmware package file named **1.5k_01_01_17_A.pk4** has been selected:

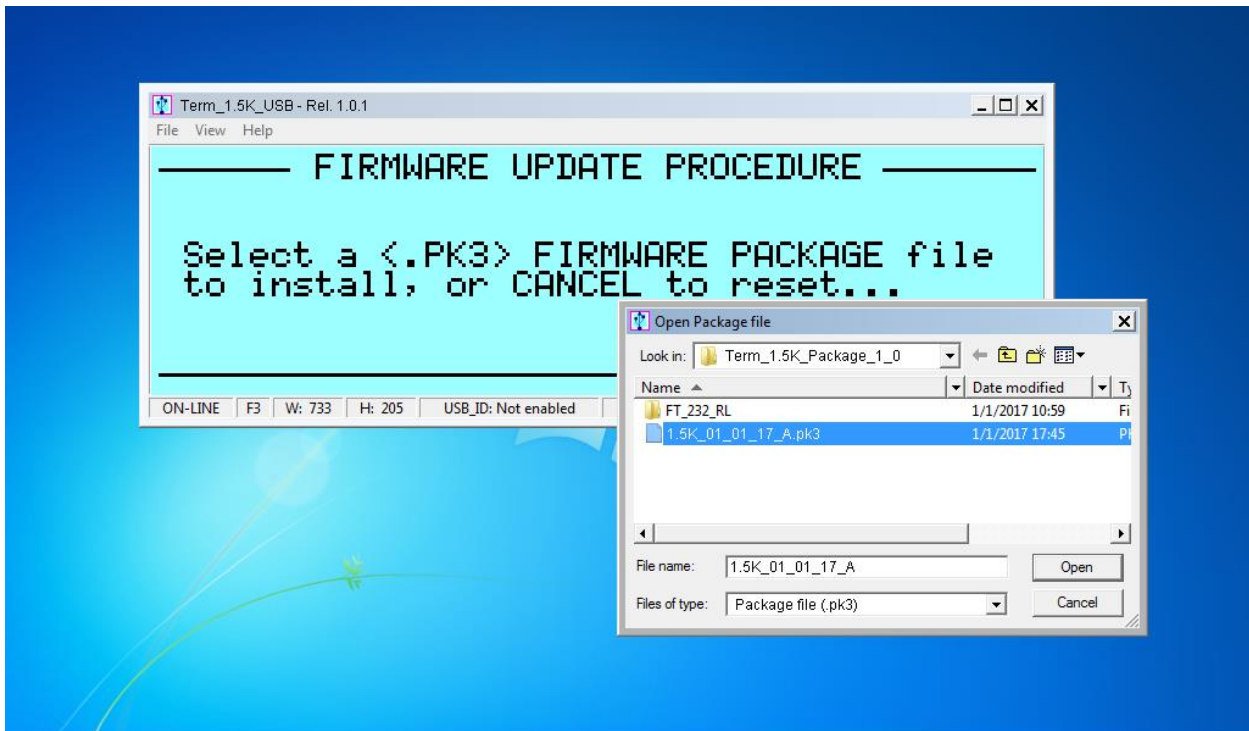

After the necessary confirmation by the user for validating the procedure, the **EXPERT 1.5K-FA** switches its display off as the updating is being transferred to the **Term_1.5K_USB.exe** application

The main steps of the firmware update procedure are below:

- Checking and validation of updating firmware package.

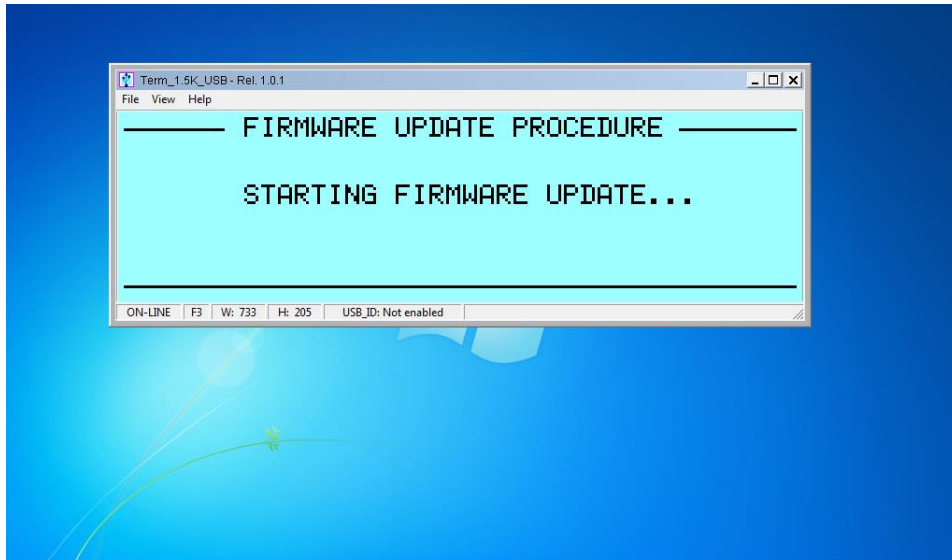

- A physical data transmission of the new firmware from the PC to the linear amplifier.

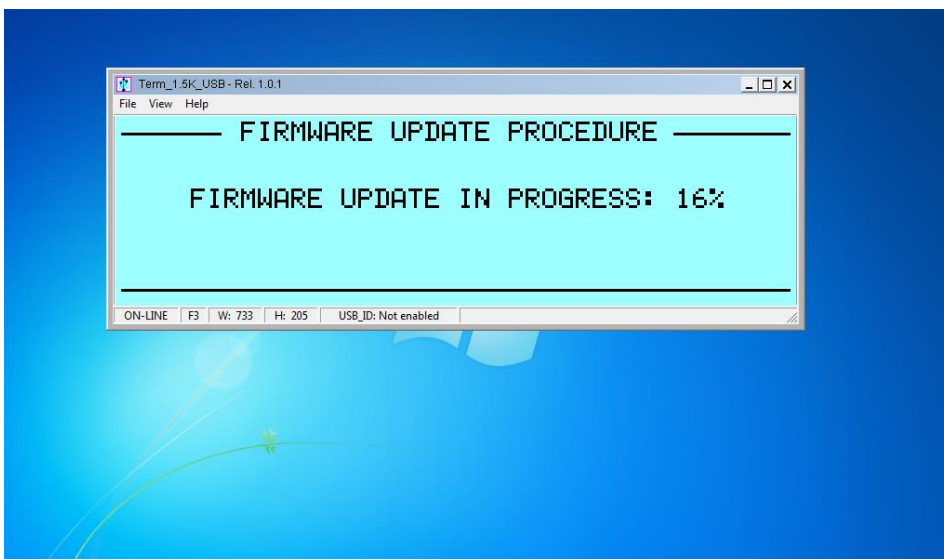

- A final validation for the completed firmware update.

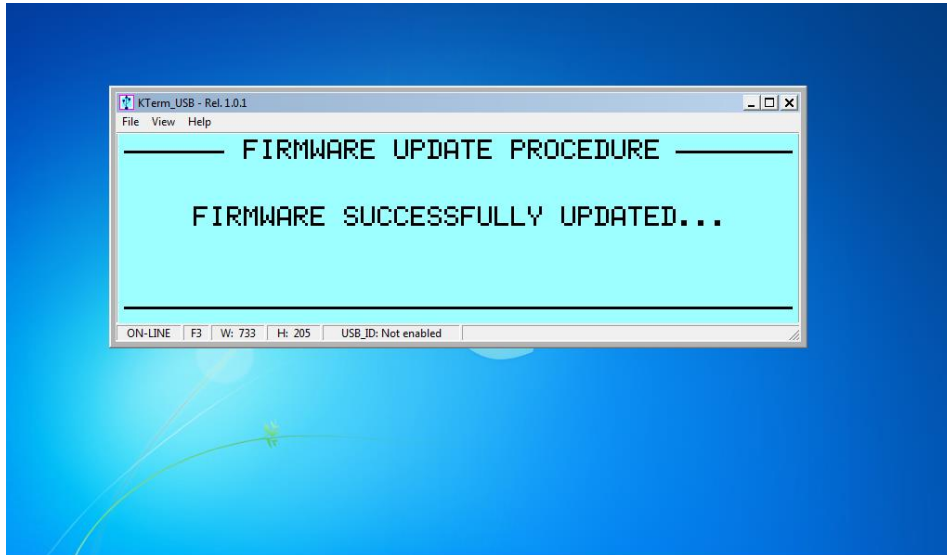

And as the last action, after a successful firmware update, the linear amplifier performs a general auto-restart operation. Then full control of the updated device is restored to both local and remote operations.

The user is then able to check the result of his firmware update operation directly on the LCD display (both real and virtual...) by pressing the [CAT] key twice and only when in the **STANDBY** mode.

This operation will be shown on the display as below:

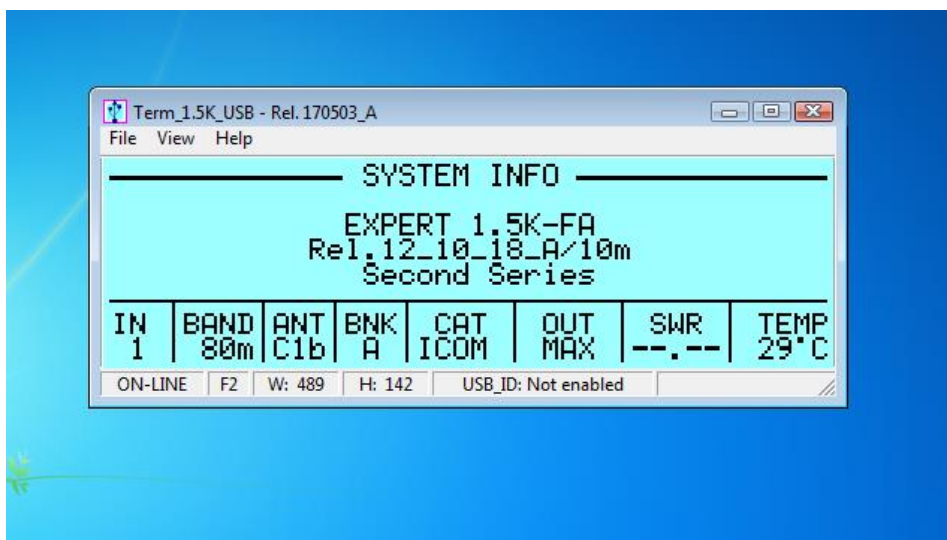

21. GENERAL RESTORE

A System General Restore can be performed by pressing the [**INPUT**] and the [**OFF**] keys together for at least one second.

This operation is only possible from the linear amplifier front-panel physical keyboard.

The linear amplifier will switch off with a self-explaining system message.

Then, after it turns back on, all of the factory defaults will be restored.

22. WARRANTY TERMS

For a period of two (2) years from the invoice date, the Distributors warrant in the EU, at authorized laboratories, the free repair of manufacturing defects and the free replacement of defective components.

Each power MOS is guaranteed for the first 3 months and for a single replacement.

The warranty is not applicable in the cases specified below.

The Purchaser only has to pay all the shipping expenses in both directions.

Distributors outside the EU must comply with the current laws of the Country in which operate. If there is conflict with EU rules, they must post on their web site the relevant, modified “Warranty Terms”.

Customers should address requests for warranty service work to the Distributor/Dealer where they made their purchase.

As part of their reseller agreement with SPE, they are fully responsible for service support. If the Distributor/Dealer has closed down and if he is not replaced, SPE will be directly responsible for warranty service at their factory in Rome. The shipping expenses to and from SPE will then be paid by the customer. Any repair requests to other dealers / repairer will be subject to specific direct negotiations between the customer and the dealer / repairer.

In order to not invalidate the warranty service, the original Purchaser must complete the warranty registration card, and send it to SPE within 30 days from the date of purchase. Unless otherwise agreed, the products will be delivered ex-works from the factory of the seller.

The delivery, even in the event of a return for repair, is understood done with the delivery of the goods to the carrier specified by the purchaser or, failing that, to the carrier chosen by SPE or the Distributor/Dealer.

The products will travel at the risk of the purchaser even if, at the request of the same one or for other causes, SPE should carry out transport or choose the carrier.

If the original Purchaser finds some defects after having received the equipment, he must immediately notify the Distributor/Dealer of the defects found by sending the completed REPAIR FORM. Replacement of the amplifier may be offered by SPE in exceptional circumstances only and at SPE's complete discretion. However, no replacement will be offered after 21 days of original purchase.

In case of a purchase of a used amplifier, in order to retain the warranty's validity, it is necessary to notify SPE of the following data:

Document for the second purchase (used)

Invoice for the original purchase

Serial number (s/n) of equipment

Replacement of equipment in these circumstances is not an option.

In any case the warranty period shall be as specified from the date of original purchase, and not from any subsequent purchase. However, the limitation for MOS remains as outlined above, ie. the warranty period for the LDMOS device/s is limited to three months only. If the LDMOS has been damaged due to incorrect usage, it is not covered under warranty.

Whenever the date of the first sale is not well specified, the date of shipping from SPE to the Distributor/Dealer will be considered the start of the warranty period.

The warranty does not apply either if the certificate of the first purchase (invoice) is missing, the s/n is undecipherable / falsified or to any defect that SPE determines is due to the following:

1. Improper maintenance or repair by persons not authorised by SPE to carry out such work, including the installation of parts or accessories that do not conform to the quality and specifications of the original parts.
2. Acts of nature such as lightning, storm & tempest, moisture or water intrusion, fire.
3. Misuse, abuse, neglect or improper installation, user's manual non-observance.
4. Carelessness, accidental or intentional damage.
5. In the manual of the transceiver used it is clearly written that it cannot be used with a solid state amplifier.

In addition and more specifically possible damage caused by incorrect usage such as:

- Exceeding power ratings of antennas, insufficient impedance transformers and insufficient baluns.
- RFI in the shack.
- Low gate isolation due to the spike of the transceiver.
- Repeated input overdriving alarms.
- Repeated high SWR alarms.

SPE warrants only manufacturing defects and defects in the materials used, NOT inherent and consequent damages.

It is mandatory, when sending SPE equipment to be repaired, to enclose:

- Invoice of the original purchase.
- Document of the second purchase (if any).

Particular agreements between retailer and Purchaser or particular obligations imposed in other countries are matters for the local retailer and not for SPE.

In the event of dispute Rome's court of competent jurisdiction will apply.

The Purchaser declares his acceptance of the above Warranty Terms.

REPAIR FORM

MODEL SERIAL NUMBER DATE

CONNECTION STATUS AT THE MOMENT OF THE BREAKDOWN

TRANSCEIVER MODEL

CAT CONNECTION YES NO

IF YES INDICATE THE ITEM HEADING IN THE USER MANUAL

IF NO BAND DATA INTERFACE YES

ANY LINK? YES

WAS THE ALC CONNECTED? YES NO

WAS THE DRIVING POWER OF THE TRANSCEIVER SET AT THE MAXIMUM LEVEL? YES NO

IF 'NO', WHAT POWER OUTPUT WAS SET?

ON WHICH BAND DID THE FAULT HAPPEN?

DID YOU CHANGE BANDS / ANTENNA IMMEDIATELY BEFORE THE FAULT HAPPENED? YES NO

PLEASE WRITE THE TRANSMISSION MODE: SSB CW QSK DIGITAL MODE/FM AM

FOR HOW LONG BEFORE THE FAILURE DID YOU SWITCH ON THE AMPLIFIER?

THE AMPLIFIER WAS IN THE: LOW MID MAX

WHICH INPUT WAS USED? INPUT 1 INPUT 2

WHAT WAS THE TEMPERATURE OF THE AMPLIFIER ?

WHAT FAULT INFORMATION WAS DISPLAYED ON THE LCD?

WHAT WAS THE MAINS VOLTAGE AT THE MOMENT OF THE BREAKDOWN?

OTHER INFORMATION:
.....
.....
.....
.....
.....
.....
.....
.....
.....
.....

SPACE FOR THE REPAIRER

REPAIRER DATE OF ARRIVAL

NOTES ABOUT THE AMPLIFIER WHEN YOU RECEIVED IT
.....
.....
.....
.....
.....
.....
.....
.....
.....
.....

PARTS REPLACED

.....
.....
.....
.....
.....
.....
.....
.....
.....
.....
.....

DATE OF TESTS

SIGNATURE OF THE REPAIRER

.....

.....

SPE s.r.l.

Via di Monteverde, 33 00152 Rome (Italy)

Tel. +390658209429

Fax. +390658209647

E-mail: info@linear-amplifier.comWebsite: <http://www.linear-amplifier.com>